

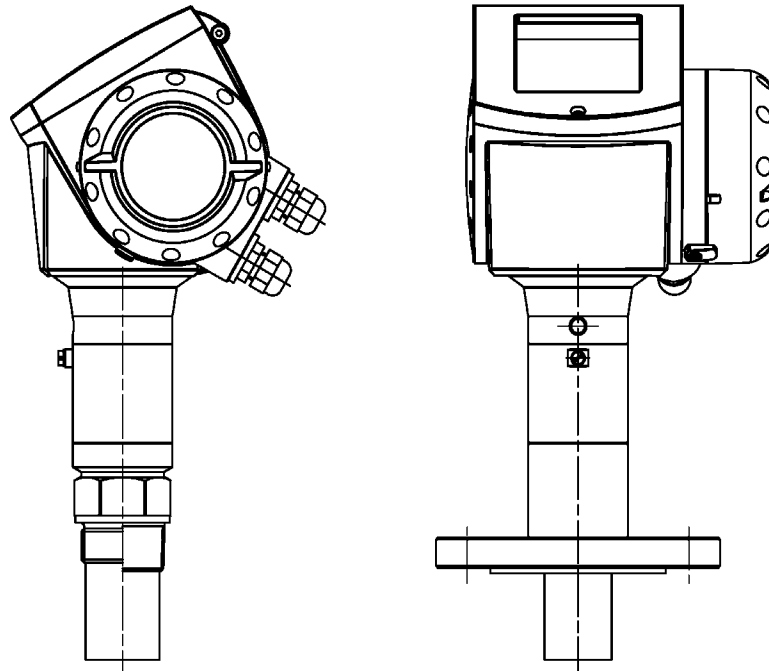

**ATEX Supplementary Installation & Operating Instructions  
KEMA 05 ATEX 1117 X**

**Reflex VG7 High Frequency FMCW Radar  
Type VG7**



**Hycontrol Limited, Larchwood House, Orchard Street, Redditch,  
Worcestershire, B98 7DP, England**  
Tel: + 00 44 (0)1527 406800 Fax: + 00 44 (0)1527 406810  
Email: [sales@hycontrol.com](mailto:sales@hycontrol.com) Website: [www.hycontrol.com](http://www.hycontrol.com)

---

---

## Contents

---

<b>General safety information</b> .....	<b>3</b>
<b>Device description</b> .....	<b>3</b>
<b>ATEX nameplates</b> .....	<b>3</b>
<b>Standards and approvals</b> .....	<b>4</b>
<b>1 Mechanical Installation</b> .....	<b>5</b>
1.1 Precautions .....	5
1.1.1 General notes.....	5
1.1.2 Electrostatic discharge .....	5
1.1.3 Special conditions for safe use.....	5
1.1.4 Optional flushing system .....	5
1.2 Operating conditions .....	6
<b>2 Electrical connection</b> .....	<b>7</b>
2.1 General notes.....	7
2.2 The terminal compartment cover.....	7
2.2.1 Opening the cover.....	7
2.2.2 Closing the cover .....	7
2.3 EEx i equipment.....	8
2.3.1 Wiring.....	8
2.3.2 Minimum supply voltage.....	8
2.4 EEx d [ia] equipment .....	9
2.4.1 Wiring.....	9
2.4.2 Minimum supply voltage.....	9
2.4.3 Power supply.....	10
<b>3 Commissioning</b> .....	<b>12</b>
<b>4 Service and maintenance</b> .....	<b>12</b>
Return a device for testing or repair to HYCONTROL.....	13
<b>Declaration of Conformity</b> .....	<b>14</b>
<b>EC-Type-Examination Certificate KEMA 05 ATEX1117 X</b> .....	<b>15</b>

---

## General safety information

---

This document only contains explosion protection information for ATEX applications. For all other data, use the Quick Start and Online Handbook for REFLEX VG7 radar level meters. If you do not have the installation and operating instructions, please contact the nearest HYCONTROL office or download them from HYCONTROL's website [www.hycontrol.com](http://www.hycontrol.com)



### Warning

Install, commission and service the device only if you are trained for explosion protection of installations.

---

## Device description

---

The REFLEX VG7 is a 2-wire level meter using FMCW (Frequency-Modulated Continuous Wave) radar technology. It is used for measuring level, volume, distance to surface, and reflectivity of liquids, pastes, slurries and solid particles, granulates and powders. It is suitable for installation on storage tanks, process tanks and stilling wells. Measurements are displayed via a DTM (device type manager) for remote communication or on an optional integrated display screen with wizard-driven setup and online help functions.

The REFLEX VG7 is approved for use in potentially explosive atmospheres when equipped with the appropriate options.

---

## ATEX nameplates

---

Information for ATEX applications is indicated below

### EEx ia nameplate

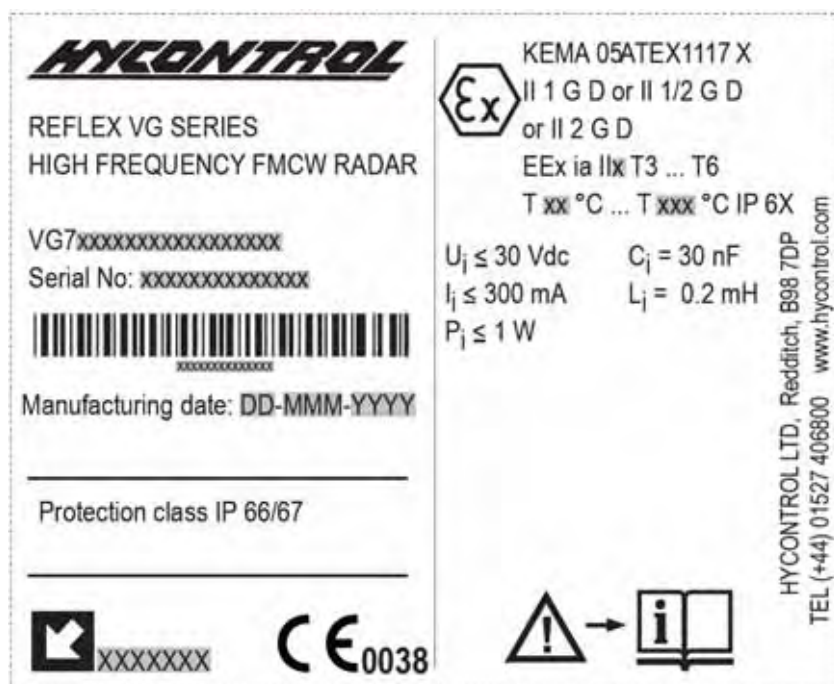

1. ATEX certification agency code. Refer to section 1.2 for all temperature information.
2. Equipment approval categories
3. Types of device protection including approved Gas Groups (IIA, IIB or IIC) and temperature classes for hazardous areas and maximum surface temperature (please refer to the certificate)
4. Intrinsically-safe circuit data

## EEx d nameplate

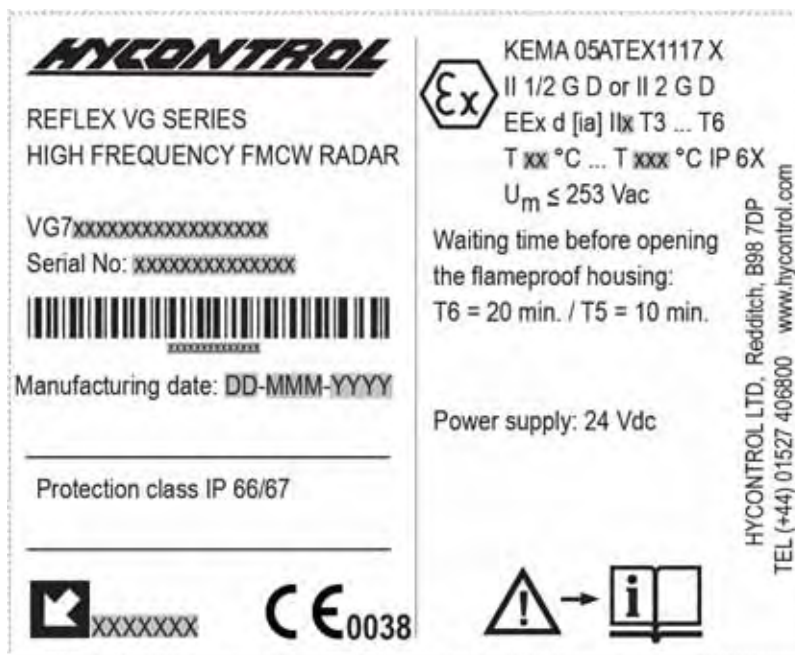

5. Maximum voltage in accordance with EN 50014 / IEC 60079-0
6. Minimum waiting time after power-off before it is safe to open the terminal compartment

## Standards and approvals



In compliance with European Directive 94/9/EC (ATEX 100a), the ATEX version of the level meter described in these Supplementary Instructions conforms to European Standards EN 50014 +A1 +A2, EN 50018 +A1, EN 50020, EN 50281-1-1 +A1, and EN 50284. It is certified for use in hazardous areas by the KEMA certification agency under KEMA 05ATEX1117X.



### Warning

Read the ATEX approval certificate for the Reflex VG7 carefully and observe boundary conditions given.

The Reflex VG7 radar level meter is suitable for use in potentially explosive atmospheres of all flammable substances in Gas Groups IIA, IIB and IIC and for applications requiring Category 1G (gases, vapours or mists), 1D (dust), 1/2G, 1/2D, 2G or 2D equipment when fitted with the appropriate options.

### Approved category definitions

#### Category 1

The meter is installed in hazardous areas requiring Category 1G or 1D equipment.

#### Category 1/2

The signal converter is installed in hazardous areas requiring Category 2G or 2D equipment. The antenna is installed in hazardous areas requiring Category 1G or 1D equipment.

#### Category 2

The meter is installed in hazardous areas requiring Category 2G or 2D equipment.

---

## 1 Mechanical Installation

---

### 1.1 Precautions

#### 1.1.1 General notes



When you install the device, observe

- the special conditions for safe use\*
- the Essential Health and Safety Requirements\*

\* Read the EC-Type Examination Certificate in the last section of this manual.

#### 1.1.2 Electrostatic discharge



##### **Warning: Danger of electrostatic discharge from the sun cover**

A plastic sun cover is supplied with the device on request. Take the necessary antistatic precautions when

- handling,
- installing, or
- using



the device in potentially explosive atmospheres. Check that all personnel and equipment are properly grounded. If the sun cover needs cleaning, wipe with a damp cloth.

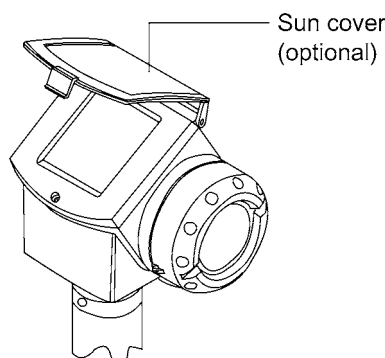

#### 1.1.3 Special conditions for safe use



##### **Warning: Installation of category 1G equipment**

When installing a VG7 with aluminium alloy enclosure (normally painted orange) in a potentially explosive atmosphere, position it so that even in the event of rare incidents, an ignition source due to impact or friction with iron/steel is avoided.

#### 1.1.4 Optional flushing system

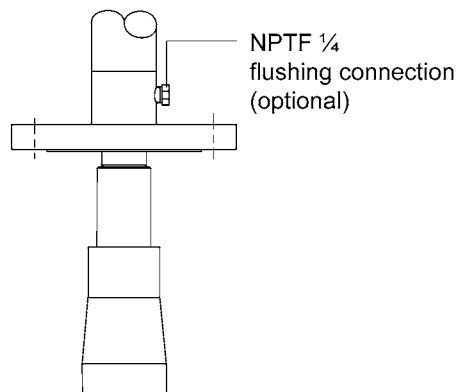

If delivered with the device, the flushing connection is closed off by a 1/4" screw. The NPTF plug is engaged on a minimum of five threads.

Connection and operation of the flushing connection fall within the responsibility of the operator. When this screw is removed, the operator is responsible for ensuring conformance with the 'Ex' requirements pertaining to the flushing system (e.g. fitting a flame trap).

The operator is also responsible for selection of a suitable flushing medium.

---

## 1.2 Operating conditions

The allowable ambient temperature and corresponding process temperature range for Reflex VG7 level meters depends on the ATEX equipment category and temperature classes marked on the nameplate.

### Ambient and process temperatures

#### Equipment category II 1 G (EEx i devices only)

Temperature class	Ambient temperature	Flange temperature
T6	-20°C ... +60°C	-20°C ... +60°C

#### Equipment category II 1/2 G

Temperature class	Ambient temperature	Flange temperature
T6	-40°C ... +60°C	-20°C ... +60°C
T5	-40°C ... +75°C	-20°C ... +60°C
T4	-40°C ... +85°C	-20°C ... +60°C

#### Equipment category II 2 G

Temperature class	Ambient temperature	Flange temperature
T6	-40°C ... +60°C	-40°C ... +60°C
	-40°C ... +55°C	-40°C ... +80°C
T5	-40°C ... +75°C	-40°C ... +75°C
	-40°C ... +70°C	-40°C ... +95°C
T4	-40°C ... +85°C	-40°C ... +85°C
	-40°C ... +80°C	-40°C ... +110°C
	-40°C ... +75°C	-40°C ... +135°C
T3	-40°C ... +70°C	-40°C ... +150°C
	-40°C ... +65°C	-40°C ... +180°C
	-40°C ... +60°C	-40°C ... +200°C

#### Equipment categories II 1 D (EEx i devices only), II 1/2 D and II 2 D

Ambient temperature	Flange temperature
-40°C ... +85°C	-40°C ... +200°C

#### Maximum surface temperature of electronics housing

##### Equipment categories II 1 D, II 1/2 D and II 2 D

Max. ambient temperature	Max. flange temperature	Max. surface temperature
55°C	80°C	65°C
70°C	95°C	80°C
75°C	135°C	86°C
60°C	200°C	90°C

#### Pressure

Equipment category	Allowable process pressure range
1G, 1D, 1/2G or 1/2D	Atmospheric pressure (80kPa...110kPa)
Others	As per non-EEx instrument

---

## 2 Electrical connection

---

### 2.1 General notes



**Read the information below carefully**  
**Disconnect power supply before wiring**

- Do not use the earth terminal in the wiring compartment: use the equipotential bonding system. See section 2.4.3.
- For ambient temperature  $>70^{\circ}\text{C}$ , use heat-resistant cables and cable glands certified for continuous operation above  $85^{\circ}\text{C}$

### 2.2 The terminal compartment cover

#### 2.2.1 Opening the cover

##### Procedure

1. Switch off power supply  
**EEx d applications:** Wait for the time given in the table below before opening

Temperature class	Time to wait after de-energizing the device
T6	20 minutes
T5	10 minutes
T4 and T3	Not necessary

2. Unscrew cover stop
3. Unscrew terminal compartment cover

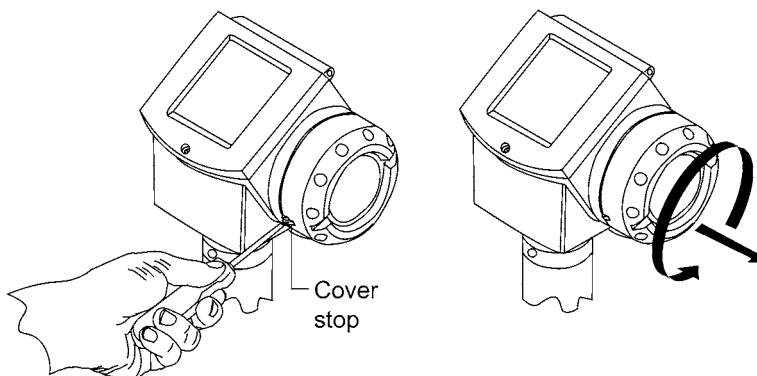

#### 2.2.2 Closing the cover

When putting the terminal compartment cover back on the housing, retighten the cover stop to make sure the cover stays firmly closed.

## 2.3 EEx i equipment

### 2.3.1 Wiring

1. Wire as for a standard device. Cable entries are supplied on customer demand; those supplied by the customer must have a degree of ingress protection IP6X according to EN60529. Supply the EEx i equipment connected to the device. Use certified intrinsically-safe equipment only.
2. Maximum intrinsically safe values:



$$\begin{aligned} U_i &\leq 30 \text{ V} \\ I_i &\leq 300 \text{ mA} \\ P_i &\leq 1 \text{ W} \end{aligned}$$

$$\begin{aligned} C_i &= 30 \text{ nF} \\ L_i &= 0.2 \text{ mH} \end{aligned}$$

### 2.3.2 Minimum supply voltage

The graph below shows the minimum supply voltage needed to operate the device with a loop current of 20.5 mA. For example, use a supply voltage of 14.5 Volts or more if the electrical circuit has a loop resistance of 200 ohms.

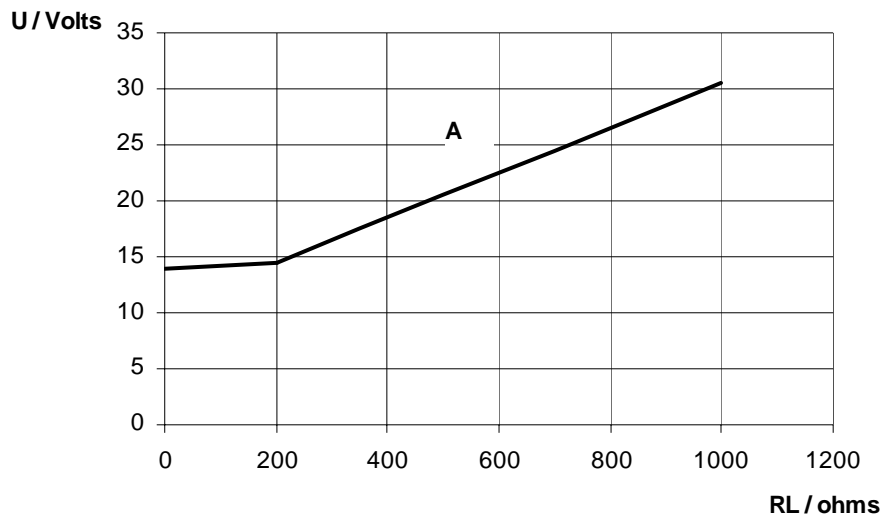

U = Supply voltage

RL = Loop resistance

A = Minimum supply voltage needed to operate the device at 20.5 mA

---

## 2.4 EEx d [ia] equipment

### 2.4.1 Wiring

1. Use only EEx d-approved cable entries and plugs: these are supplied on customer demand. Cable entries and plugs supplied by the customer must have a degree of ingress protection IP6X according to EN 60529.
2. If you only use one cable entry, seal the other one with an EEx d-approved plug.
3. Power supply needed for first output: 20 ... 36 volts.
4. Power supply needed for second output: 10 ... 30 volts.
5. All EEx d-approved installations must conform to European standards EN 50018 and EN IEC 60079-1.

#### Special note: conduit entries

1. Connect the device to an EEx d-approved conduit system.
2. Install a suitable EEx d-approved sealing device: for further information, please refer to European Standard EN 50018.
3. If you only use one cable entry, seal the other one with an EEx d-approved plug.

### 2.4.2 Minimum supply voltage

The graph below shows the minimum supply voltage needed to operate the device with a loop current of 20.5 mA. For example, use a supply voltage of 19 Volts or more if the electrical circuit has a loop resistance of 200 ohms.

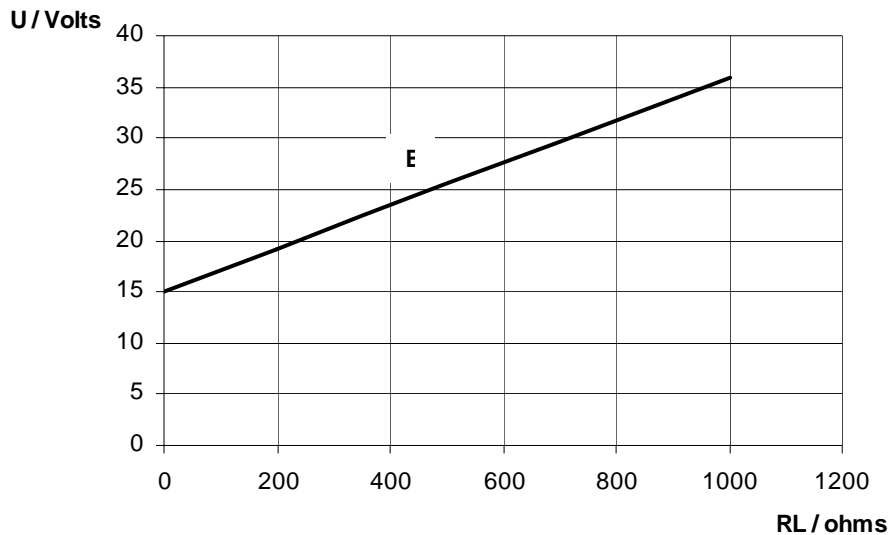

U = Supply voltage

RL = Loop resistance

B = Minimum supply voltage needed to operate the device at 20.5 mA

#### Special notes: load resistor

Connect the load resistor to the positive terminal of the power supply and ground the negative connection. Never ground the positive connection.

If the load resistor has to be connected to the negative terminal, do not exceed a loop resistance of 250 ohms.

### 2.4.3 Power supply

Make sure that the load resistor is connected to the +ve side. If the power supply is not galvanically isolated as in (1.), connect the ground of the power supply to the equipotential system (2.).

#### 1. With galvanic isolation

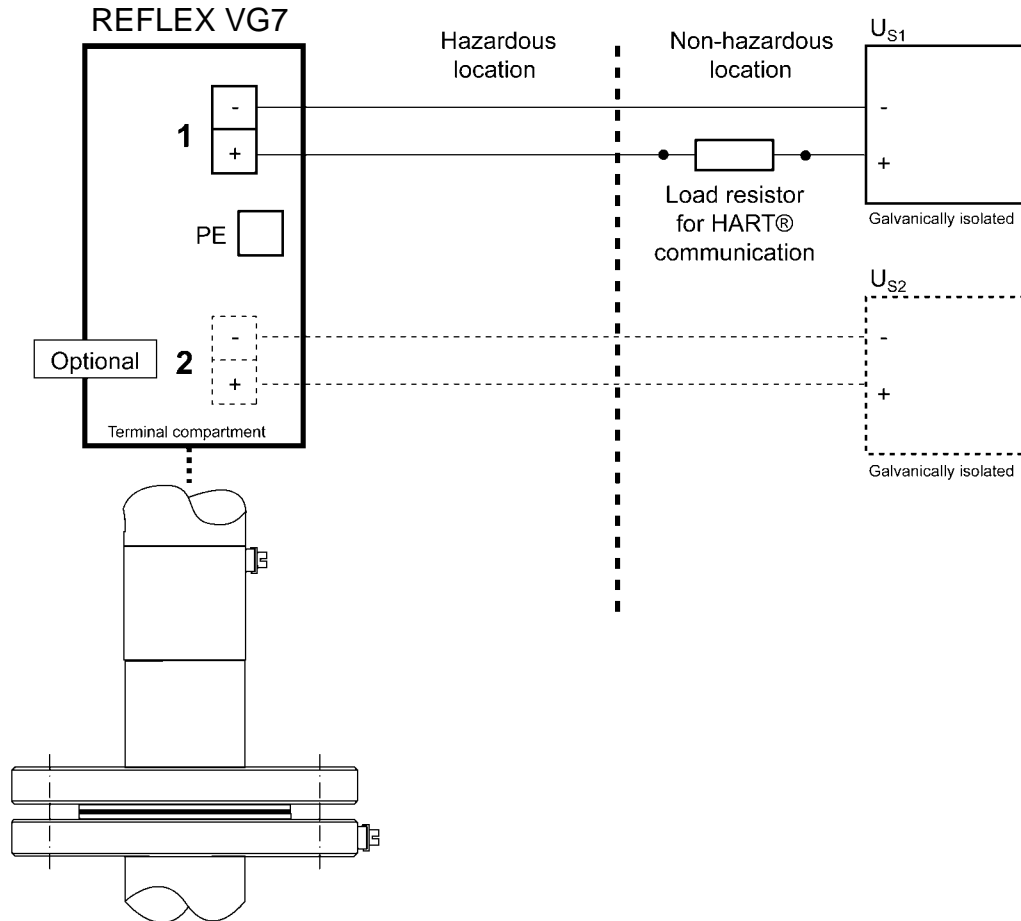

2. Without galvanic isolation

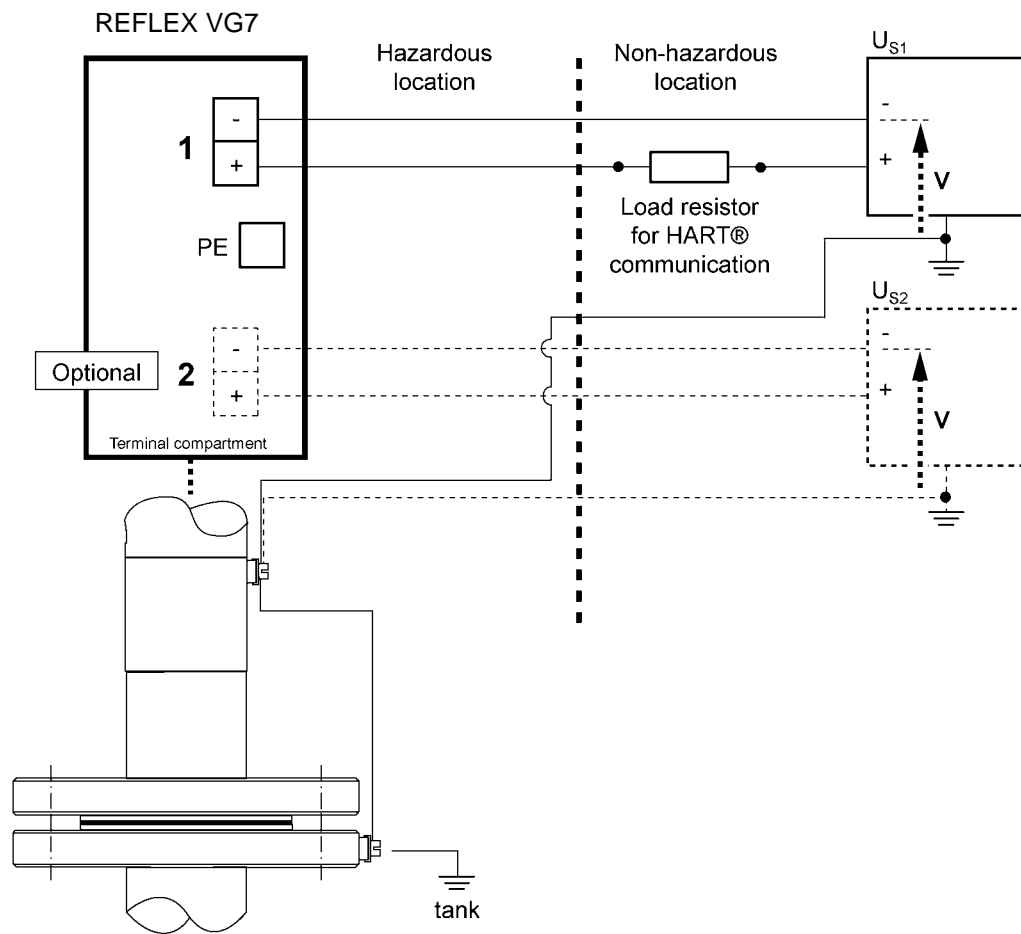

where  $|V| < 5V$

---

### 3 Commissioning

---

#### Start-up checklist



**Do not connect power until you have gone through the checklist below**

1. Are the wetted components (antenna, gasket, flange, and PTFE cone) resistant to the corrosive properties of the tank product?
2. Does the information given on the nameplate correspond with the application?
3. Have you connected the equipotential bonding system correctly?
4. EEx d applications: Are the cable entries, plugs and adaptors EEx d-approved?
5. EEx i applications: Are you using an intrinsic barrier within the correct parameters? Refer to section 2.3 for the maximum intrinsically safe values for the electrical circuit.
6. Did you install cable entries of the correct internal diameter so that there is a good seal around the cable?
7. Does the flushing system conform to 'Ex' requirements?

---

### 4 Service and maintenance

---



Maintenance in hazardous areas can only be carried out by

- the manufacturer
- a HYCONTROL-authorized representative
- technicians under the supervision of authorized inspectors

NOTE: Refer to page 13 for Returns Certification

---

---

**Return a device for testing or repair to HYCONTROL**

---

This device has been carefully manufactured and tested. If installed and operated in accordance with these operating instructions, it will rarely present any problems. Should you nevertheless need to return a device for inspection or repair, please pay strict attention to the following points:

Due to statutory regulations on environmental protection and safeguarding the health and safety of our personnel, HYCONTROL may only handle, test and repair returned devices that have been in contact with products without risk to personnel and environment.

This means that HYCONTROL can only service this device if it is accompanied by the following certificate confirming that the device is safe to handle.

If the device has been operated with toxic, caustic, flammable or water-endangering products, you are kindly requested:

to check and ensure, if necessary by rinsing or neutralizing, that all cavities are free from such dangerous substances, to enclose a certificate with the device confirming that is safe to handle and stating the product used.

We cannot service this device unless accompanied by such a certificate.

<b>SPECIMEN certificate</b>
-----------------------------

Company: ..... Address: .....

Department: ..... Name: .....

Tel. No.: ..... Fax No.: .....

The enclosed device

Type: .....

HYCONTROL Order No. or Series No.:  
.....

has been operated with the following liquid: .....

Because this liquid is       water-hazardous       toxic       caustic       flammable

we have       checked that all cavities in the instrument are free from such substances /

flushed out and neutralized all cavities in the device

We confirm that there is no risk to humans or environment through any residual liquid contained in this device.

Date: ..... Signature: .....

Company stamp:

---

---

## Declaration of Conformity

---

We: HYCONTROL LIMITED  
Larchwood House, Orchard Street,  
Redditch, Worcestershire, B98 7DP, United Kingdom

Declare under our sole responsibility that the product:

**Level Measuring Instrument  
Reflex VG7**

to which this declaration relates, is in conformity with the following standards or other normative documents:

Low tension	EN61010-1 : 2001
EMC	EN61326 : 1997 (Class B*)
	EN61326 : 1997/A1 : 1998 / A2 : 2001
ATEX	* in enclosed metallic tanks
	EN50014 : 1997 + A1 + A2
	EN50018 : 2000 + A1
	EN50020 : 2002
	EN50284 : 1999
	EN50281-1-1 : 1998 + A1

According to the provisions of Directive 89/336/EEC (Electromagnetic Compatibility),  
73/23/EEC (Low Voltage Directive) and 94/9/EC (ATEX).

Notified body:  
KEMA Quality BV (0344)  
Utrechtseweg 310, 6802 ED Arnhem  
The Netherlands

EC-Type Examination Certificate: **KEMA 05 ATEX 1117 X**

Quality Assurance System monitored by:

LRQA (0038)  
Hiramford  
Coventry  
Warwickshire, CV3 4JF

Certificate No: 0961118/B

Signed:



**B C Allen**  
**Managing Director**

Date: August 2005



(1) **EC-TYPE EXAMINATION CERTIFICATE**

(2) **Equipment and protective systems intended for use in potentially explosive atmospheres - Directive 94/9/EC**

(3) EC-Type Examination Certificate Number: **KEMA 05ATEX1117 X** Issue Number: **3**

(4) Equipment: **Reflex VG Series High Frequency FMCW Radar Type VG7 .....**

(5) Manufacturer: **Hycontrol Ltd.**

(6) Address: **Larchwood House, Orchard Street, Redditch, Worcestershire, B98 7DP, United Kingdom**

(7) This equipment and any acceptable variation thereto is specified in the schedule to this certificate and the documents therein referred to.

(8) KEMA Quality B.V., notified body number 0344 in accordance with Article 9 of the Council Directive 94/9/EC of 23 March 1994, certifies that this equipment has been found to comply with the Essential Health and Safety Requirements relating to the design and construction of equipment and protective systems intended for use in potentially explosive atmospheres given in Annex II to the directive.

The examination and test results are recorded in confidential test report number 2108504/2.

(9) Compliance with the Essential Health and Safety Requirements has been assured by compliance with:

**EN 50014 : 1997 + A1, A2**  
**EN 50281-1-1 : 1998 + A1**

**EN 50018 : 2000 + A1**  
**EN 50284 : 1999**

**EN 50020 : 2002**

(10) If the sign "X" is placed after the certificate number, it indicates that the equipment is subject to special conditions for safe use specified in the schedule to this certificate.

(11) This EC-Type Examination Certificate relates only to the design, examination and tests of the specified equipment according to the Directive 94/9/EC. Further requirements of the directive apply to the manufacturing process and supply of this equipment. These are not covered by this certificate.

(12) The marking of the equipment shall include the following:



**II 1 G D or II 1/2 G D or II 2 G D**  
**EEx ia IIC or EEx ia IIB or EEx ia IIA T6 ... T3 T 65 °C ... T 90 °C IP 6X**  
or  
**II 1/2 G D or II 2 G D**  
**EEx d[ia] IIC or EEx d[ia] IIB or EEx d[ia] IIA T6 ... T3**  
**T 65 °C ... T 90 °C IP 6X**

This certificate is issued on 26 July 2007 and, as far as applicable, shall be revised before the date of cessation of presumption of conformity of (one of) the standards mentioned above as communicated in the Official Journal of the European Union.

KEMA Quality B.V.

C.G. van Es  
Certification Manager



© Integral publication of this certificate and adjoining reports is allowed. This Certificate may only be reproduced in its entirety and without any change.



(13) **SCHEDULE**

(14) **to EC-Type Examination Certificate KEMA 05ATEX1117 X** Issue No. 3

(15) **Description**

The Reflex VG Series High Frequency FMCW Radar Type VG7 ..... is used for continuous level measurement of flammable or non-flammable liquids or solid particles, granulates or powders within storage or process tanks or in a stilling well.

The distance between the antenna and the surface of the process medium is measured using a frequency modulated continuous wave radar.

The 2-wire transmitter is loop powered. The output signal is a 4 - 20 mA current signal with digital communication (HART protocol).

Either the Reflex VG Series High Frequency FMCW Radar is completely in type of protection intrinsic safety "i" or the transmitter is provided with the power supply compartment in type of protection flameproof enclosure "d". In the latter version a zener barrier circuit board is integrated in the power supply module.

Optionally, the transmitter may be provided with a second 4 - 20 mA current output and with display and adjustment capabilities (HMI option).

The ambient temperature range and the flange temperature range, depending on the equipment category required in the area where the transmitter is installed, are as listed in the following table:

Equipment category	Ambient temperature range	Flange temperature range
II 1 G	-20 °C ... +60 °C	-20 °C ... +60 °C
II 1/2 G	-40 °C ... +85 °C	-20 °C ... +60 °C
II 2 G	-40 °C ... +85 °C	-40 °C ... +200 °C
II 1 D, II 1/2 D, II 2 D	-40 °C ... +85 °C	-40 °C ... +200 °C

The temperature class depending on the ambient temperature and the flange temperature is for the different versions as listed in following table:

Equipment category	Max. ambient temperature	Max. flange temperature	Temperature class
II 1 G	60 °C	60 °C	T6
II 1/2 G	60 °C	60 °C	T6
	75 °C	60 °C	T5
	85 °C	60 °C	T4
II 2 G	60 °C	60 °C	T6
	55 °C	80 °C	T5
	75 °C	75 °C	
	70 °C	95 °C	
	85 °C	85 °C	T4
	80 °C	110 °C	
	75 °C	135 °C	
	70 °C	150 °C	
65 °C	180 °C	T3	
60 °C	200 °C		



(13) **SCHEDULE**

(14) **to EC-Type Examination Certificate KEMA 05ATEX1117 X** Issue No. 3

The maximum surface temperature of the electronics enclosure "T", depending on the ambient temperature and the flange temperature, is as listed in following table:

Max. ambient temperature	Max. flange temperature	Surface temperature "T"
55 °C	80 °C	65 °C
70 °C	95 °C	80 °C
75 °C	135 °C	86 °C
60 °C	200 °C	90 °C

The enclosure provides a degree of protection of at least IP6X as per EN 60529.

**Electrical data**

Apparatus in type of protection intrinsic safety "i"

Supply and output circuit (terminals output 1, + and -):  
in type of protection intrinsic safety EEx ia IIC, only for connection to a certified intrinsically safe circuit, with the following maximum values:

$U_i = 30 \text{ V}$ ;  $I_i = 300 \text{ mA}$ ;  $P_i = 1 \text{ W}$ ;  $C_i = 30 \text{ nF}$ ;  $L_i = 200 \text{ }\mu\text{H}$ .

Output circuit (terminals output 2, + and -):  
in type of protection intrinsic safety EEx ia IIC, only for connection to a certified intrinsically safe circuit, with the following maximum values:

$U_i = 30 \text{ V}$ ;  $I_i = 300 \text{ mA}$ ;  $P_i = 1 \text{ W}$ ;  $C_i = 30 \text{ nF}$ ;  $L_i = 200 \text{ }\mu\text{H}$ ,

The optional second current output circuit is infallibly galvanically isolated from the supply and output circuit and from the earthed parts of the transmitter.

Apparatus in type of protection flameproof enclosure "d"

Power supply ..... max. 36 Vdc  
Output ..... 4 - 20 mA  
Intrinsically safe circuits .....  $U_m = 253 \text{ V}$

**Installation instructions**

Apparatus in type of protection intrinsic safety "i"

When the Reflex VG Series High Frequency FMCW Radar is used in explosive atmospheres caused by air/dust mixtures, cable entry devices shall be used that provide a degree of protection of at least IP 6X, that are suitable for the application and are correctly installed.



(13) **SCHEDULE**

(14) **to EC-Type Examination Certificate KEMA 05ATEX1117 X** Issue No. 3

Apparatus in type of protection flameproof enclosure "d"

When used in a potentially explosive atmosphere, requiring the use of apparatus of equipment category 2G, flameproof certified cable entry devices shall be used that are suitable for the application and correctly installed. With the use of conduit, a suitable certified sealing device such as a stopping box with setting compound shall be provided immediately at the entrance to the flameproof enclosure.

When used in a potentially explosive atmosphere, requiring the use of apparatus of equipment category 2D, certified cable entry devices shall be used that provide a degree of protection of at least IP 6X, that are suitable for the application and are correctly installed.

Unused openings shall be closed with suitable certified blanking elements.

When the ambient temperature exceeds 70 °C, the cables, cable entry devices and blanking elements shall be suitable for at least 85 °C.

**Routine tests**

Routine tests according to Clause 16 of EN 50018 are not required since the type test has been made at a static pressure of four times the reference pressure.

(16) **Test Report**

KEMA No. 2108504/2

(17) **Special conditions for safe use**

For the versions of the Reflex VG Series High Frequency FMCW Radar with an enclosure made of aluminium alloy, when used in a potentially explosive atmosphere requiring the use of apparatus of equipment category 1 G, the apparatus must be installed so, that even in the event of rare incidents, an ignition source due to impact or friction between the enclosure and iron/steel is excluded.

Also, see description and installation instructions above.

(18) **Essential Health and Safety Requirements**

Covered by the standards listed at (9).  
Standards EN 61241-0 and IEC 61241-11 have been used as a guide.

(19) **Test documentation**

As listed in Test Report No. 2108504/2