

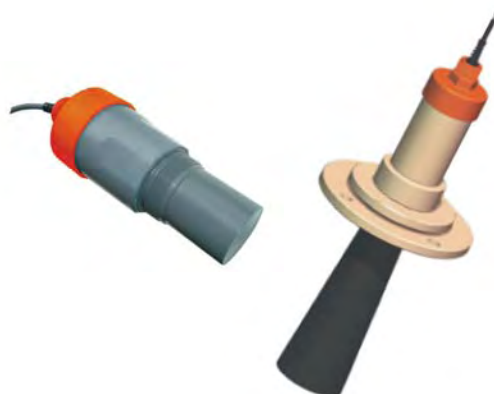

## **Microflex LR – Smart Transmitter** (Ultrasonic Level Measurement)

# **Installation & Operation Instruction Manual**



Hycontrol Limited, Larchwood House, Orchard Street,  
Redditch, Worcestershire, UK. B98 7DP  
Tel: + 00 44 (0)1527 406800 Fax: +00 44(0)1527 406810  
Email: [sales@hycontrol.com](mailto:sales@hycontrol.com) Web: [www.hycontrol.com](http://www.hycontrol.com)

## INDEX

	<u>PAGE</u>
<b>1. GENERAL DESCRIPTION</b>	<b>3</b>
1.1. Microflex LR - Smart Transmitter	4
<b>2. INSTALLATION GUIDE</b>	<b>5</b>
2.1. Installation Position	5
2.2. Installation Dimensions	6
2.3. Installation Wiring	7
2.3.1. Wiring Colour Code for MSA	7
2.3.2. Wiring Colour Code for MSB	7
2.3.3. Wiring Colour Code for MSC	7
2.3.4. Wiring Colour Code for MSD	7
2.4. Wiring Diagrams	8
2.4.1. MSA	8
2.4.2. MSB	8
2.4.3. MSC & MSD	8
2.4.4. Multi-Drop Applications	9
2.5. Hycontrol Link Wiring for Remote diagnostics via GSM	9
<b>3. PROGRAMMING</b>	<b>10</b>
3.1. Installing the Program	10
3.2. Running the Program	10
3.3. Setting the Communication Parameters	11
3.4. Entering Basic Data – QUICKSET	12
<b>4. GENERAL SPECIFICATION</b>	<b>14</b>
<b>5. PART NUMBER SELECTION</b>	<b>15</b>
<b>6. LABELLING AND INFORMATION</b>	<b>16</b>
<b>7. MODBUS REGISTER LIST</b>	<b>17</b>
<b>8. ASSEMBLY OF FLANGE AND CONES</b>	<b>21</b>

## **INSTRUCTION MANUAL**

### **MICROFLEX LR - SMART TRANSMITTER**

#### **1. GENERAL DESCRIPTION**

The Microflex LR – Smart Transmitter is capable of non-contact level measurement over distances of up to 60 metres, depending on the application. The transmitter is an intelligent, minimal system approach to measurement of solids and liquids with maximum performance but without costly display and keypad options.

The transmitter is available with four different transducers for ranges of 10, 20, 40 and 60 metre operation. Each configuration is available as a 2-wire, 4-20mA output transmitter with PC comms or it can have a combination of Modbus, relay, 4-20mA and PC comms output.

The transmitter must be mounted directly above the surface of the material to be monitored.

Ultrasonic pulses are transmitted to the surface of the material to be monitored and reflected back to the transmitter. The time period between transmission and reception of the pulses is directly proportional to the distance between the transmitter and the material.

Since the speed of sound through air is affected by temperature, a temperature sensor is integrated into the face of the transmitter to improve accuracy.

The Smart Transmitter is suitable for measuring the following on solids and liquids:

- a) Ullage space or distance to material
- b) Material level
- c) Volume measurement
- d) Material %

#### **WARNING**

**Do not remove any connection whilst the power is ON.**

**REFER TO 'ATEX Safety & Operating Instructions Manual'  
IF INSTALLING IN A HAZARDOUS AREA**

## 1.1 Microflex LR - Smart Transmitter

The Smart Transmitter is an easy-to-use level transmitter available with four (4) different high power, low frequency front ends, capable of reliably tracking the level of solids and liquids under difficult conditions.

Remote programming of the product is available via Hycontrol's Vision System II software and all the instruments can be connected via the Hycontrol Link to a Service Engineer in the Redditch office to analyse and overcome any problems which may be experienced in the field, without incurring any expensive call-out charges.

If specified, the instruments are available approved for ATEX EExm Zone 1 gases & Zone 21 dusts, or ATEX dust protection only, Zone 20.

The Microflex LR - Smart Transmitter is available with 4 different outputs:

- MSA with 2-wire loop powered, 4-20mA output & PC Comms  
- 4 core & Shield
- MSB with 4-20mA output, 1 Relay & PC Comms  
- 8 Core
- MSC with Modbus output and 1 Relay  
- 6 Core
- MSD with Modbus output and PC Comms  
- 4 Core

Focaliser cones are used with the longer range 20-60 metre transducers in order to improve signal strength and to ensure continuous tracking of material level under dusty conditions.



## 2. INSTALLATION GUIDE

The Smart Transmitter is designed to be screwed directly into a flange on a tank. For long range and dusty applications, the use of a focaliser on the underside of the flange improves the concentration of the signal and ensures that spurious signals are eliminated.

### 2.1 Installation Position

Ensure that the mounting surface is not subject to vibration and is not in close proximity to high voltage power cables, contactors or drive controls. The unit should not be mounted in a confined space where temperature may exceed the safe working temperature  $-20^{\circ}\text{C}$  to  $+80^{\circ}\text{C}^*$ . If the unit is mounted outside it should be protected from direct sunlight or severe weather conditions.

When using a focaliser cone, ensure that it protrudes at least 50mm into the vessel.

The transmitter should be installed to ensure a clear line-of-sight from the transducer face to the product being monitored. Refer to diagrams on Page 6.

Avoid mounting near fill points, ladders, baffles and agitators etc.

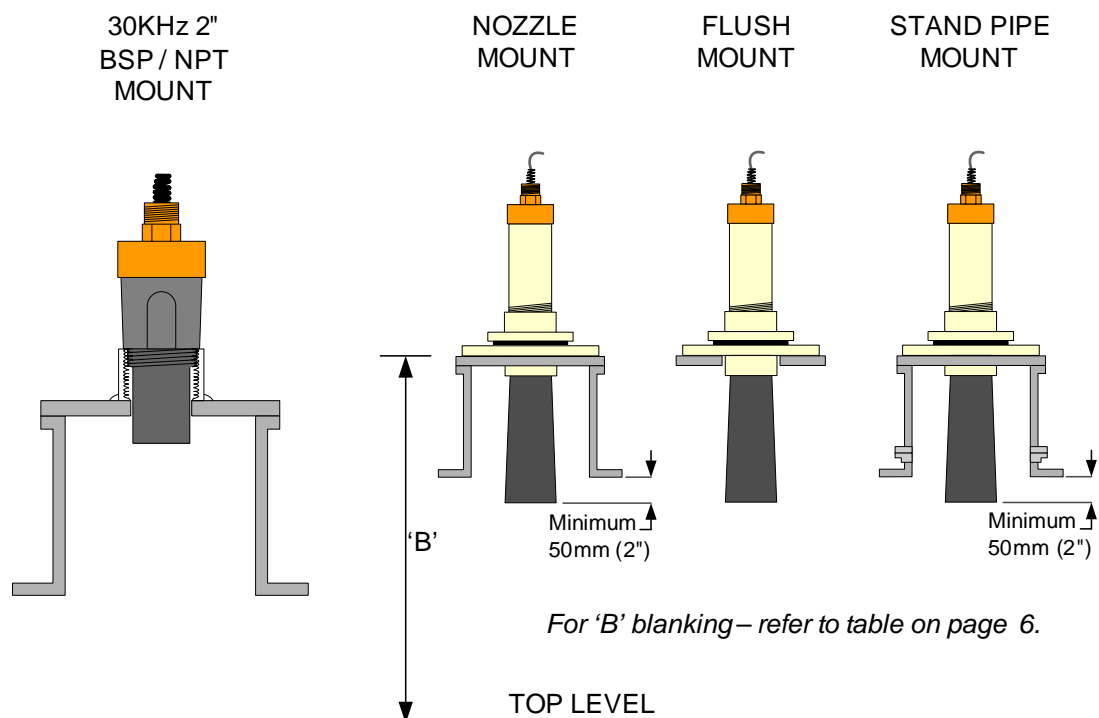

\*For ATEX temperature classifications see ATEX Safety & Operating Instructions Manual.

## Smart Transmitter Mounting

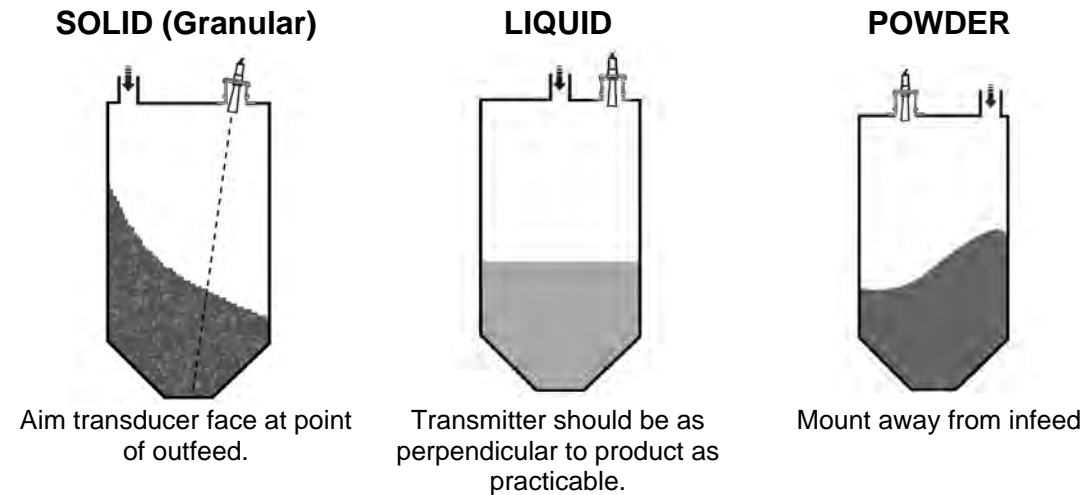

## 2.2 Installation Dimensions

MSA, B, C and D have common dimensions and only vary in size depending on range and the use of a focaliser.

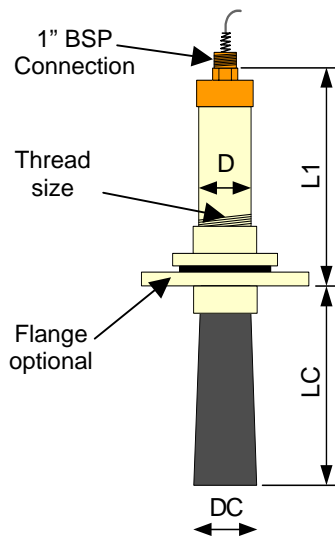

Range Metres	LI	LC Optional	D	DC Optional	Thread Size	Flange Optional
10	200	-	50	-	2"	-
20	280	275	75	98	3"	4"
40	436	413	89	236	3.5"	10"
60	719	460	89	236	-	10"

Flange Options: ANSI, DIN or JIS

Dimensions for 10, 20, 40 & 60 metre range

Ensure the distance between the transducer face and the highest expected product level in the tank is always greater than the Blanking Distance value.

TRANSMITTER	BLANKING DISTANCE	
	Minimum	Default
MS__10	0.35m (1.2ft)	0.5m (1.6ft)
MS__20	0.5m (1.6ft)	0.8m (2.6 ft)
MS__40	1.0m (3.3ft)	1.3m (4.2 ft)
MS__60	1.2m (4ft)	1.5m (5 ft)

## 2.3 Installation Wiring

The following specifies the wiring colour codes for the integral cable (6m standard).

### 2.3.1 Wiring Colour Code for MSA

2-wire, loop powered, 4-20mA output with PC Comms for programming  
- 4 core & Shield

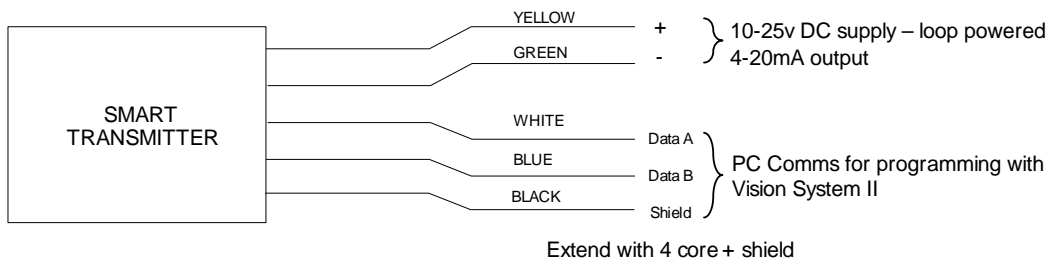

### 2.3.2 Wiring Colour Code for MSB

4-20mA output, 1 relay and PC Comms for programming – 8 core & Shield

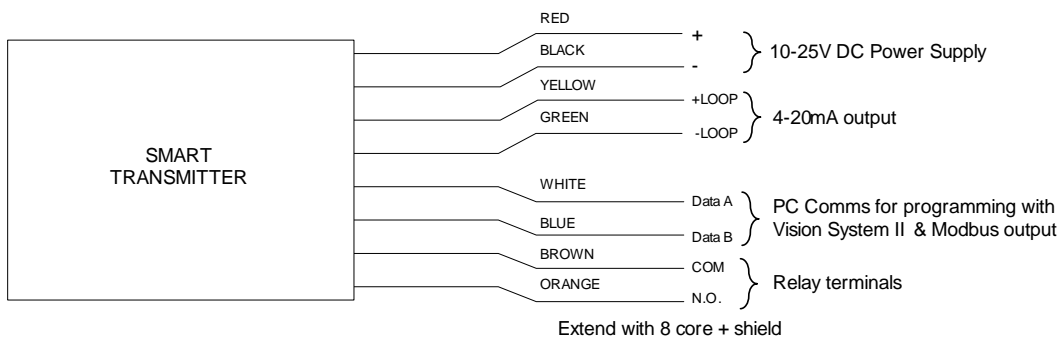

### 2.3.3 Wiring Colour Code for MSC

Modbus output plus 1 relay – 6 core & Shield

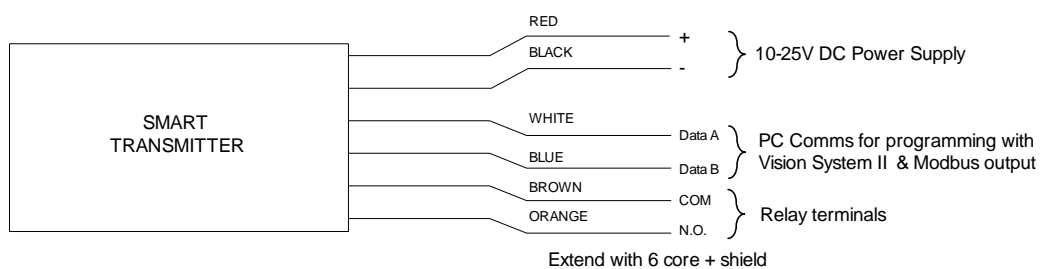

### 2.3.4 Wiring Colour Code for MSD

Modbus & PC Comms – 4 core & Shield

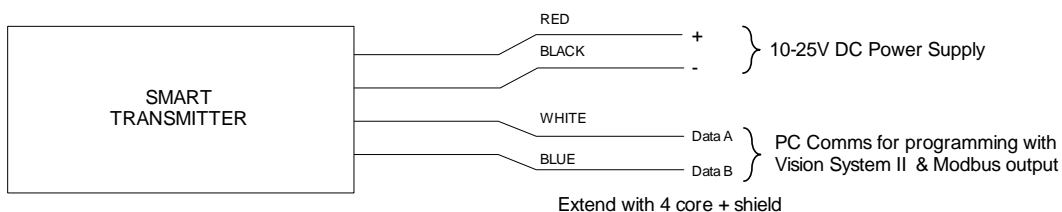

### 2.4.1 MSA 2 wire DC Loop Powered

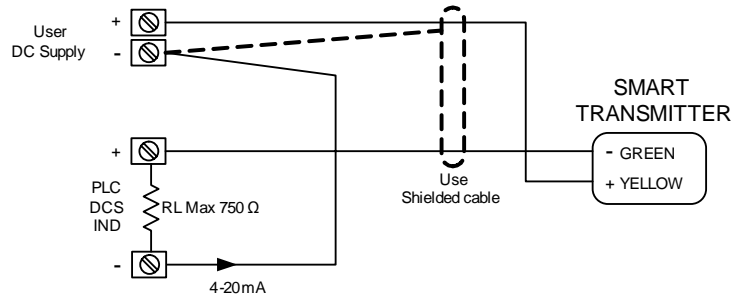

### 2.4.2 MSB 3 wire DC - Modulating from Common User Supply (RL to +DC)

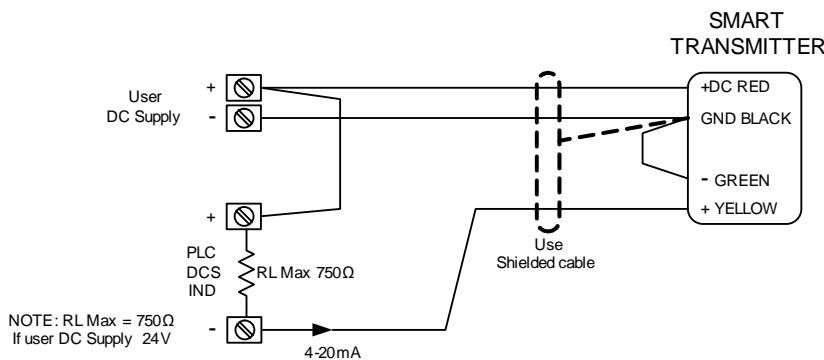

### MSB 3 Wire DC – Modulating from Common User Supply (RL to GND)

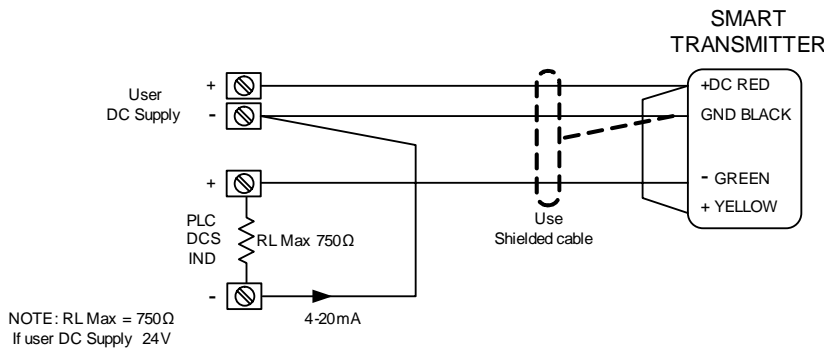

### 2.4.3 MSC, MSD

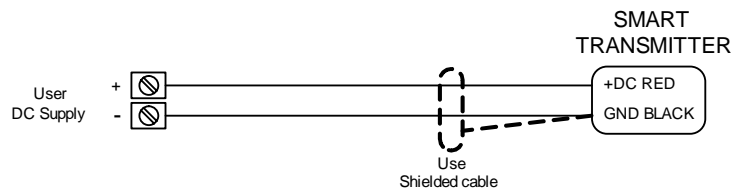

## 2.4.4 Multi-Drop Network (MODBUS) Connection

Connecting multiple Smart Transmitters with minimum wiring required.

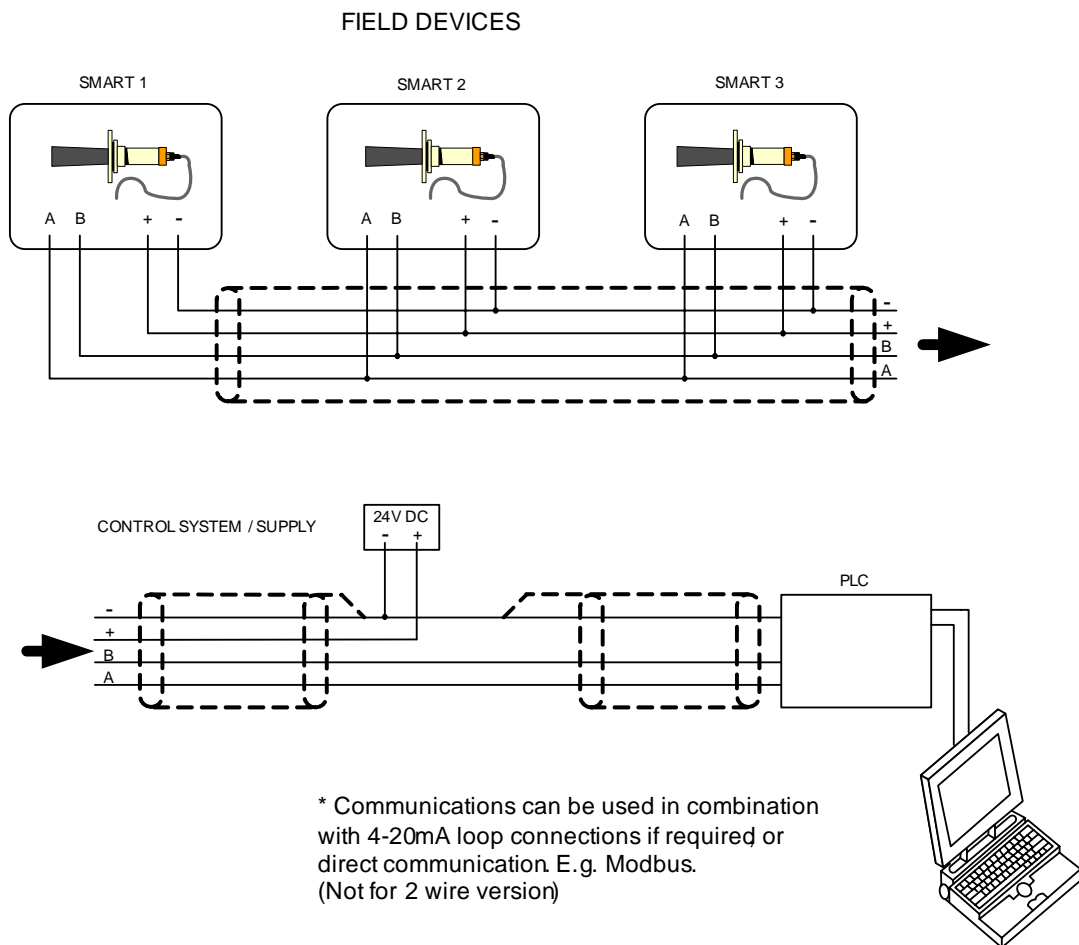

## 2.5 Hycontrol Link GSM Connection

The Hycontrol Link is a separately powered GSM module which enables Hycontrol Service Engineers to interrogate and program any Microflex LR Smart instrument.

The following diagram shows how to wire the Hycontrol Link to the Smart Transmitter.

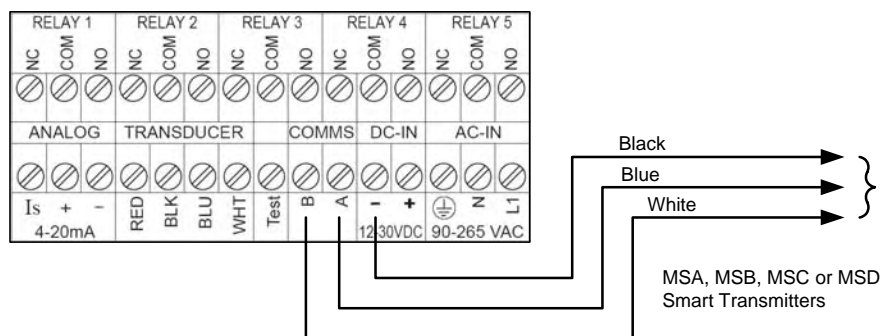

### 3. PROGRAMMING – Via Vision System II Software

Vision System II is a very powerful diagnostic tool that also allows the user to program the Smart Transmitter.

#### 3.1 Installing the Program

There are three ways a connection can be made between the PC and the RS485 bus.

- Direct connection to a PC com port via a USB-RS485 converter, a RS232 to RS485 converter or a PCMCIA RS485 adaptor.
- A wireless connection via a GSM modem.
- A TCP/IP connection via the internet.

Place the Vision System II CD in the drive, access it from 'My Computer' or 'Windows Explorer' and double-click on 'Set-up.exe'. The program will be installed in C:\Program Files\Hycontrol\VisionSystemII.

#### 3.2 Running the Program

From the Desktop, click 'Start' 'All Programs' 'Hycontrol' 'VisionSystemII' or navigate to C:\Program Files\Hycontrol\VisionSystemII and double-click on 'VisionSystemII.exe.'

In future, it may be convenient to create a short-cut to this file.

The program will come up displaying a box at the top of the screen as shown below:



- 1** Enables you to connect or disconnect from the instrument.
- 2** Select Device ID. New units are 01. Only change this if the instrument is being used in a multiple application.
- 3** Entering Basic Data - See Page 12.
- 9** To view product properties and set communication parameters.

### 3.3 Setting the Communication Parameters

Click 'View' ( 9 on page 10) on top of the tool bar. Click 'Options' on the drop down menu. The following 'Properties' screen comes up.

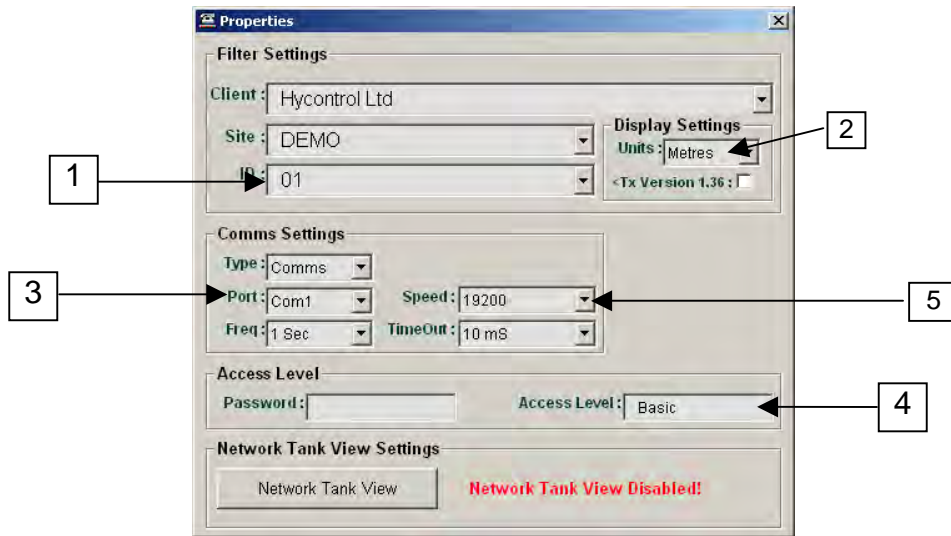

- 1 Set this field to the ID of the unit you wish to talk to. 01 is the default for single point instruments
- 2 Usually easier to program in metres and then change to feet if required.
- 3 Enter the number for the port that your RS485 comms is using. Make sure that this is correct as the instrument will not connect otherwise.
- 4 Select Basic
- 5 Set speed to 19200  
Click on the X in the top right corner to close the Properties screen.

Click the 'Connect' button ( 1 on page 10 ) to establish communication. The button icon changes to a hung-up telephone and is now used to disable communication and it shows an 'Info' screen.

Click the 'Set-up' button ( 3 on page 10 ) to bring up the 'Quick Start Menu' screen.

### 3.4 Entering Basic Data - QUICKSET

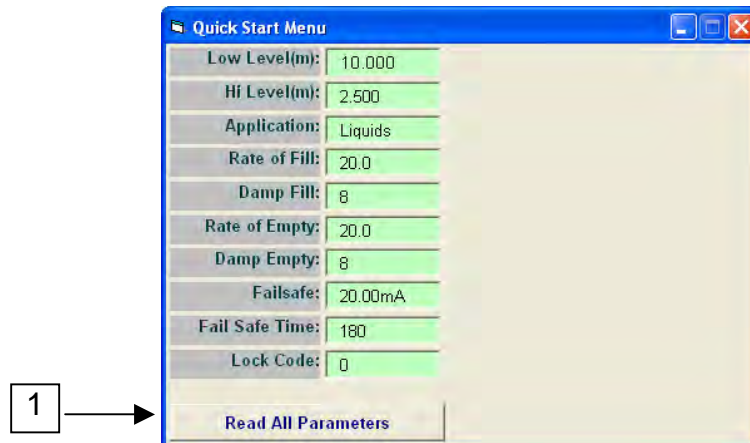

#### Changing Parameters

Click on any parameter field to alter it. The data may now be altered. Leaving the field by 'enter' or 'tab' will cause the data to be written to the device and read back. If the new value was successfully written and read back, that field will stay green.

A value outside normal limits will not be accepted and the field will return to the last entry, displaying "Error in writing data message" (with the required range) that needs to be input.

- Low Level - Enter the distance from the transducer face that corresponds to the low level in the vessel – 4mA output level.
- Hi Level - Enter the distance from the transducer face that corresponds to the high level in the vessel – 20mA output level.
- Application - Select from Slurries, Liquids or Solids.
- Rate of Fill - Rate of change of level during filling – units/hour.
- Damp fill - Damping during filling – 000 to 999 – low number, fast response.
- Rate of Empty - Rate of change of level during emptying – units/hour.
- Damp Empty - Damping during emptying – low number, fast response
- Failsafe - Select required mA output in failure mode.
- Failsafe time - Select time in seconds before failure is indicated.

To check that all new parameters have been accepted click the 'Read All Parameters' button  on Page 12 and check that all data displayed is correct.

Other screens available are:

- Info
- Quick Start
- Output adjust
- Tx Setup
- Tracking
- Factory
- ID Search
- Volume

but these should not need to be changed for most applications and need only be adjusted after consultation with Hycontrol.

## 4. GENERAL SPECIFICATION

<b>Instrument Type</b>	: <b>Microflex LR Smart Transmitter</b> : MSA - with 2 wire loop powered, 4-20mA & PC Comms - 4 core + Shield : MSB - with 4-20mA output, 1 Relay & PC comms - 8 core + Shield : MSC - with Modbus output and 1 Relay - 6 core + Shield : MSD - with Modbus output and PC Comms - 4 core + Shield
<b>Range</b>	: Up to 60 metres
<b>Blanking</b>	: Variable from 0.3 metres
<b>Process media</b>	: Liquids or Solids
<b>Analogue Output</b>	: 4-20mA into 750 Ohm Ext. Supply.
<b>Power Supply</b>	: 10 - 25V DC
<b>Relays</b>	: 1 Form C SPDT rated 0.5 amp at 240V AC
<b>Resolution</b>	: 1mm up to 20 metre range : 4mm from 20-60 metre range
<b>Accuracy</b>	: +/- 0.25% of maximum range
<b>Operating temperature</b>	: -40°C to + 80°C *
<b>Ambient temperature</b>	: Electronics -40°C to +80°C *
<b>Enclosure</b>	: Integral System IP67
<b>Mounting</b>	: MS__10 2" NPT or BSPT MS__20 4" Flanged ANSI, DIN or JIS MS__40/60 10" Flanged ANSI, DIN or JIS
<b>Weight</b>	: 2kg - 15kg depending on model
<b>Cable Extension</b>	: Belden 3084A up to 500 metres
<b>Comms options</b>	: Modbus : Multi-drop capability (up to 32 units) : Vision System II : Hycontrol GSM Link

\*For ATEX models refer to ATEX Safety & Operating Instructions manual.

## 5. PART NUMBER SELECTION:- MICROFLEX LR SMART TRANSMITTER

MODEL	Microflex LR Smart Transmitters	
MSA	With 2 wire loop powered, 4/20mA output & PC comms. 4 core+shld	
MSB	With 4/20mA output, 1 relay, and PCcomms. 8 core+shld	
MSC	With Modbus and 1 Relay. 6core+ shld	
MSD	With Modbus only. 4 core+shld	
<b>Power Supply</b>		
A	10-25V DC	
<b>Measuring Range - Transducer Frequency</b>		
10	30KHz 10m max	
20	20KHz 20m max	
40	10KHz 40m max	
60	5KHz 60m max	
<b>Process Temperature - Transducer Facing Material</b>		
S	Standard Temperature ~ Dry Product ~ 10 & 5KHz Polyolefin	
T	Standard temperature ~ Wet atmosphere ~ Teflon face, 30 and 20KHz	
<b>Transducer Housing Material</b>		
4	Polypropylene - 20, 10 & 5KHz	
6	Teflon - 30KHz	
<b>Process Connection</b>		
FA	ANSI Flange	
FD	DIN Flange	
FJ	JSI Flange	
SB	BSP 30KHz only	
SN	NPT 30KHz only	
XX	Not Required	
<b>Process Connection Size</b>		
02	2 inch thread	30KHz only
04	4" Flange only	Standard on 20KHz
06	6" Flange only	
08	8" Flange only	
10	10" Flange only	Standard on 10KHz & 5KHz
XX	Not reqd	
Z	Special	
<b>Flange Material</b>		
4	Polypropylene	
6	Teflon	
7	Carbon Fibre	
X	Not required	
Z	Special	
<b>Cone</b>		
XX	Not required	
04	4"	Standard on 20KHz
10	10"	Standard on 10KHz & 5KHz
<b>Cone Material</b>		
4	Polypropylene	
6	Teflon	
7	Carbon Fibre	
8	Polyurethane	
X	Not required	
Z	Special	
<b>Approvals</b>		
X	Without	
M	ATEX EExm *	
D	ATEX DIP *	
<b>Connection Electrical</b>		
C	IP68 with 6 Mtr Cable	
Sxx	Designates Spec, Cable or Plug	

MSA	A	10	T	6	SB	XX	X	XX	X	X	C	Typical Part Number
-----	---	----	---	---	----	----	---	----	---	---	---	---------------------

\*For ATEX models refer to ATEX Safety & Operating Instructions Manual.

## 6. LABELLING INFORMATION.

Standard label fitted to all Microflex LR - Smart Transmitters.



## 7. MODBUS REGISTER LIST

### BASIC MODBUS SPAN AND DIAGNOSTIC REGISTERS FOR HYCONTROL MICROFLEX LR - SMART TRANSMITTERS

Hycontrol Smart Transmitters communicate using '2 wire' (plus Ground) RS485 connection, and can be connected in 'multi-drop' configurations.

**Protocol: Modbus RTU (2 wire)**

**Speed: 19200 Baud**

**Data bits: 8**

**Parity: None**

**Stop Bits: 1**

Smart Transmitters act as 'slave' devices on a Modbus network.

Units are shipped from the factory with a default Modbus address of 01. The Modbus address of any transmitter can be changed individually if transmitters are to be connected in a multi-drop network. Each address number must only be used once on any network (possible addresses are 1...255).

Diagnostic Block (*Read Only*): \*Can be read as Singles or any Block wholly within the limits of this range of addresses\*

40124 -	LOW LEVEL span set point in mm
40125 -	HIGH LEVEL span set point in mm
40126 -	DISPLAYED DISTANCE (DISTANCE) in mm
40127 -	NOT USED
40128 -	NEW DISTANCE (E-DISTANCE) in mm
40129 -	CONFIRM DISTANCE (C-DISTANCE) in mm
40130 -	ECHO SIZE in Volts/102
40131 -	GAIN at Echo detection point in %/7.5
40132 -	NOT USED (Gain Limit)
40133 -	RECOVER GAIN currently being used in %/7.5
40134 -	NOISE in %/7.5
40135 -	TEMPERATURE in Degrees K/10 ((DegreesC+273.2)/10)
40136 -	NOT USED
40137 -	CONFIRM COUNTER current value
40138 -	HOLD COUNTER current value
40139 -	NOT USED
40140 -	WINDOW FORWARD POSITION in mm
40141 -	WINDOW BACK POSITION in mm

**Identity Information (*Read Only*): \*MUST Read as SINGLES-NOT BLOCKS\*:**

40002 - SERIAL NUMBER raw number



- 40018- FILL RATE parameter setting- in metres per hour/10
- 40019- EMPTY RATE parameter setting- in metres per hour/10
- 40020- DISPLAY MODE parameter setting- values defined as listed here:
  - 1-Volume
  - 2-Flow
  - 3-Material %
  - 4-Material
  - 5-Space
  - 6-Differential Output
  - 7-Average Material
- 40065- FLOW UNITS parameter setting- values defined as listed here:
  - 32-Litres
  - 33-Kilolitres
  - 34-Megalitres
  - 35-Cubic Metres
  - 36-Cubic Feet
- 40031- FLOW EXPONENT parameter setting- in raw units/100
- 40032- FLOW MAX parameter setting- in selected flow units per second/10
- 40033- LOW CUT OFF parameter setting- in mm
- 40033- OFFSET parameter setting- in mm (0-5000)
- 40021- LOCK CODE parameter setting- raw number
- 40022- FILL DAMPING parameter setting- raw number
- 40023- EMPTY DAMPING parameter setting- raw number
- 40064- ANALOG mode parameter setting- values defined as listed here:
  - 0- 4-20mA (4mA low, 20mA high- standard)
  - 1- 20-4mA (20mA low, 4mA high- inverted)
- 40448- GAIN parameter setting in %/7.5
- 40449- GAIN STEP parameter setting in %/7.5
- 40450- DISTANCE STEP parameter setting in mm
- 40451- THRESHOLD parameter setting in Volts/100
- 40452- BLANKING parameter setting in mm
- 40453- EMPTY DISTANCE parameter setting in mm
- 40454- TEMPERATURE ADJ parameter setting- raw number
- 40455- DISTANCE ADJ parameter setting in mm
- 40456- VELOCITY parameter setting Value/10000
- 40457- MAP DISTANCE parameter setting in mm
- 40458- MAP USED parameter setting in mm
- 40461- MAP MARGIN parameter setting in %/7.5
- 40434- RECOVER FIRST parameter setting in %/7.5
- 40435- RECOVER MAX parameter setting in %/7.5
- 40436- RECOVER INCREMENT parameter setting in %/7.5
- 40437- WINDOW parameter setting in mm
- 40438- WINFWD INC parameter setting in mm
- 40439- WINBACK INC parameter setting in mm
- 40440- CONFIRM parameter setting- raw number
- 40441- HOLD parameter setting- raw number
- 40442- TX VOLTAGE parameter setting in V/413.25
- 40445- NOISE SWITCH parameter setting in %/7.5
- 40446- ECHO WIDTH parameter setting in mm

- 40433- SEARCH FIRST parameter in %/7.5
- 40034- MOVEMENT parameter setting in mm
- 40419- SLOPE DIST parameter setting in mm
- 40420- SLOPE INC parameter setting in %/7.5
- 40421- DETECTOR parameter setting in V/1240.7
- 40422- GAIN STEP1 parameter setting in %/7.5
- 40423- DISTANCE STEP1 parameter setting in mm
- 40424- GAIN STEP2 parameter setting in %/7.5
- 40425- DISTANCE STEP2 parameter setting in mm
- 40426- GAIN MAX parameter setting in %/7.5
- 40427- PULSE POWER parameter setting- raw number
- 40428- PULSE RATE parameter setting- raw number
- 40429- FREQUENCY parameter setting- raw number
- 40430- FILTER parameter setting- raw number
- 40431- ADVANCED FILTER parameter setting- raw number
- 40026- I-WASTE parameter setting in mA/1000
- 40035- I-CHARGE parameter setting in mA/37.22

**8. ASSEMBLY OF FLANGE AND CONES.**  
5, 10 & 20 KHz – Transmitter Assembly Process

1. Remove red cap (including cardboard).



2. Screw the flange assembly down onto the cone (as far down as it will go until the parts are tightly fastened).



3. Screw the transmitter tightly down onto the flange and cone assembly.



4. Tighten the locking ring down to the flange to fix the components in place.



**COMPLETED  
ASSEMBLY**