



## HYC3600U

### Single Channel Universal Input 6 Digit Indicator



Hycontrol Ltd, Larchwood House, Orchard Street,  
Redditch, Worcestershire, B98 7DP.

Tel: 01527 406800 Fax: 01527 406810

Email: [sales@hycontrol.com](mailto:sales@hycontrol.com) Website: [www.hycontrol.com](http://www.hycontrol.com)

## INDEX

SECTION	CONTENTS	PAGE NO.
1.0	DESCRIPTION	1
2.0	UNPACKING	1
3.0	INSTALLATION	2-3
4.0	OPTION PODS	4-5
5.0	CONFIGURATION OPTIONS	5
6.0	MECHANICAL	6-7
7.0	SPECIFICATION	7-10
8.0	INSTRUMENT CONFIGURATION	10-11
9.0	MENU MODE	11-12
10.0	MENU MAP	13
11.0	RESETTING THE DEVICE	13
12.0	INPUT MENU STRUCTURE	14-17
13.0	OUTPUT MENU STRUCTURE	18-20
14.0	SYSTEM MENU STRUCTURE	21-22
15.0	FAULT FINDING	23

## 1.0 DESCRIPTION

The DM3600 is a highly accurate and stable digital process indicator that accepts all commonly used process signals. The unit can be used "stand alone" or with the Modbus serial communications option, as part of a larger system. The case design enables Option Pods to be easily installed without the need for dismantling or re-calibration. A range of Pods are available for:

- Relay outputs
- Isolated (4 to 20) mA re-transmission

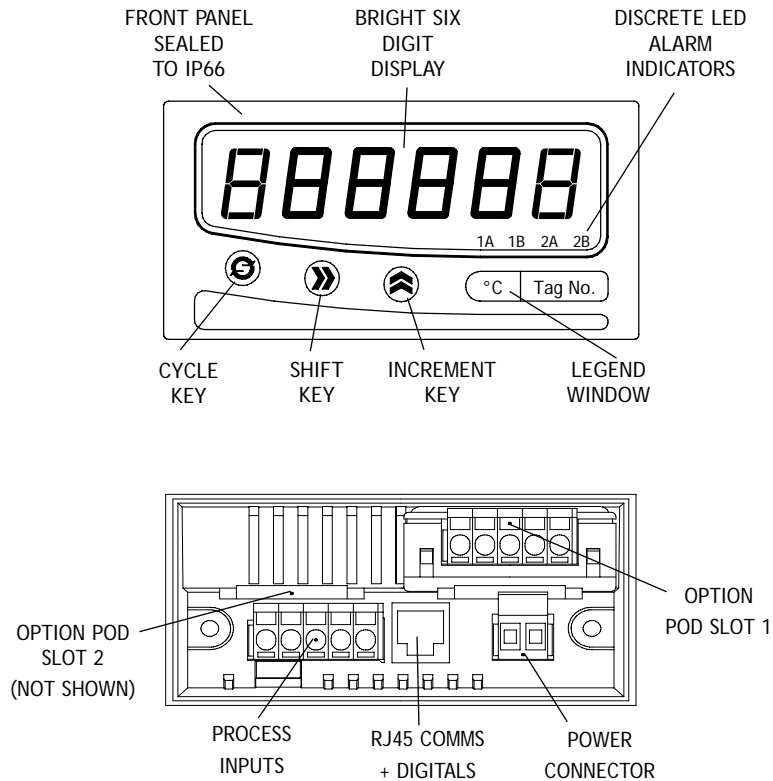

The diagram below shows the rear panel positions for all electrical connections.

## 2.0 UNPACKING

Please inspect the instrument carefully for any signs of shipping damage. The packaging has been designed to provide maximum protection, however, we cannot guarantee that mishandling will not have damaged the instrument. In the case of this unlikely event, please contact your supplier immediately and retain the packaging for subsequent inspection.

## 3.0 INSTALLATION (Read the following safety information before installation)

### ● WARNING !

- **INSTALLER** - This section must be used by competent personnel only. If this equipment is not installed in accordance with these instructions, protection against electrical hazards may be impaired. It is the responsibility of the person installing this equipment to implement this procedure in accordance with the relevant code of practice (for the installation of instrumentation used in process control systems), issued by a recognised local body.
- **MOUNTING** - This equipment is classed as **PERMANENTLY CONNECTED EQUIPMENT**. Hazardous voltages may be present on the terminals of this equipment. The equipment must be panel mounted into a suitable enclosure which provides at least IP20 protection behind the panel.
- **SUPPLY** - The supply terminals and associated internal circuitry are isolated from all other parts of the equipment in accordance with BS EN61010-1, for connection to an installation over-voltage Category II supply, (pollution degree 2). The supply voltage and frequency must remain within the limits stated on the product label. The mains supply to the unit must be protected by an external 1 A fuse and a suitable switch or circuit breaker must be located close to the equipment, in order to isolate the supply.
- **SIGNAL INPUT/OUTPUTS** - All signal input, and communication terminals and associated internal circuitry are intended for operation at voltages less than 40 VDC. These circuits, which may become accessible during NORMAL OPERATION, must ONLY be connected to signals complying with the requirements for Safety Extra Low Voltage (SELV) circuits.
- **RELAYS** - The relay terminals and associated internal circuitry are isolated from all other parts of the equipment in accordance with BS EN 61010-1, for connection to an installation over-voltage Category II supply, (pollution degree 2). The relay operating voltage and current must remain within the limits stated. (Refer to Section 7.0).
- **SERVICE** - This equipment contains no user serviceable parts and must be returned to supplier for repair.

### 3.1 INSTALLING INTO A PANEL

The maximum panel thickness is 10 mm. The instrument case has an integral gasket which forms a seal when the instrument is tightened against the panel. The panel should be clean, smooth and at least 1.6 mm thick for the seal to be effective.

#### **WARNING**

Use only the retaining screws provided to clamp the instrument to the panel (screws must be tightened sufficiently to effect a seal but must never be over tightened).

### 3.2 WIRING

All connections are made to sockets which are removable for ease of maintenance.

**NOTE: CABLE SIZE (0.5 to 1.5) mm<sup>2</sup>**

### 3.3 POWER SUPPLY

The Power supply rating will be indicated on the top of the instrument, ENSURE IT IS CORRECT FOR THE APPLICATION.

THE MAINS SUPPLY TO THE EQUIPMENT MUST BE PROTECTED BY AN EXTERNAL 1 A FUSE AND A SUITABLE SWITCH OR CIRCUIT BREAKER WHICH SHOULD BE NEAR THE EQUIPMENT.

NOTE: USE 600 VRMS CABLE (0.5 TO 1.5) mm<sup>2</sup>.

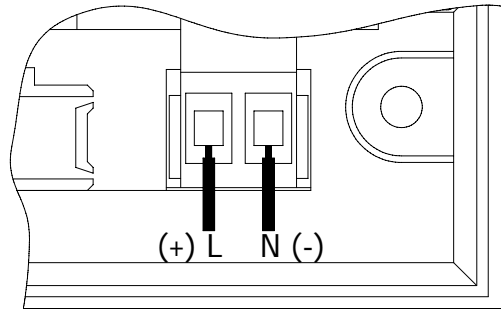

Wires are retained by screws. Ensure that the exposed section of the wire is fully inserted and that no loose strands are exposed.

### 3.4 SENSOR CONNECTIONS

All sensor connections are made via the five way "fast wiring" socket at the rear of the unit (wire size (0.5 to 1.5) mm<sup>2</sup>).

NOTE: THERMOCOUPLE, RTD AND VOLTAGE INPUT A SCREENED CABLE IS RECOMMENDED FOR RUNS GREATER THAN 10 m.

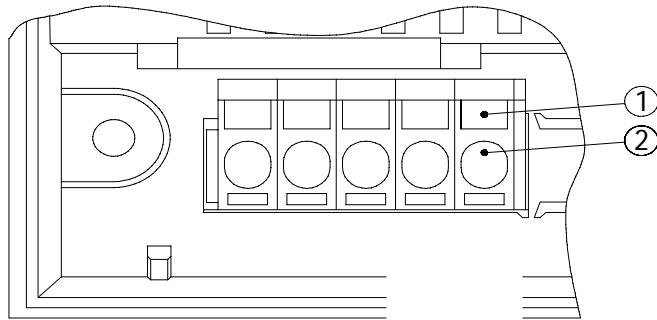

To make a connection: Insert small screwdriver blade into tension clamp orifice (1), push and twist to deflect clamp into open position. Do not lever screwdriver thus forcing connector body sideways. Insert conductor tail sufficiently into (2) then release screwdriver. Ensure no loose wire strands protrude.

### 4.0 OPTION PODS

#### 4.1 INSTALLING PODS

Power must be removed from unit before adding/removing a pod. Slot 1 (alarm 1A and 1B) should be positioned on the left side of the unit looking from the front to correspond to front panel alarm indicator, Slot 2 (alarm 2A and 2B) is positioned on the right.

To install an Option Pod, slide back the cover to its next engaging position and push the pod connection within the mating connector. To remove an Option Pod, disengage the supporting latch situated beneath the pod by pushing the back cover forward, the pod can then be lifted away from the instrument connector.

#### 4.2 DUAL RELAY POD. POD-3000/02000000

The relay pod has two "change over" relays with a common wiper.

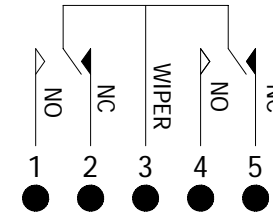

NOTE: USE 600 VRMS CABLE (0.5 TO 1.5) mm<sup>2</sup>

NOTE: ANY CIRCUIT WITH AN AC POTENTIAL GREATER THAN 33 VRMS AND 46.7 V PEAK MUST BE PROTECTED WITH A 5 A(T) FUSE WHEN CONNECTED TO THIS POD.

### 4.3 ISOLATED (4 TO 20) mA RE-TRANSMISSION POD. POD-3000/03

The re-transmission pod (when fitted) is designed to provide (0 to 10) mA, (0 to 20) mA or (4 to 20) mA output in active or passive modes. The output can be any portion of the display. The pod can be used in two modes:

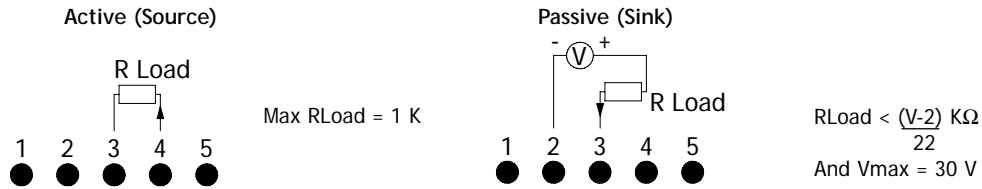

### 5.0 CONFIGURATION OPTIONS

Configuration can be performed in two ways. The first configuration method is to use the menu structure interface, standard on every DM3600 unit. The second configuration method is to use the optional factory fitted MODBUS RS485 communications option. To enable easy configuration via comms, the user can download M-Config from [www.status.co.uk](http://www.status.co.uk). This is a free Windows application to allow the user to easily and intuitively configure DM3600 devices. For more information regarding the DM3600 MODBUS implementation, please contact your supplier.

### 5.1 COMMUNICATION/DIGITAL INPUT OPTION

When fitted this option provides the user with either 4 or 2 wire RS485 serial communications together two digital inputs. Connections are made via a RJ45 connector. A 0.5 m interface is supplied with this.

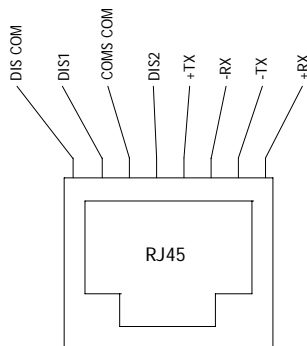
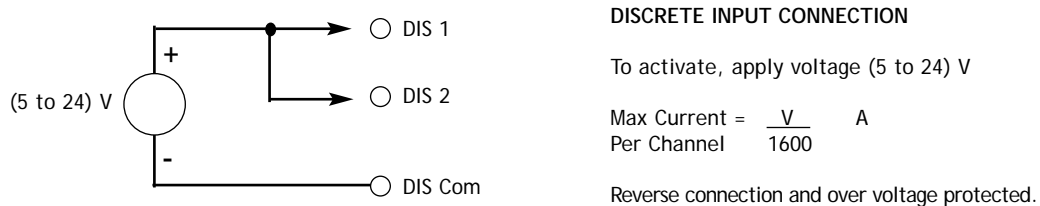

### 6.0 MECHANICAL DETAILS

Material	ABS/PC
Flammability	IEC707 FV0, UL 94V0
Weight	230 g
Panel cut out	(92 x 45) mm

All dimensions are in mm

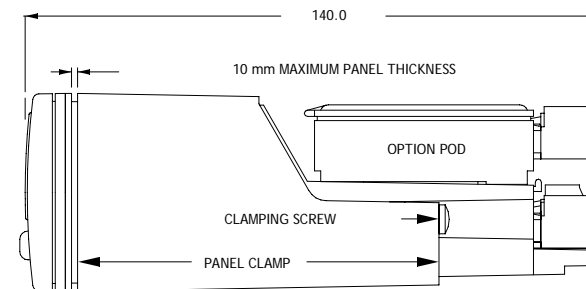
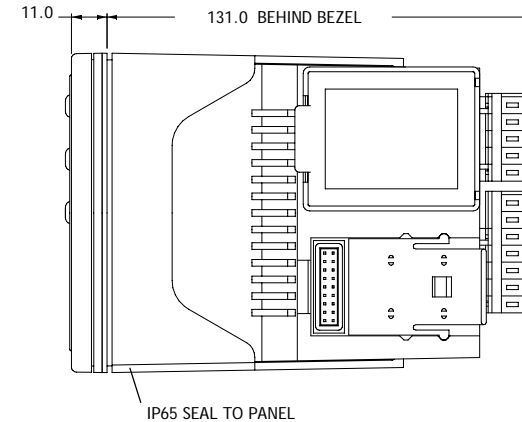
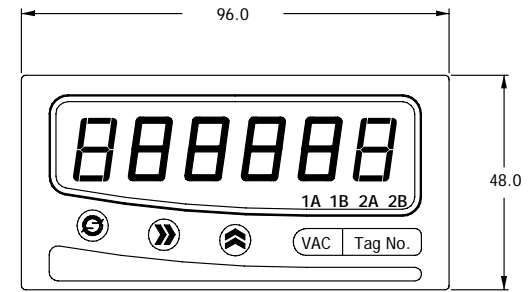

## 6.2 OPTION POD

All dimensions in mm

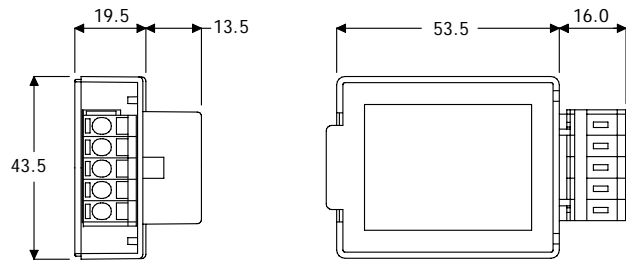

## 7.0 SPECIFICATIONS @ 20 °C

### UNIVERSAL INPUT TYPES

SENSOR	RANGE AND LINEARISATION
mA	4 to 20, $\pm 20$ , $\pm 10$
RTD	Pt100, Ni120, Custom*1
T/C	K, J, T, R, S, E, L, N, B, Custom*1
mV	$\pm 100$ mVDC
Volts	$\pm 10$ V, $\pm 5$ V, (1 to 5) V, $\pm 1$ VDC
Minimum Span	Any span within the range can be selected, but the recommended span is > 10 % of range

CURRENT INPUT	
Basic Accuracy	0.05 % FS $\pm$ 0.05 % of reading*2
Thermal Drift	0.02 %/°C
Input Impedance	20 $\Omega$
Linearity	Linear, $X^{1/2}$ , $X^{3/2}$ , $X^{5/2}$ , Custom*1

A 19.5 V  $\pm$  0.5 V @ 25 mA isolated power supply is available to power the current loop. (Short circuit protected)

RTD	
Sensor Range	(-200 to 850) °C (18 to 390) $\Omega$
Linearisation	BS EN60751/JISC1604/Custom*1
Basic Accuracy	0.1 °C $\pm$ 0.05 % of reading*2
Thermal Drift	Zero: 0.004 $\Omega$ 1 °C Span: 0.01 %/°C
Excitation Current	1 mA
Lead Resistance Effect	0.002 °C/ $\Omega$
Max Lead Resistance	50 $\Omega$ /leg

### \*NOTES

1. Custom can be up to 60 co-ordinate pairs or up to 7 segments of 15<sup>th</sup> order polynomial
2. Full accuracy for any span > 10 % of range.

## THERMOCOUPLE

TYPE	RANGE (°C)
K	-200 to 1370
J	-200 to 1200
T	-210 to 400
R*3	-10 to 1760
B*4	0 to 1700
S*3	-10 to 1760
E	-200 to 1000
L	-100 to 600
N	-180 to 1300
Custom	-999 to 9999

Accuracy	$\pm 0.04$ % FS or $\pm 0.04$ % reading or $\pm 0.5$ °C, whichever is greater*2
Linearisation	BS 4937/IEC 584-3/Custom*1
Cold Junction Error	$\pm 0.5$ °C
Cold Junction Tracking	0.05 °C/°C
Cold Junction Range	(-20 to 60) °C
Thermal Drift	Zero: 4 $\mu$ V/°C Span: 0.02 %/°C

VOLTAGE INPUT	
Basic Accuracy	0.04 % FS $\pm$ 0.04 % of reading*2
Thermal Drift	0.01 %/°C
Input Impedance	1 M $\Omega$
Linearity	Linear, $X^{1/2}$ , $X^{3/2}$ , $X^{5/2}$ , Custom*1
Range	$\pm 100$ mV, $\pm 1$ V, $\pm 5$ V, $\pm 10$ V, (1 to 5) V

### \*Notes

1. Custom can be up to 60 co-ordinate pairs or up to 7 segments of 15<sup>th</sup> order polynomial
2. Full accuracy for any span > 10 % of range
3. Accuracy true for (500 to 1760) °C
4. Accuracy true for (400 to 1650) °C

### GENERAL

Filter (Seconds)	None, Programmable (fixed), Adaptive
Power Supply	S1: (90 to 264) VAC 50/60 Hz (for UL LVD Compliance) S2: (20 to 35) VDC
Power Consumption	10 VA (worst case) 6 VA typical
Breakdown Isolation	I/O Ports 500 V

### ENVIRONMENTAL

Sealing to Panel	IP65
Ambient Operating Range	(-30 to 60) °C
Ambient Storage	(-50 to 85) °C
Ambient Humidity	(10 to 90) % RH

### EMC

Emissions	BS EN61326 Class A
Immunity	BS EN61326 Annex A
Safety	BS EN61010-1

## DM3600 5 WAY I/P CONNECTION

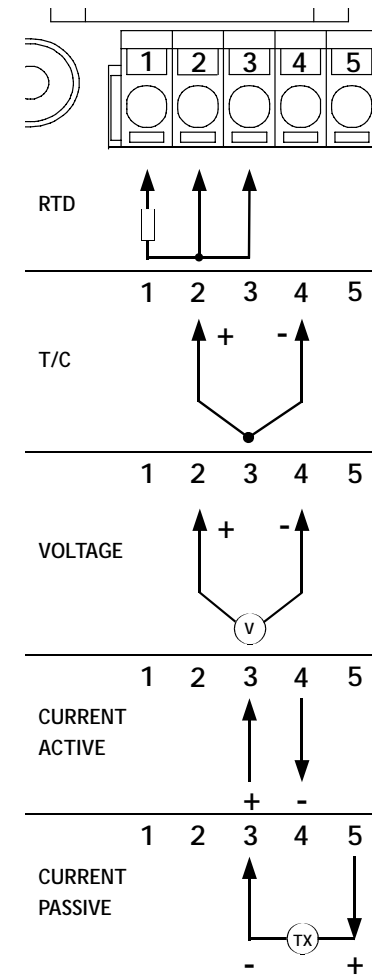

## REMOTE DIGITALS OPTION

Two isolated digital inputs are available to reset latched alarms, clear peak/valley readings, or for customised use with TFML.

### 7.1 PLUG AND PLAY OPTION PODS

Simple plug in pre-calibrated units, no dismantling or re-calibration.

#### POD-3000/02 DUAL RELAY ALARM

Two independent mains rated relay outputs

Contacts	2 x changeover relays with common wiper
Ratings	AC, DC
Maximum Load	5 A @ 250 V, 5 A @ 30 V
Min Load	100 mA
Maximum Power	1250 VA, 150 W
Maximum Switching	253 V, 125 V
Electrical Life	1 M operations at rated load
Mechanical Life	50 M operations
Termination	Standard 5 way tension clamp connector Optional Screw terminals
Pulse Mode	Pulse period 100 ms

#### POD-3000/03 ISOLATED RE-TRANSMISSION

Ranges	(0 to 10) mA (Active or Passive) (0 to 20) mA (Active or Passive) (4 to 20) mA (Active or Passive)
Minimum Current Output	0 mA
Maximum Current Output	23 mA
Accuracy	0.07 % F.S.
Resolution	1 part in 30 000
Max. Output load	See Section 4.3
Max. Ext. Supply Voltage	30 V (Passive mode)
Voltage Effect	0.2 $\mu$ A/V
Ripple Current	< 3 $\mu$ A
Isolation	500 VAC
Stability	1 $\mu$ A/°C
Termination	Standard 5 way tension clamp connector Optional Screw terminals
Voltage Outputs	Voltage Outputs may be obtained by connecting a external resistor and selecting the appropriate current range, as shown in the table below.

RESISTOR	CURRENT RANGE	OUTPUT
1 K $\Omega$	(0 to 10) mA	(0 to 10) V
500 $\Omega$	(0 to 20) mA	(0 to 10) V
250 $\Omega$	(4 to 20) mA	(1 to 5) V

#### CONNECTIONS

Input	5 way tension clamp connector (2 part)
Comms + Digital	8 way RJ45 (Supplied with matching plug and 1 m cable)

## 7.2 COMMUNICATIONS OPTION

### RS485 MODBUS Communications

DM3600 is available with RS485 serial communications using MODBUS RTU protocol, and can be used with Status' own M-Config software.

Physical Layer	4 wire or 2 wire half duplex RS485
Protocol	MODBUS RTU format
Breakdown Isolation	500 VAC
Maximum Fan out	32 units (can be increased with repeaters)
Termination Standard	RS485

### 8.0 INSTRUMENT CONFIGURATION

The DM3600 is configured using the three keys on the front panel. The unit has two modes of operation:

The first is 'Run' mode. This will automatically be entered 5 s after power up. This is the principle mode of operation. There are 6 possible key press combinations, as shown in the 'Key Press Definitions' diagram below. The 'Run Mode Options' diagram shows the key presses required to access various states from the run mode. (See diagram in Section 8.2 overleaf).

The other principle mode of operation is 'Menu Mode'. The menu navigation method is shown diagrammatically in the 'General Menu Structure' (see Section 9.1).

Once the menu mode has been accessed, the user can use the large 'Menu Map' (see Section 10.0) to navigate through the menu structure.

#### 8.1 KEY PRESS DEFINITIONS

All programming is done using the three front panel keys, A, B and C.

ESCAPE (A & B), ENTER (B & C) and CLEAR (A & C) are obtained by simultaneously pressing the two keys.

CYCLE (A), SHIFT (B) and INC (C) keys are pressed singularly.

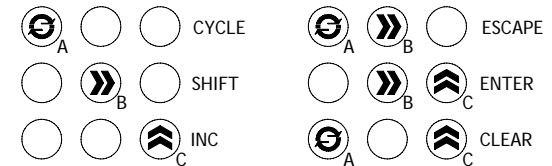

## 8.2 RUN MODE OPTIONS

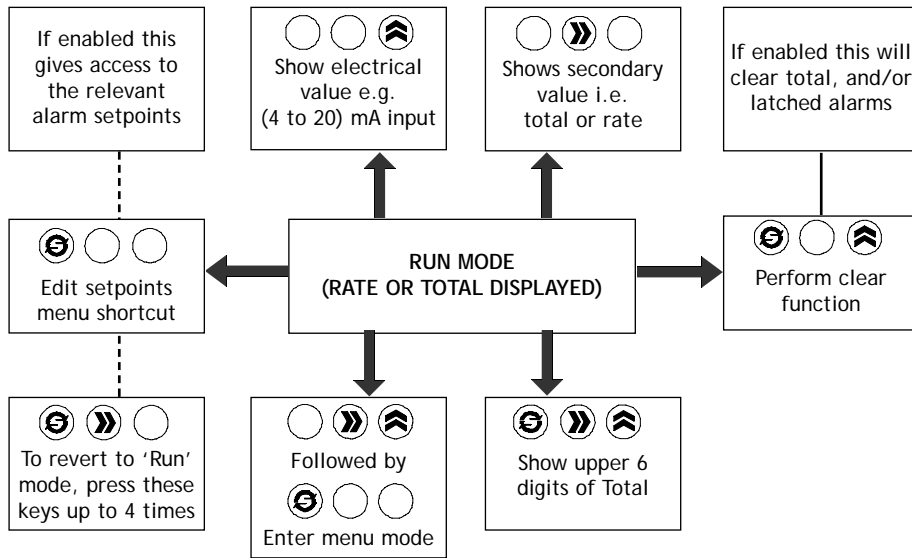

## 9.0 MENU MODE

This menu configures the unit to suit the application. The menu covered in this section is the menu structure for all applications.

The 'Menu' mode is protected by a passcode and the user is asked for this when the 'Menu' mode is accessed from the run mode. The passcode is set to the default of 0 and can be changed to any value between 0 and 65535, setting the value to zero (default) removes the passcode prompt and the passcode function is disabled.

## 9.1 GENERAL MENU NAVIGATION

The diagram below describes how to move around the menu structure and enter data. More specifically it details:

1. How to enter a real number
2. How to choose an option from a list
3. How to enter and navigate around a submenu

Using these three procedures the user can enter all applicable data to configure the unit to suit the application. The options displayed depends on whether the short menu or full menu option is enabled (This can be selected in the **SYSTEM** submenu).

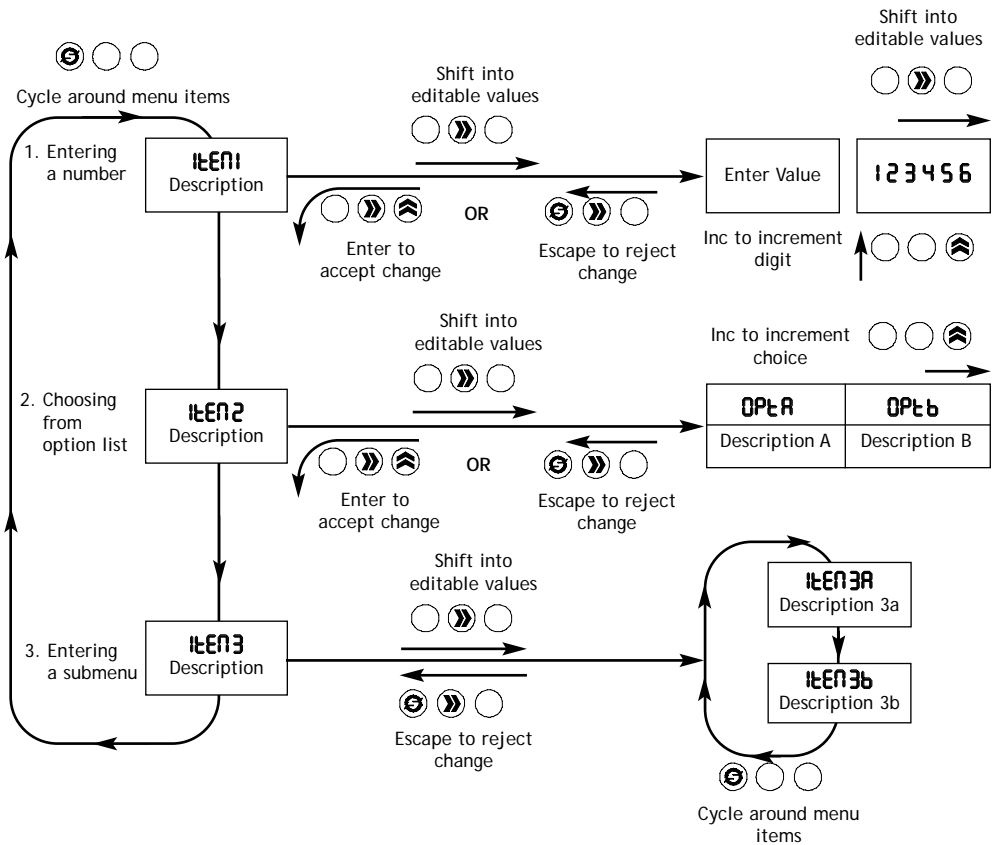

## 10.0 MENU MAP

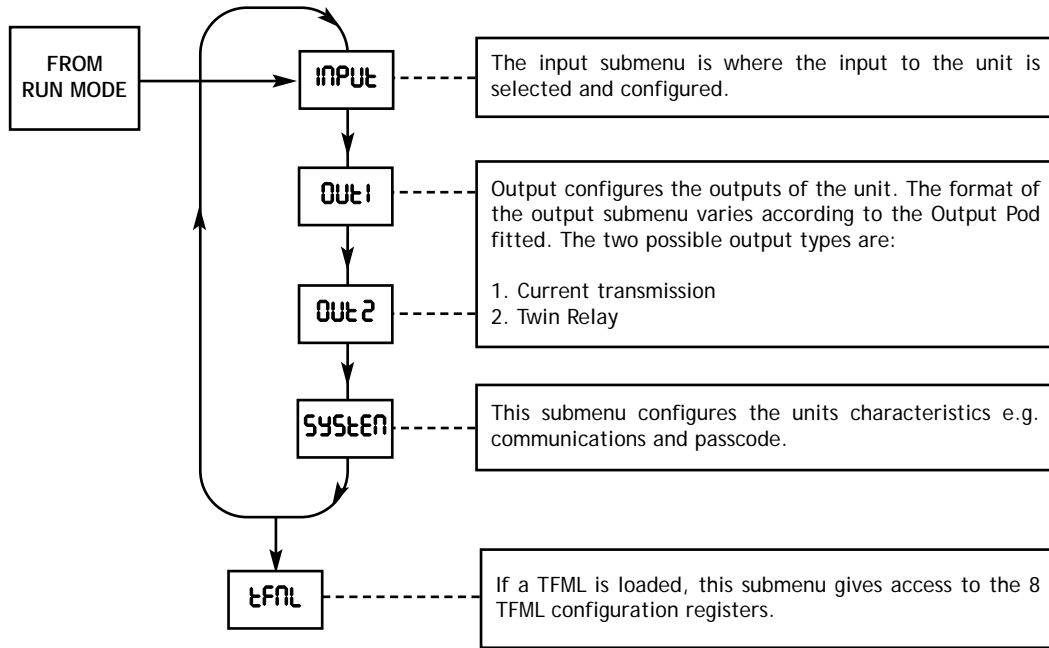

## 11.0 RESETTING THE DEVICE

Holding down the Cycle key whilst applying power to the unit will cause all settings to revert to factory default.

USE THIS FUNCTION WITH CAUTION as there is no way of reversing it.

NOTE that this function will also clear any TFML module loaded.

## 12.0 INPUT MENU STRUCTURE

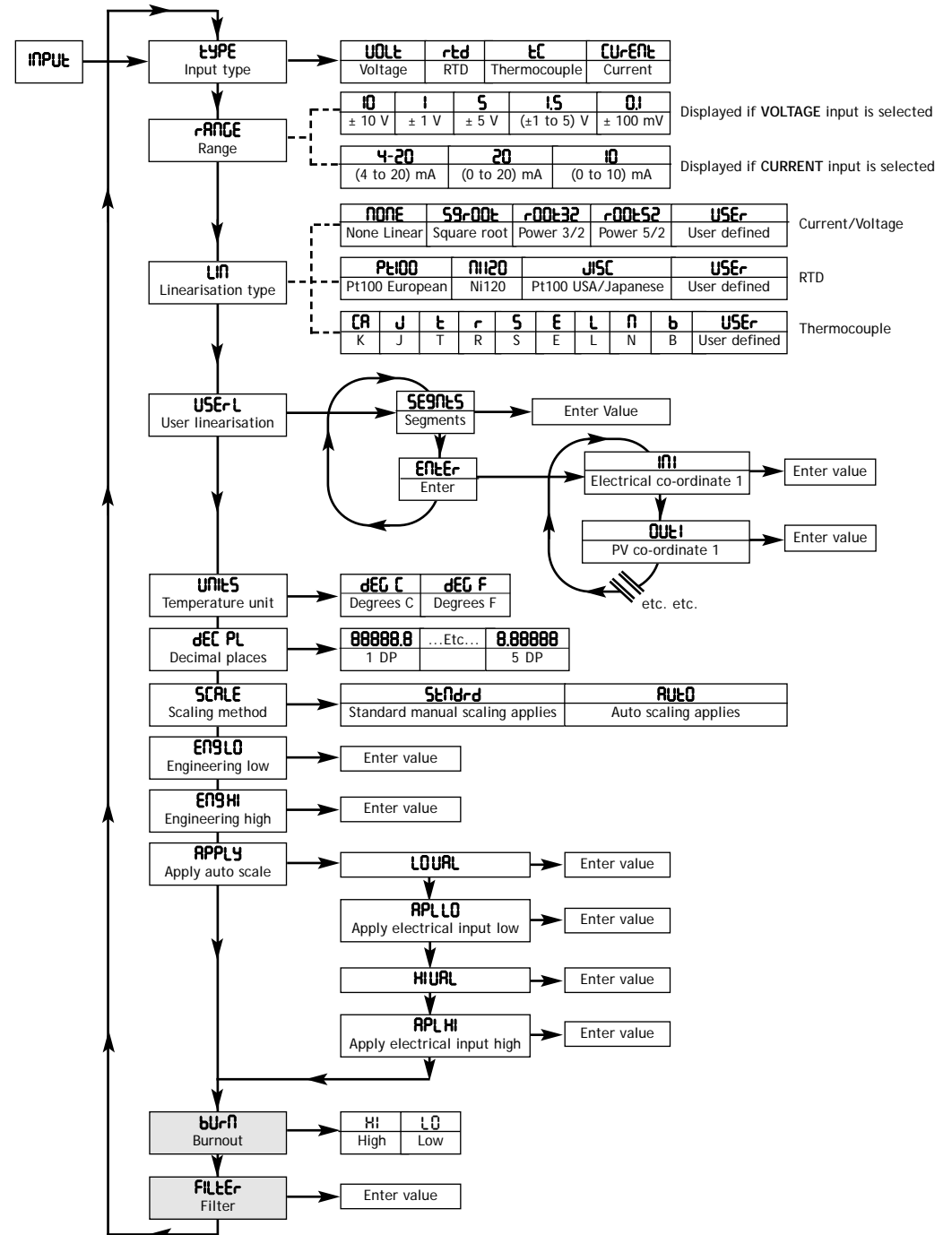

## 12.1 INPUT MENU BLOCKS

### TYPE

This allows the type of input on the unit to be selected. The DM3600 accepts a Voltage, RTD, Thermocouple or Current Input.

### RANGE

Depending on the input type selected the DM3600 will either show the voltage ranges or current ranges available. Select the range which is applicable to the input device.

### LINEARISATION TYPE

The input type selected will determine the linearisation options available. Current/Voltage, RTD or Thermocouple.

### USER LINEARISATION

When the user selects user linearisation, up to 60 co-ordinate pairs of interpolation data can be entered via the front panel keys. The 'SEGMENTS' value defines the number of segments.

**SEGMENTS** = Number of interpolated segments = Number of co-ordinate pairs -1  
**IN1** = Electrical input co-ordinate 1  
**OUT1** = Process variable (PV) co-ordinate 1  
**IN2** = Electrical input co-ordinate 2  
**OUT2** = PV co-ordinate 2

etc.....

For n segments there are n + 1 co-ordinate pairs.

If the electrical input goes below electrical input co-ordinate 1, or above electrical input co-ordinate (n+1), the input is flagged as being under or over-range, respectively.

### TEMPERATURE UNITS

This is only available if a Thermocouple or RTD input is selected.

### DECIMAL PLACES

The number of decimal places shown on the display can be selected using this option.

### INPUT SCALING FUNCTIONALLY

The primary function of a DM3600 is to take an electrical input, and convert it to a displayable Process Variable (PV, also referred to as an engineering value, e.g. temperature or flow). The DM3600 input signal can be scaled in one of many ways. For 'RTD' or 'TC' inputs, the user is simply required to choose the 'TYPE' and 'LIN' (linearity type). For 'CURRENT' or 'VOLT' input types, the user can choose **Standard** or **AUTO** scaling (from the 'SCALE' sub-menu).

### ENGINEERING LOW / HIGH

If 'Standard' scaling is chosen, the user will encounter 'ENGLO' and 'ENSHI' entries, in order to manually scale the input to the relevant input\_lo and input\_hi values (see table overleaf for input\_lo/hi values). The PV\_lo & PV\_hi values shown overleaf equate to the 'ENGLO' and 'ENSHI' entries). Scaling is subsequently applied according to the graph overleaf. (The straight line illustrated overleaf will change if a non linear linearity type is selected. If the user requires strict control over out of range limits, user linearisation should be chosen).

### APPLY AUTO SCALE

If 'AUTO' scaling is selected, the 'APPLY' submenu appears (in place of 'ENGLO' and 'ENSHI' entries). The 'APPLY' submenu procedure must be carried out as follows.

1. Shift into 'APPLY' submenu.
2. Edit & Enter the 'LOURL' engineering value required for low scaling (This will equate to PV\_lo).
3. The display will flash 'APLLO' to prompt the user to apply the electrical signal corresponding to PV\_lo. If the electrical signal goes out of range, the display signifies this, and the input signal won't be accepted by the DM3600. This applied electrical signal equates to input\_lo, in the graph and table below.
4. Repeat Steps 2 & 3 for 'HIURL', and the corresponding high electrical/engineering values.

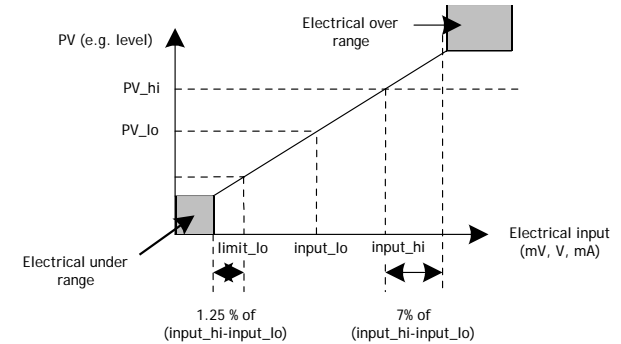



INPUT TYPE	RANGE	limit_lo	input_lo	input_hi
VOLTAGE	± 100 mV	-100 mV	0 mV	100 mV
	± 10V	-10 V	0 V	10 V
	± 1V	-1 V	0 V	1 V
	± 5V	-5 V	0 V	5 V
	(1 to 5) V	1 V	1 V	5 V
CURRENT	(4 to 20) mA	4 mA	4 mA	20 mA
	± 20 mA	-20 mA	0 mA	20 mA
	± 10 mA	-10 mA	0 mA	10 mA

### OUT OF RANGE ALARM

When an input goes out of range, the following occurs:

- If fitted, any relays go into alarm state
- If fitted, the re-transmission current derived from the out of range alarm input goes to 3.8 mA or 21.12 mA, depending on whether the burnout setting is set to low or high, respectively.

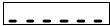
Once scaling is complete, and the menu structure is exited, if the electrical input is under/over range,

the display shows  or 

## FILTER

The user can choose one of three filter types by editing this configuration;

1. Entering a value of  $> 0.3$ . A fixed first order recursive filter is applied to the input processing, with a time constant (TC) equating to the actual value entered, in seconds.
2. Entering a value = 0.0. An adaptive first order recursive filter is applied to the input processing, with the time constant adapting to the dynamic behaviour of the input signal.
3. Entering a value  $x$ , where  $0 < x < 0.3$ . No filter is applied to the input processing.

## BURNOUT

This defines whether, in the event of a sensor failure (burnout), the output current goes high (21.5 mA) or low (3.6 mA). This is only available if the thermocouple or RTD input type is chosen.

## 13.0 OUTPUT MENU STRUCTURE

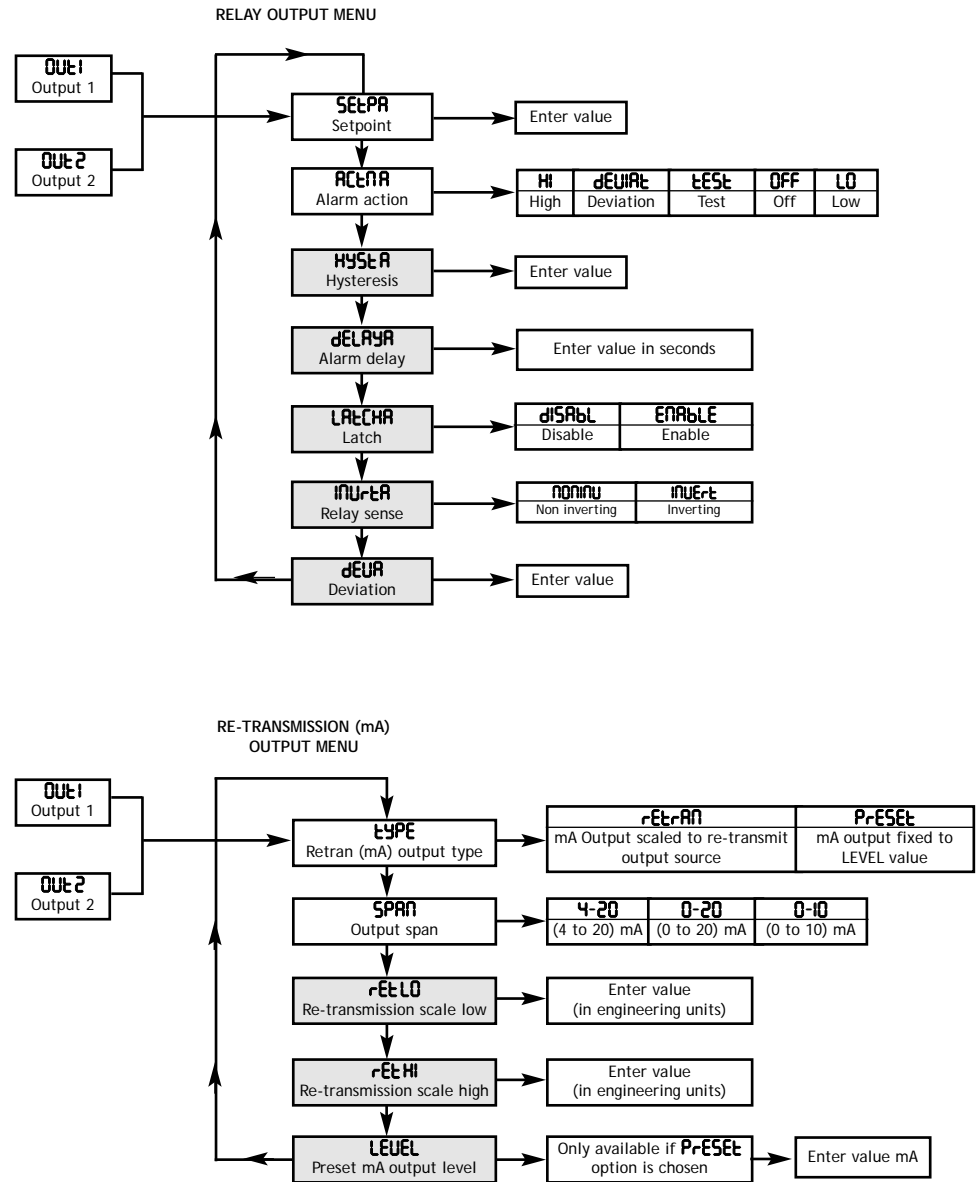

### 13.1 OUTPUT MENU FUNCTION BLOCKS

#### 13.2 RELAY OUTPUT MENU

The relay menu shown is for alarm A. There are two alarms A and B so the menu will be duplicated for alarm B. The relay menu will only be displayed if a twin relay pod is fitted to the DM3600.

##### SETPOINT A

The setpoint value defines the engineering value associated with an alarm. For example if an alarm is required when the flow exceeds 10 000 kg/h, the setpoint will be set to 10 000.

##### ALARM ACTION

This defines the behaviour of the alarm when the setpoint is reached.

ALARM ACTION	ALARM BEHAVIOUR
<b>OFF</b> (Off)	The alarm is always off
<b>LO</b> (Low)	The alarm triggers when PV < setpoint, i.e. low alarm
<b>HI</b> (High)	The alarm triggers when PV > setpoint, i.e. high alarm
<b>dEU</b> (Deviation)	The alarm triggers when PV moves out of a deviation band e.g. if the flow drops below or above the set point by 10 L/m.
<b>tEST</b> (Test)	Alarm is on

##### HYSTERESIS

The hysteresis value is the difference between the points at which the alarm triggers and releases, expressed in the relevant engineering units.

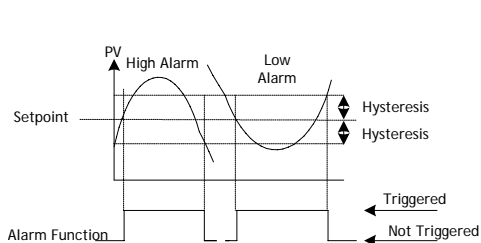

##### ALARM DELAY

The alarm will not trigger until the PV has been in the alarm region for more than the specified number of seconds.

##### LATCH

When latch is enabled, an alarm will remain triggered until it is manually cleared.

### RELAY SENSE

The 'INUrE' setting refers to the relay sense during powered operation. All other relay output menu settings refer to the alarm state. When in alarm, the relevant front panel LED is lit.

POWER	ALARM STATUS	INUrE SETTING	RELAY POSITION (A)	RELAY POSITION (B)
OFF	X	X	3 and 5	3 and 2
ON	Not in Alarm	NOUUrU	3 and 4	3 and 1
ON	In Alarm	NOUUrU	3 and 5	3 and 2
ON	Not in Alarm	INUrE	3 and 5	3 and 2
ON	In Alarm	INUrE	3 and 4	3 and 1

##### DEVIATION

If the 'dEU' action is chosen in the alarm action option, this value determines the amount by which the PV may change before the alarm is triggered. The value should be in the engineering units.

#### 13.3 RE-TRANSMISSION (mA) OUTPUT MENU

This menu is only displayed if a current re-transmission output pod is fitted. If 'PRESET' is chosen, the output current can be edited in 'LEVEL'. Otherwise, the re-transmitted current is derived linearly from the process variable, using 'rEELU' and 'rEELH'.

##### RE-TRANSMISSION OUTPUT TYPE

The re-transmission can be set to represent rate or total.

##### OUTPUT SPAN

(4 to 20) mA, (0 to 20) mA or (0 to 10) mA can be selected as the span of the re-transmission.

##### RE-TRANSMISSION SCALE LOW / HIGH

By entering these values, the user can scale the mA output (selected in SPAN) to the PV. Default values will be equal to the engineering low and engineering high values entered in the input menu.

##### PRESET mA OUTPUT LEVEL

This is only available if 'PRESET' output is chosen.

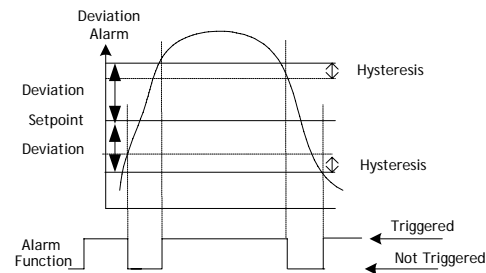

## 14.0 SYSTEM MENU

The system menu allows the communications to and from the device to be configured and also allows various functions to be enabled from the run mode. The passcode can also be changed from within this menu. (See menu below).

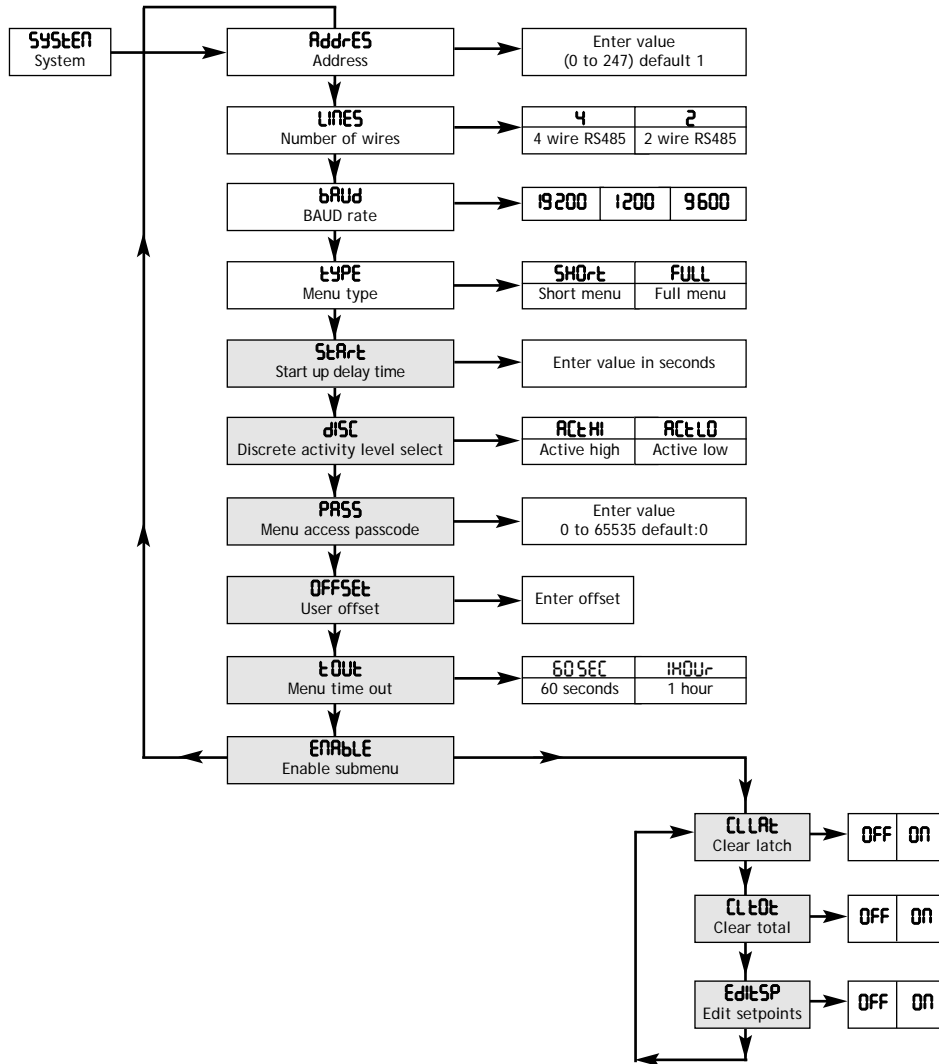

## 14.1 SYSTEM MENU FUNCTION BLOCKS

### MODBUS DEVICE ADDRESS

This sets the address for the RS485 communications. The default is 1 and the maximum is 247.

### NUMBER OF WIRES

This defines the type of RS485 communication mode. It can either be 4 (full duplex) or 2 (half duplex).

### BAUD RATE

This defines the comms baud rate i.e. the speed of communication between the unit and interrogating device. The Baud rate is displayed in bps.

### MENU TYPE

When 'SHORT' type is chosen, access to the greyed out menu items is restricted. To allow access to these items the 'FULL' menu type should be chosen.

### START UP DELAY TIME

The outputs of the unit will not operate until the start up delay time (measured in seconds) has expired. The minimum delay is 5 s and the maximum 3 600 s.

### DISCRETE ACTIVE LEVEL SELECT

The function of the discrete input 'DISC' is to operate as a remote clear button press, i.e. you can use this to reset the totals remotely. This menu item selects whether the clear function is executed when the discrete is high (24 V) 'ACTHI' or low (0 V) 'ACTLO'.

### MENU ACCESS PASSCODE

When accessing the menus from 'Run' mode, the user is prompted for this passcode. If it is zero (default), then there is no prompt and the password function is disabled. If the password is forgotten please contact your supplier.

### USER OFFSET

This value is used to offset the scaled process variable by a fixed amount.

### MENU TIME OUT

This sets the amount of time after which the display will revert to the 'Run' mode if no key is pressed.

### ENABLE

Enables the following sub-menu:

### CLEAR LATCH

When set to 'ON' latched alarms can be cleared by pressing the clear button on the front panel, or applying discrete input 1.

### CLEAR TOTAL

When set to 'ON', the total is reset by pressing the clear button on the front panel.

### EDIT SETPOINTS

When set to 'ON' the edit setpoints submenu can be accessed directly from the 'Run' mode.

15.0 FAULT FINDING

SYMPTOM	POSSIBLE CAUSE	ACTION
DISPLAY IS BLANK	No power	Check power supply connections
DISPLAY SHOWS <input type="text" value="-----"/>	Input is out of range (above maximum)	Check that the engineering high value is correct
DISPLAY SHOWS <input type="text" value="-----"/>	Input is out of range (below minimum)	Check that the engineering low value is correct
'dPErr' IS DISPLAYED	The displayed value (excluding total) is greater than 6 digits (i.e. 999999)	This can occur if the PV is configured outside of the displayable range
'OPCAL' IS DISPLAYED	The output pod has been corrupted	Re-configure output. If the error is still present replace the output pod
'IPCAL' IS DISPLAYED	The input calibrated data has been corrupted	Re-input calibration data. If the error is still present replace the unit



Hycontrol Limited, Larchwood House, Orchard Street,  
Redditch, Worcestershire, B98 7DP, UK.

Tel: 01527 406800 Fax: 01527 406810

Email: sales@hycontrol.com Website: www.hycontrol.com