

TWINFLEX AC & TWINFLEX DC
INSTALLATION INSTRUCTIONS

DESCRIPTION

Twinflex is a programmable multi-purpose level measurement instrument for use on liquids or slurries in vessels up to 10m deep. It can be used in single-channel mode or in two-channel mode to simultaneously monitor 2 similar or dissimilar vessels.

It can measure level or distance and will display in metres, feet or percentage of programmed span, providing a 4-20mA output proportional to the programmed span for each vessel.

Twinflex consists of a wall mounted transceiver and 1 or 2 transducers. The transducers can be located up to 100m from the Twinflex and must be mounted directly above the surface to be monitored.

Ultrasonic pulses are transmitted by the transducers to the surfaces being monitored and are reflected back to the transducers. The time period between transmission and reception of the sound pulses is directly proportional to the distances between the transducers and the targets.

Each channel has a green light on the front panel which illuminates when the instrument is processing a good signal for that channel.

IMPORTANT INSTALLATION REQUIREMENTS

- 1: A SWITCH OR CIRCUIT BREAKER SHALL BE INCLUDED IN THE INSTALLATION**
- 2: IT SHALL BE IN CLOSE PROXIMITY TO THE EQUIPMENT AND WITHIN EASY REACH OF THE OPERATOR**
- 3: IT SHALL BE MARKED AS THE DISCONNECTING DEVICE FOR THE EQUIPMENT**

INSTALLATION

Transceiver Mounting

Undo the 4 screws on the front panel and remove the lid to expose the 4 mounting holes moulded in the enclosure.

The location and mounting of the unit is important:-

Choose a flat surface not subject to vibration.

Avoid high voltage power cables, contactors and drive controls.

Avoid direct sunlight and protect it from severe weather conditions.

Do not use excessive force when tightening the mounting screws and avoid any distortion of the enclosure.

Remove the cover label from the 3 holes in the lower face of the enclosure and fit appropriate cable glands or conduit to maintain the I.P. rating.

Figure 1: Twinflex outline dimensions

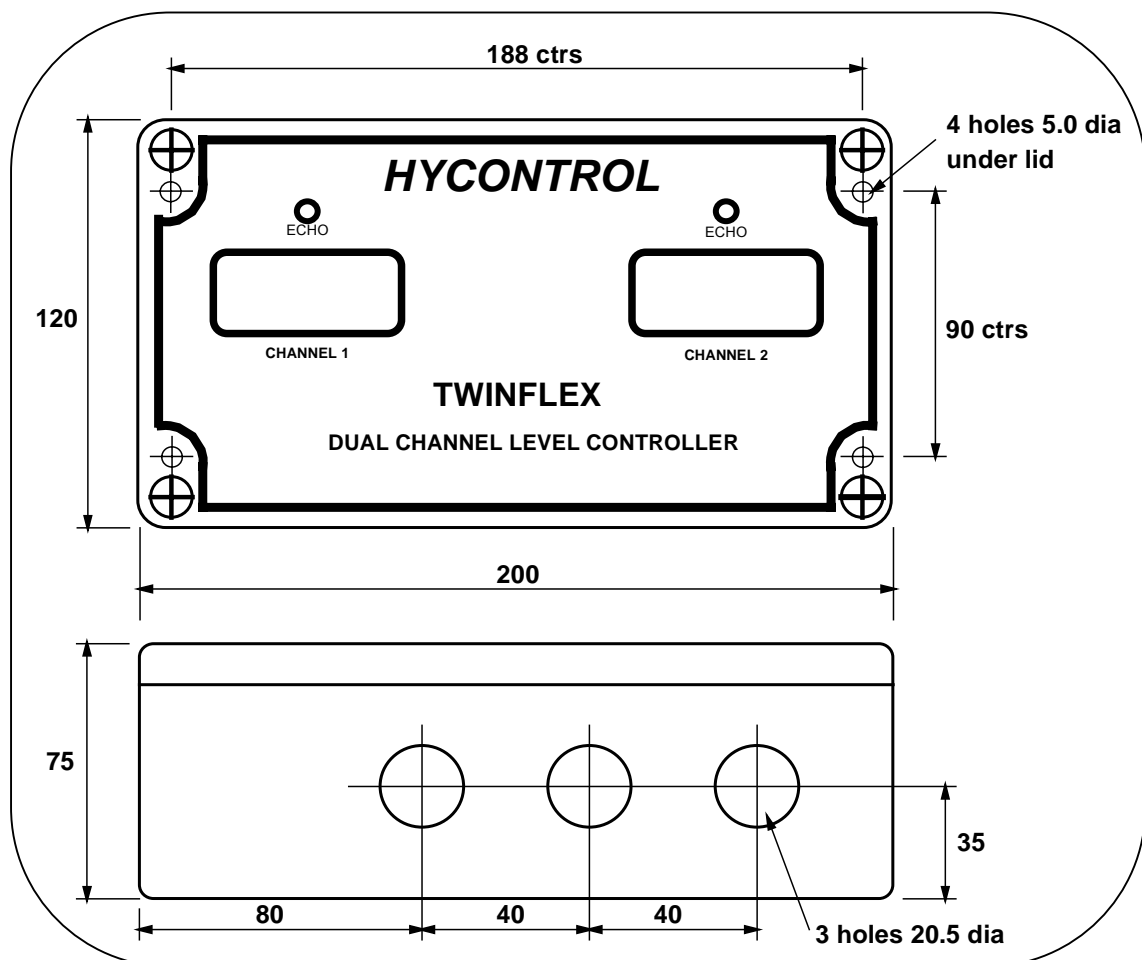

Electrical and Transducer Connections

Twinflex has two-part screw terminals; the top part can be removed for ease of connection.

TWINFLEX DC is for 21.6 – 30.0Vdc only.

TWINFLEX AC is for 110/230Vac +/-10% 50/60Hz or 21.6 – 30.0Vdc

Power Supply

Remove the clear terminal cover by unscrewing the two knurled screws.

Do not remove the black pcb cover; there are no connections or adjustments underneath.

Figure 2: Twinflex DC

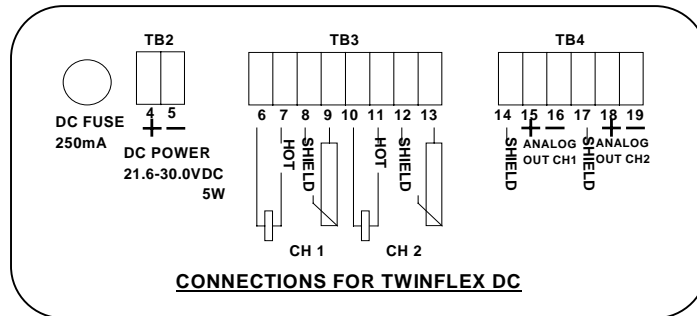
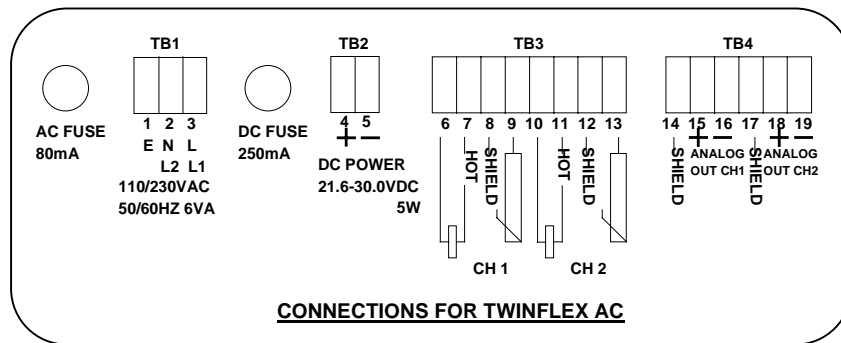

Figure 3: Twinflex AC



AC Supply select the voltage required using the manual switch fitted below the transformer.

For 110V put switch to position 1 – on left hand side (marked 110V on PCB)

For 230V put switch to position 2 – on right hand side (marked 230V on PCB)

REFIT THE TERMINAL COVER BEFORE POWERING UP THE UNIT

Transducer

Transducer	RZV15 series}	connect:-	Black	CH1	to terminal 6	CH2	to terminal 10
	RXV15 series}		Blue		to terminal 7	to terminal 11	
			Screen		to terminal 8		to terminal 12
	RZT15 series}	connect:-	Black	CH1	to terminal 9	CH2	to terminal 13
	RXT15 series}		Blue		to terminal 7	to terminal 11	
(Integral temperature sensor)			Screen		to terminal 6		to terminal 10

Analogue Output

Connect:-	Screen	CH1	to terminal 14	CH2	to terminal 17
	Pos +ve		to terminal 15		to terminal 18
	Neg -ve		to terminal 16		to terminal 19

Figure 4: Transducer cables can be extended as shown below:

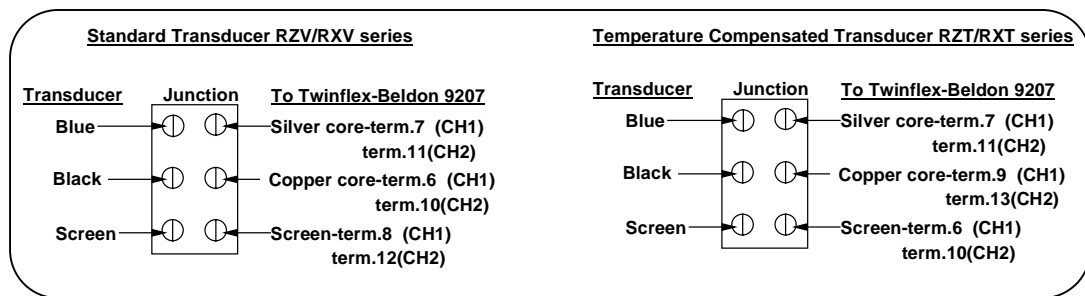

Transducer Mounting

The transducer can be supplied in standard construction or integral with a PTFE faced flange for applications requiring chemical compatibility.

Figure 5: Transducer outline dimensions

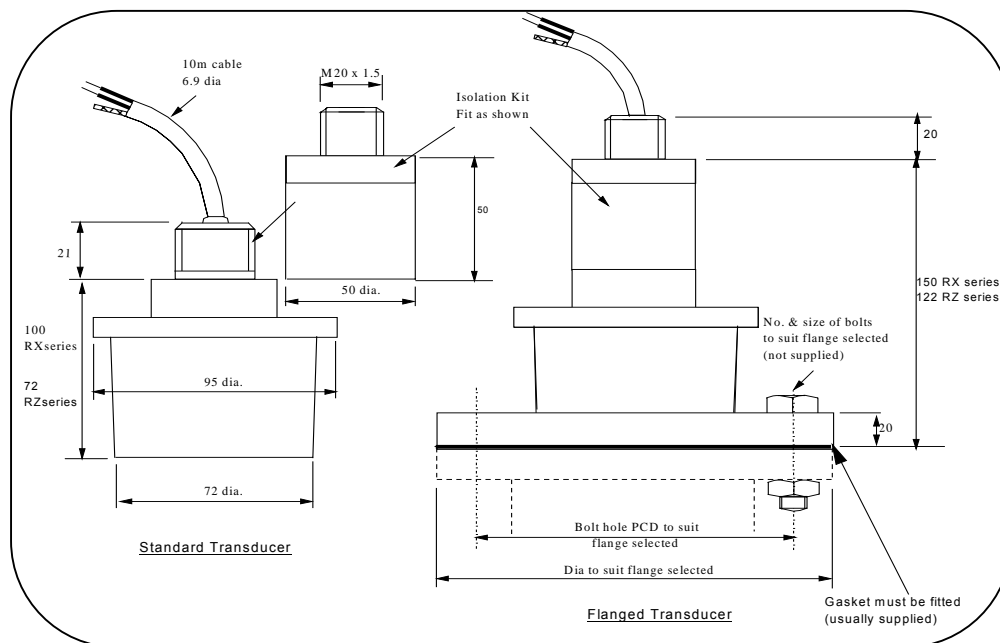

An isolation kit is provided with each transducer. This **must** be used with the standard transducer to minimize any ringing transmitted through the mounting structure. On the flanged transducer it provides an M20 thread for connecting conduit.

The transducer must be mounted perpendicular to the monitored surface and ideally at least 0.5m above the highest liquid level. The transducer has a 10° inclusive conical beam angle at 3dB and must be mounted with a clear, unobstructed sight of the liquid to be measured over the complete measurement range.

The transducer is usually provided with 10m integral cable which can be extended up to 100m using a suitable junction box and cables as detailed on page 3, Fig 4.

Transducer cables should be separated from power cables by at least 150mm and preferably installed in their own earthed steel conduit.

Figure 6: Alternative mounting arrangements for transducers

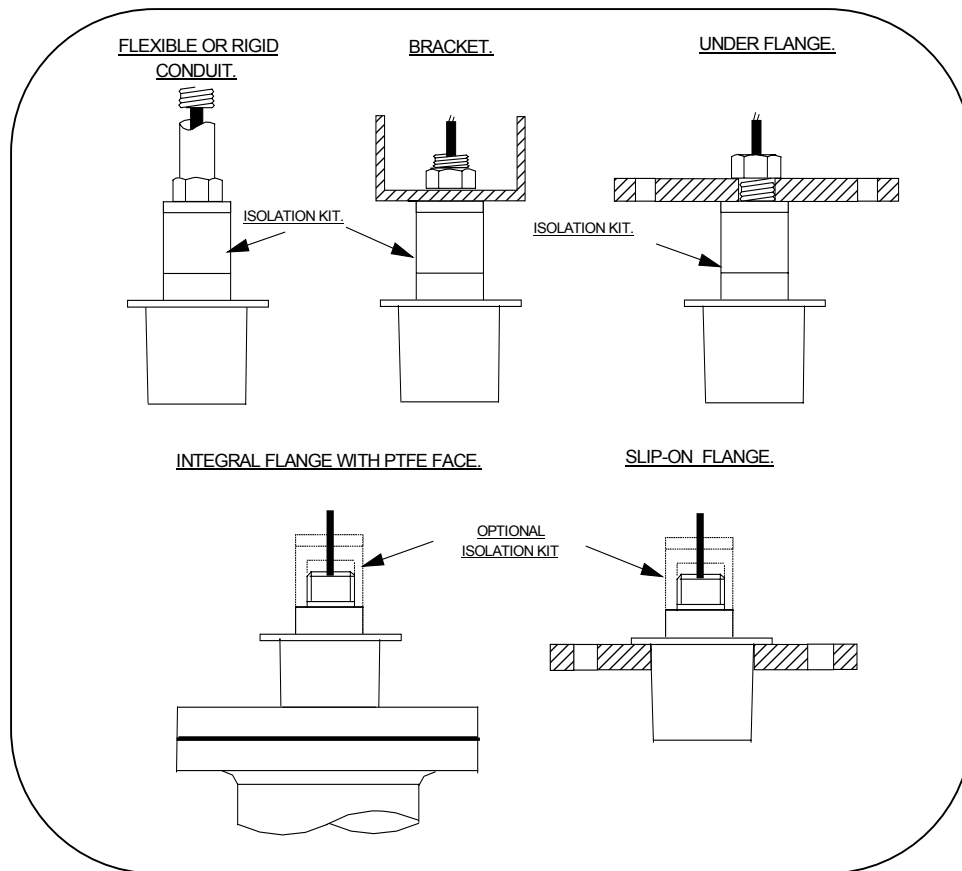

Transducer cables should be separated from power cables by at least 150mm and preferably installed in their own earthed steel conduit.

Do not mount transducers incorporating temperature compensation in direct sunlight.

Do not over-tighten the bolts on flange construction transducers.

Flanged transducers are not pressure rated, they are suitable only for atmospheric pressure. This applies also to **all CENELEC** approved transducers.

CENELEC approved transducers must be mounted and wired in accordance with the appropriate National Standards relating to installation in hazardous areas.

Figure 7:

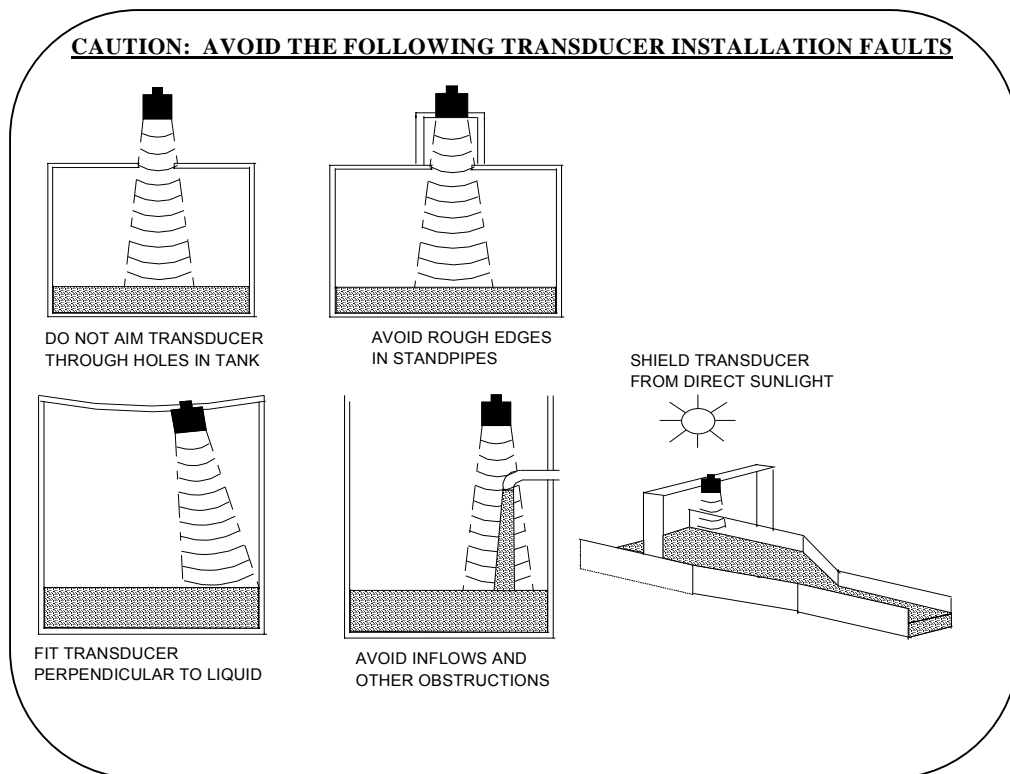

Standpipe Installations

In many applications access to a vessel must be made via a standpipe. However, it is necessary to observe some basic rules when fitting transducers into standpipes.

BLANKING: Parameter 6 should always be set at least 150mm longer than the length of the standpipe.

STANDPIPE DIMENSIONS: Should be in accordance with the following table:

<u>Flange size and minimum bore of Standpipe</u>	<u>Maximum length of Standpipe</u>
3" (80mm)	300mm
4" (100mm)	300mm
6" (150mm)	400mm
8" (200mm)	600mm
12" (300mm)	600mm

e.g. Using a 4" flanged transducer would required the standpipe length to be no more than 300mm and Pr.6 set at 450mm minimum.

The inside of the pipe and joint with vessel top must be clean and free of any obstructions, seams or welds.

TWINFLEX AC & TWINFLEX DC PROGRAMMING INSTRUCTIONS AND PARAMETER LISTING

Twinflex is programmed by entering values for each of the following Parameters.

Parameter Definitions

<u>Pr. No</u>	<u>Description</u>	<u>Acceptable Values</u>	<u>Default Value</u>
<u>Pr.1</u>	<u>Number of Channels</u> Note! Changing value will reset Pr.2 - Pr.8 to default	1 - 1 Channel 2 - 1 Channels	1
<u>Pr.2</u>	<u>Application</u> Selected value will apply to both channels Note! Changing value will reset Pr.3 - Pr.8 to default	1 - Level 2 - Distance	1
<u>Pr.3</u>	<u>Display Units</u> Selected units will apply to both channels Note! Changing units will reset Pr.4 - Pr.8 to default (metres to the equivalent feet & vice versa)	1 - Metres 2 - % Metres 3 - Feet 4 - % Feet	1
<u>Pr.4</u>	<u>Empty Distance</u> From transducer face to zero level or furthest distance	RZ transducer - 6m max RX transducer - 10m max	6.000 6.000
<u>Pr.5</u>	<u>Span</u> The distance between the furthest and nearest points of measurement for the 4-20mA output(s)	RZ transducer - 6m max RX transducer - 10m max	6.000 6.000
<u>Pr.6</u>	<u>Blanking Distance</u> The minimum distance from the transducer face to the target, within which no valid echoes are processed	RZ transducer - 0.3m RX transducer - 0.4m	0.500
<u>Pr.7</u>	<u>Rate of Change</u> This value should be as low as possible but higher than the maximum rate-of-change of level or distance	0.1 9.999m/min	1.000
<u>Pr.8</u>	<u>Analogue Output Failsafe</u>	1 - Low (0.0mA) 2 - High (22mA) 3 - Hold last reading	3

Note:- Calibration is in measurement units selected in Pr.3 even when percent is selected for the display.

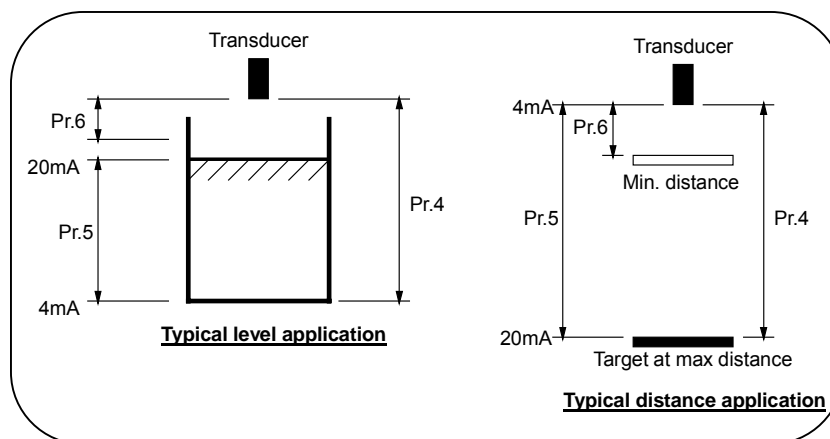

Loss Of Echo Failsafe

If the instrument loses signal for any reason the green echo light will go off after 10secs. The instrument will continue to display the last valid level or distance obtained, for a period of 2 minutes, whilst the search for a valid echo continues. If no echo is found after 2 minutes the instrument will display LOST.

The analogue mA outputs can be designated for failsafe condition; refer to Pr. 8

The 2 channels are completely independent in loss-of-echo conditions.

PROGRAMMING INSTRUCTIONS FOR TWINFLEX

Overview

Parameters are displayed and programmed using the 5 keys shown below which are accessed by removing the transceiver front cover.

DO NOT REMOVE THE TERMINAL PROTECTION COVERS WHILST PROGRAMMING, YOU MAY EXPOSE LIVE CONDUCTORS.

For single channel applications use Ch.1 (LH channel).

Pr.1 is used to select single-channel or two-channel operation.

Pr.2 & Pr.3 selections for Ch.1 are automatically applied also to Ch.2.

To programme Ch.1 only, use Pr.1 - Pr.8 displayed on LH LCD, then enter "RUN" mode.

To programme both channels, use Pr.1 - Pr.8 as above then continue via the ▲ key to programme Pr.4 - Pr.8 displayed on RH LCD.

These can be identical to or different from Ch.1 values.

Key Definition

M = Mode Key - to go from "RUN" to "Prog" Mode
- or to go from Parameter Number to Parameter Value

E/R = ENTER/RUN - to enter a value change
- or to return from "Prog" to "RUN" Mode.

↑ = Increase a Parameter No. or Value
← = Moves cursor Left
→ = Moves cursor right

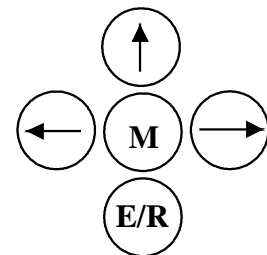

1) To Enter Programme

Press **M** - Display will show "Prog" in LH LCD
Press ↑ immediately - Display will show "Pr.1" and its value alternately in LH LCD

2) To Select a Parameter Number or to view the Values in each Parameter

Continue to press ↑ - Display will progress from Pr.1 to Pr. 8 with each press. Pause after each press to read the Pr. value.

3) To Change the value of a selected Parameter

- Press M again - Display will now show only the value of the selected Pr. number and a cursor will flash in place of the first digit.
- Press ↑ - To increase value of flashing digit between 0 and its max. It will then roll over to its minimum and start again.
- Press → - To move the cursor right and select the next digit to be changed, then press ↑ to change its value as above.
- Press ← - To move the cursor to the left and then press ↑ to change its value as above.
- Press E/R - To enter the new value. The display will then show the Pr. Number and the new value alternately.

4) To Select another Pr. and change its value

- Press ↑ - Proceed as 2 and 3 above.

5) To Complete Programming for Ch.1 and return to RUN mode

- Press E/R - The display will show "0.000" and then the measured value in the selected units after a few seconds.

OR

6) To Continue Programming for Ch.2

- Press ↑ - The display will show "Pr.4" in the RH LCD.
Continue programming Ch.2, Pr.4 - Pr.8 as for Ch.1

7) To Complete Programming for Ch.1 & Ch.2 and return to RUN mode

- Press E/R - The display will show "0.000" and then the measured values in the selected units after a few seconds.

8) To Reset all Parameters to Factory Default (Both channels simultaneously)

- Press M - Displays "Prog".
- Press ↑ immediately - To Display Pr.1
- Press both ← and → simultaneously to display "PrES" and then "Pr.1"

9) Alternative Key Functions

The 4 outer keys have secondary functions which can be viewed without interrupting the instrument's operation. The descriptions assume that both channels are programmed; if only Ch.1 is used there will be no display in the RH LCD.

In the normal "RUN" mode:-

- Press ↑ - Display will show "dEG.C" in LH LCD, then the operating temperatures in both LCDs. If temperature compensation is not used these will be fixed at 20C, otherwise they will be the current ambient temperatures.

- Press → - Display will show "GAIN" in LH LCD, then a number from 0.-100 in both LCDs. This represents the strength of the echoes. Low numbers mean good echoes.

- Press E/R - Display will show "dISt" in LH lcd, then the measured distances from the transducer faces regardless of whether programming is for distance, level or percent.

- Press ← - Display will show "AnA" in LH LCD, then the mA outputs in both LCDs, which are appearing at the relevant terminals.

TWINFLEX AC & DC
SPECIFICATION

Measurement	: Level or Distance (or Percent)
Range	: RZ series transducer - 6m maximum RX series transducer - 10m maximum
Blanking	: 0.5m - adjustable (min 0.3m)
Rate of Change	: 0.1 - 9999m/min
Transducers	: RZV15 or RZT15 (integral temp. sensor) RXV15 or RXT15 (integral temp. sensor) PTFE facing / flanged options All models can be mixed on the same Twinflex
Accuracy of change in level	: 0.25% of measured distance at 20°C
Resolution of analogue	: 2mm or 0.1% of empty distance whichever i
Output	is the greater
Power Supply -AC Model :	110 or 230Vac +/- 10% 50/60Hz 6VA or 21.6 - 30Vdc 5W Manual selection of all voltages
Power Supply-DC Model :	21.6 - 30Vdc 5W only
Analogue Output	: 4-20mA into 750 ohms, 16 bit, short-circuit protected. Non-isolated -ve to ground Fixed to span Pr.5
Ambient Temperature	: -40 to +70°C
Indication	: 4 digit 12mm LCD for each channel Green led for echo status for each channel
Key Functions	: 5 Push Buttons M - Prog / Display ↑ - Increase Pr. or digit ← - Move cursor left → - Move cursor right E/R - Enter / Run

Approvals

: CE Compliant to EN50081-1& EN50082-2
RZ & RX series transducers certified
EEx m II T6 for Zones 1 & 2
Temperature Range -20C to + 60C