

SONOCONTROL 20

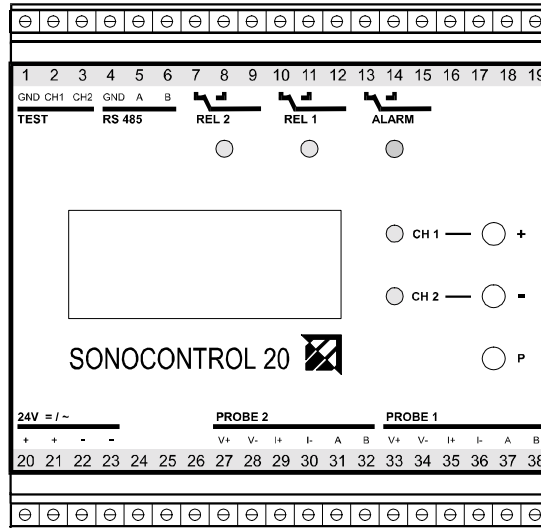

User's Manual

Closing date: 11/99

Document No.: 50/11/04/11/99E

SONOCONTROL 20

Universal Level Limit Switch for Liquids

Table of contents

	Page
1 Safety alerts and other symbols used	4
2 Safety instructions	5
3 Introduction	7
3.1 Overview	7
3.2 Systems components	8
3.3 Measuring methods	9
3.3.1 <i>Pulse-echo method with lateral sensor attachment</i>	10
3.3.2 <i>Pulse-echo method with vertical sensor attachment</i>	11
3.3.3 <i>Ultrasonic transmission</i>	12
3.3.4 <i>Dying down</i>	13
4 Installation	14
4.1 Sensor	14
4.2 SONOCONTROL 20	18
4.3 Connections	18
4.3.1 <i>Connecting the ultrasonic sensors</i>	18
4.3.2 <i>Connecting the SONOCONTROL 20</i>	19
5 Start-up	23
5.1 Installation and wiring check	23
5.2 SONOCONTROL 20 operating modes	23
5.3 Functions of buttons	23
5.4 SONOCONTROL 20 parameter setting	24
5.5 Measured value acquisition	25
5.6 Measured value processing	30
6 SONOCONTROL 20 parameters	31
6.1 Parameter P 02: Channel selection	32
6.2 Parameter P 03: Transmission energy	32
6.3 Parameter P 04: Gain	32
6.4 Parameter P 05 / P 06: Gate beginning / gate width	33
6.5 Parameter P 07 / P 08: Integration Up / Down	34
6.6 Parameter P 09: Hold time	34
6.7 Parameter P 10: Switched output	35
6.8 Parameter P 11: Configuration of switched output	35
6.9 Parameter P 12: Configuration of alarm switched output	36
6.10 Parameter P 90: Device address	36
6.11 Parameter P 92: Software version	37
6.12 Function P 98: Copying parameter sets	37
6.13 Function P 99: Saving parameters	37

7	Advanced Programming mode.....	38
7.1	Parameter P 13: Adjusting the control current for sensor	38
7.2	Parameter P 14: Display panel output.....	39
7.3	Parameter P 15: 2 nd channel configuration	39
7.4	Parameter P 70: Enable / interval for sensor contact verification	39
7.5	Parameter P 71: Transmission energy for sensor contact verification	40
7.6	Parameter P 72: Gain for sensor contact verification.....	40
7.7	Parameter P 73 / P 74: Gate beginning / gate width for sensor contact verification.....	40
7.8	Parameter P 91: Asynchronous cycle rate	41
8	Serial port	42
8.1	Hardware specification	42
8.2	Log	43
8.3	Set of instructions for serial port.....	44
9	Troubleshooting	50
9.1	Troubleshooting.....	50
9.2	Device faults.....	50
9.3	Warnings	52
10	Default settings.....	53
11	Technical data.....	54

1 Safety alerts and other symbols used



This safety alert symbol indicates an immediate hazardous situation. If not avoided it will result in serious injury or **damage to the equipment!** When you see this symbol, do not use the equipment further unless you have fully understood the nature of the hazard and have taken the required precautions.



This alert symbol indicates a potential hazard to the operation of the equipment. When you see this symbol, follow the prompts in this User's Manual to avoid the hazard. Call our service team if necessary.



This symbol indicates that you should call our **service team**.



This symbol indicates a **note** or detailed setting **tips**.



This symbol indicates enumeration.



Operator keys are printed in bold type and placed in pointed brackets.



Display text uses a special font on a grey background.

Symbol decals on the measuring system



This symbol indicates a general hazard. Caution! Follow the documentation. See chapters 4.3 and 4.3.2!



This symbol indicates the operational earthing
See chapter 4.3.1.

2 Safety instructions

The SONOCONTROL 20 and the ultrasonic sensors of the AE series conform to the rules of the trade and comply with all applicable safety regulations.

The producer has taken every precaution to ensure safe working of the equipment. The user must take care that the equipment is set up and installed so that its safe use is not affected.

The equipment has been tested at the producer's works and is delivered in safe operating state.

This User's Manual contains information and warnings which must be complied with by the user to ensure the safe operation of the equipment.



The following safety instructions must be followed before starting the equipment and while using it:

- The equipment must only be started by authorised personnel and operated by instructed persons. All persons using the equipment must have read this User's Manual.
- Only the repair and maintenance operations described in the User's manual must be carried out and only specified parts must be used.
- Service work must only be carried out by the authorised service personnel of **SONOTEC Ultraschallsensorik Halle GmbH**.
- The equipment and all tools used for service or maintenance as well as all other equipment must be earthed as prescribed.
- The protective conductors must be continuous and not broken.
- The SONOCONTROL 20 must only be used in the specified temperature range from -20 to +70°C, the sensor in the temperature range from -20 to +80°C. Otherwise the equipment may not function properly and supply inaccurate results.
- The temperature resistance of the connecting cable must be adapted to the operating temperature of the measuring system.
- The casing of SONOCONTROL 20 and that of the sensor must remain closed when the equipment is in use.
- **Pull all plug connectors on the equipment before opening a housing.**
- All connections, in particular switched outputs, must be made with the supplied screw terminals. All terminal screws, including those on terminals not in use, must be tightened (touch guard/safe from finger-touch).
- The SONOCONTROL 20 must only be supplied with voltage from a source with a mains breaker.
- The owner must make certain that the current on switched outputs does not exceed the rated limit of 5 amps. This can be ensured, for example, by a fusible link.
- The SONOCONTROL 20 must not be exposed to liquid.
- The cable between the SONOCONTROL 20 and the sensor must be shielded. The shield must be earthed at both ends.
- The sensors should be handled with care and screwed in only hand tight. If they are tightened fully, the contact face may be damaged. The sensor housing itself acts as a lever.

- Avoid electrostatic charge.

To prevent injury and damage to the equipment, follow the producer's instructions regarding starting and using the equipment, and maintenance. Maintenance and repairs not described in this User's Manual must only be carried out by authorised personnel.

The firm SONOTEC Ultraschallsensorik Halle GmbH is not liable for damage to a third party occasioned by using the equipment contrary to instructions.

Maintenance, opening the equipment

The SONOCONTROL 20 and the sensor require no maintenance.

Opening the sensor housing is only necessary for installation. Interrupt the voltage supply before opening the housing. The sensor does not contain wearing parts.

*Service note:
Replace the fuse*



It may be necessary to open the housing of the SONOCONTROL 20 to replace the fuse. Pull all plugs before opening the housing. The voltage feed line (terminals 20-24) and the sensor feed (terminals 33/34 and 27/28, respectively) have fusible links. These fuses must only be replaced by authorised service personnel. If a fuse blows, the cause must be identified.

Use type TE-5 fuse as a replacement:

- Install a 630 mA T fuse in the voltage supply line,
- Install a 125 mA T fuse in the line feeding the sensors.

Use only fuses of the specified rating.

Do not use a fuse of higher rating or jumper a fuse.

3 Introduction

3.1 Overview

Level limit switches of the SONOCONTROL series, in connection with ultrasonic sensors, are used for universal level limit detection in systems carrying liquid. The measuring system features a number of benefits:

- The ultrasonic sensors are attached to the outside of the vessel; they are not in exposed to the liquid in the tank.
- As measurement is made from outside, the liquid can be pressurised or be chemically toxic or aggressive. This has no effect on the measured data.
- The measuring method is particularly suitable for application in the pharmaceutical and the food industries.
- Foam on the liquid does not affect the accuracy of the measurement.
- The system can easily be fitted to existing vessels without expensive testing if the vessel is a pressure vessel.

The SONOCONTROL 20 is of universal application:

- Level monitoring of tanks
- Dry-running protection of pumps
- Detection of gas bubbles in liquids
- Level monitoring in pressure bottles
- Dosing control
- Inspection of pipeline pig systems
- Ice level alarm on ice silos.

The SONOCONTROL 20 level limit switch has many functions and supports the use of complex instrumentation systems:

- A microcontroller ensures high measuring accuracy and data integrity.
- The parameters required for installation can comfortably be input via buttons. The parameter inputs are not lost if the power supply is interrupted.
- A serial port supports data exchange with a computer. All parameters can be set and measured values obtained at this port. The port has bus capacity and supports the parallel connection of up to 32 series SONOCONTROL 20 / 21 and SONOMETER 30 / 31 units.
- The SONOCONTROL 20 is available as a single-channel or two-channel version. The second channel permits the independent monitoring of a second limit level or measurement by ultrasonic transmission (see chapter 3.3.3).
- As a rule, the SONOCONTROL 20 is located in the control room. The distance to the sensor on the vessel can be up to 300 metres.

3.2 Systems components

The SONOCONTROL system consists of the following components:

- SONOCONTROL 20 evaluator
- one or two ultrasonic sensors of AE series
- fixing bracket on the vessel
- connecting cable between sensor and evaluator.

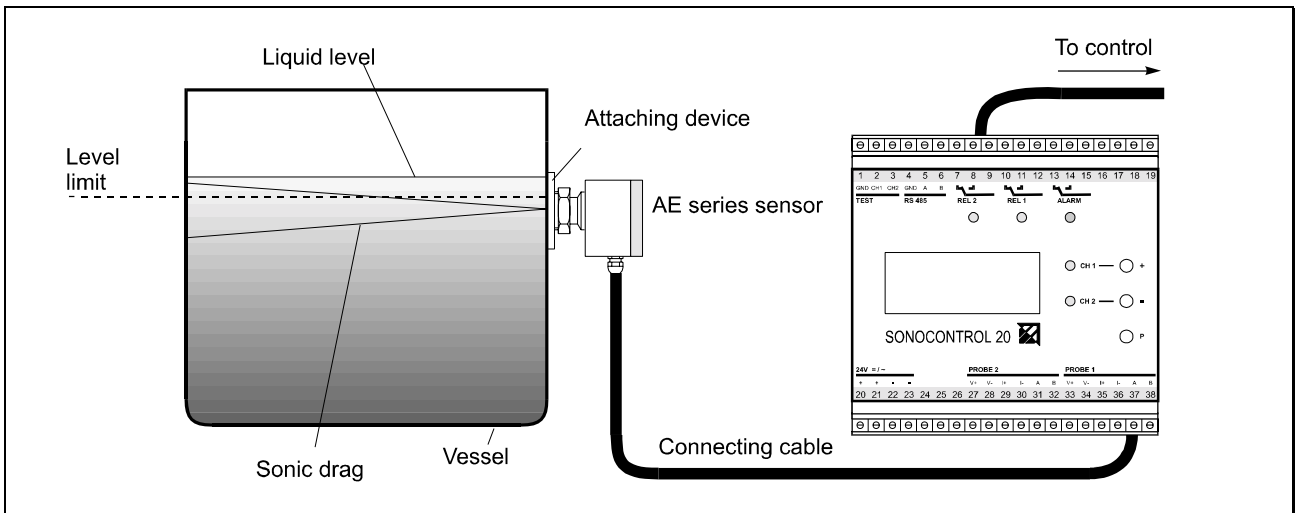

Figure 1: Overview of measuring system components

The selection of the suitable ultrasonic sensor and the appropriate bracket depends on

- the geometrical shape of the vessel,
- the material of which the vessel is made,
- the nature of the monitored liquid.

Our Service staff will be glad to assist you in choosing the most suitable sensors and brackets.

The following types are currently in the market:

Sensor designation	Measuring frequency	Attachment to vessel
AE01, Specification 01	1 MHz	Screw-on module
AE01, Specification 05	1 MHz	Screw-thread M30x1.55
AE20, Specification 01	500 kHz	Screw-on module
AE20, Specification 05	500 kHz	Screw-on thread M45x1.5

Table 1: Overview of available sensors for SONOCONTROL 20

3.3 Measuring methods

The controller operates on the echo time principle. The transmitter emits a brief pulse through an ultrasonic transducer. This pulse penetrates the wall of the vessel, enters and propagates in the liquid. Depending on the measuring method, the reflected ultrasonic signals are received as echo by the same sensor or the ultrasonic signals are picked up by a separate sensor on the other side of the vessel.

After triggering, the received pulses are referenced to a time window (gate) and the result is output. A microcontroller takes over all control functions.

Implemented in the evaluation software is an integration algorithm together with a threshold value. This effectively suppresses all faults. Besides, intolerable jitter of the switched output can be prevented by a programmed hold time.

The controller supports several operating modes:

- pulse-echo mode with one sensor,
- ultrasonic transmission with two sensors,
- dying down with one sensor.

These measuring methods are described with reference to four typical applications on the following pages.

3.3.1 Pulse-echo method with lateral sensor attachment

An ultrasonic sensor is attached laterally at monitored level to the outside of the vessel. It sends a brief ultrasonic pulse through the wall of the vessel.

If the vessel is filled with liquid to the monitored level, the pulse travels through the liquid, is reflected by the opposite wall of the vessel and the sensor picks it up as echo. If no liquid is present at this level, there is no echo.

The presence or absence of echo at the expected point is evaluated by the link-up with the time window (gate) and output as a signal.

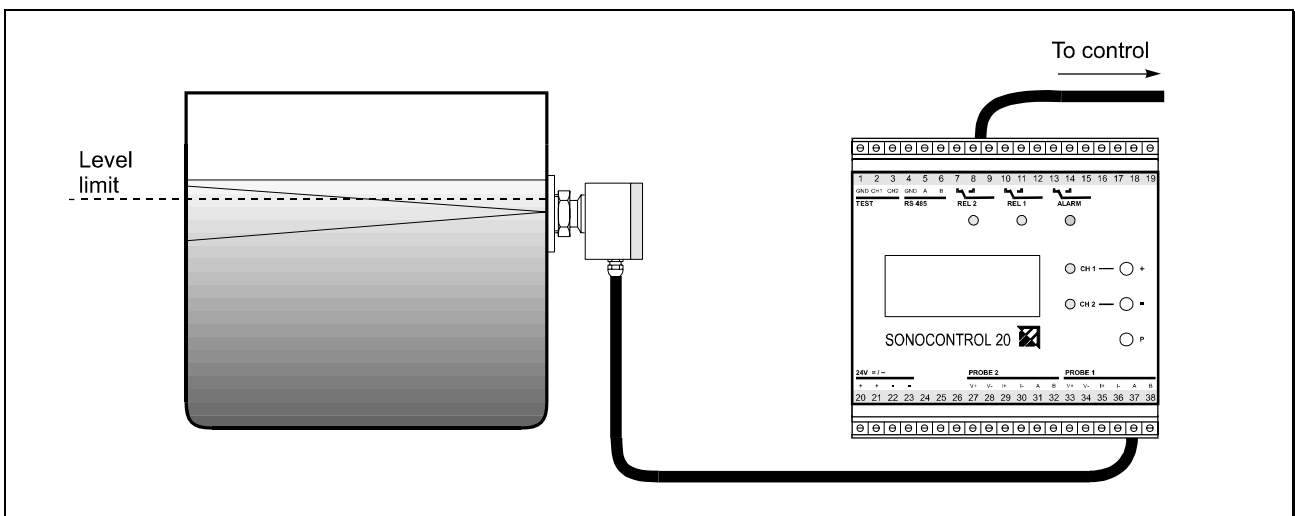

Figure 2:
Pulse-echo method with
lateral sensor attachment

Uses:

- Vessels whose walls are parallel with each other, or pipes (reflection at the rear wall)
Metal, glass: diameter from approx. 200 mm to max. 10 m
Plastic material: diameter from approx. 50 mm to max. 10 m
- No agitator or other internal fittings at monitored level
- Low-absorbing liquids, free of bubbles and solids
- Ice level monitoring in ice silos of flake ice makers in refrigeration systems
- Pig detection in pipelines carrying liquids

3.3.2 Pulse-echo method with vertical sensor attachment

The ultrasonic sensor is attached externally on the underside of the vessel so that the ultrasonic pulse is directed vertically upward (max 2-3° off the vertical line are tolerated).

The pulse is reflected at the surface of the liquid and returns to the sensor. The gate setting is now conveniently used to set the monitored filling level. The temperature drift of the velocity of sound and the time needed for the sonar pulse to return as echo must be observed if necessary.

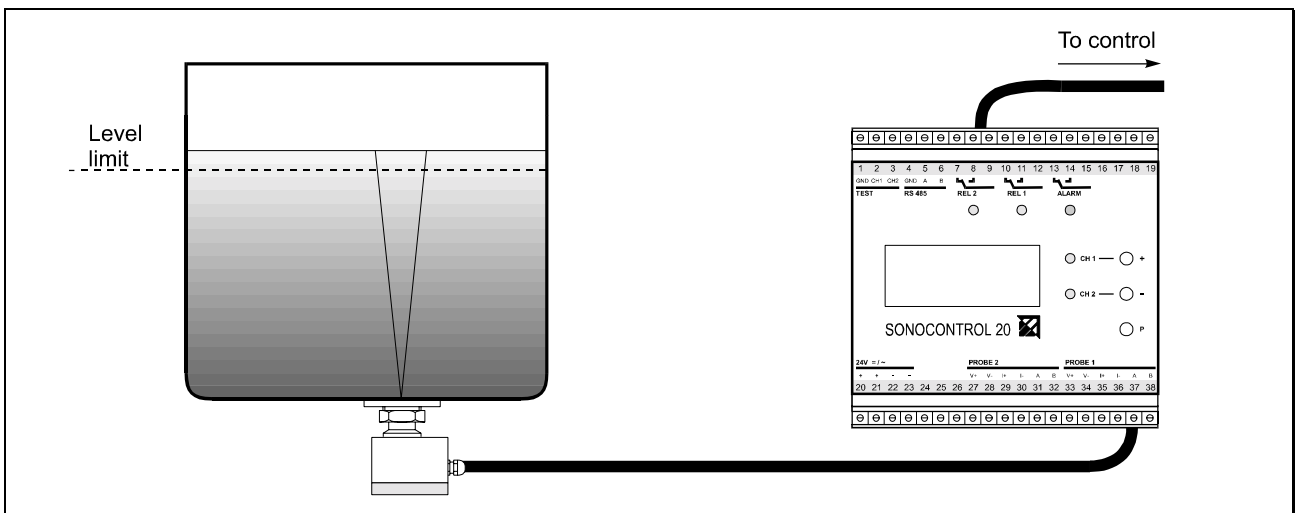

Figure 3: Pulse-echo method with vertical attachment of the sensor

Uses:

- Vessels with filling height from approx. 50 mm to 10 m with horizontal face for attaching the sensor to the bottom of the vessel
- No agitator or other internal fittings in the sound path
- Liquid should be of low, free of bubbles and solids
- Cost-effective solution to substitute continuous level monitoring systems

3.3.3 Ultrasonic transmission

For ultrasonic transmission, two sensors are attached externally to the vessel side at opposite locations. One sensor functions as the transmitter sending out ultrasonic pulses; the other sensor is the receiver picking up the pulse delayed by the time needed in transmission.

This method required a SONOCONTROL 20 of specification 2xx (two-channel equipment). Please note that only measuring channel 1 with switched output is available. Channel 2 works as the transmitter (see chapter 7.3).

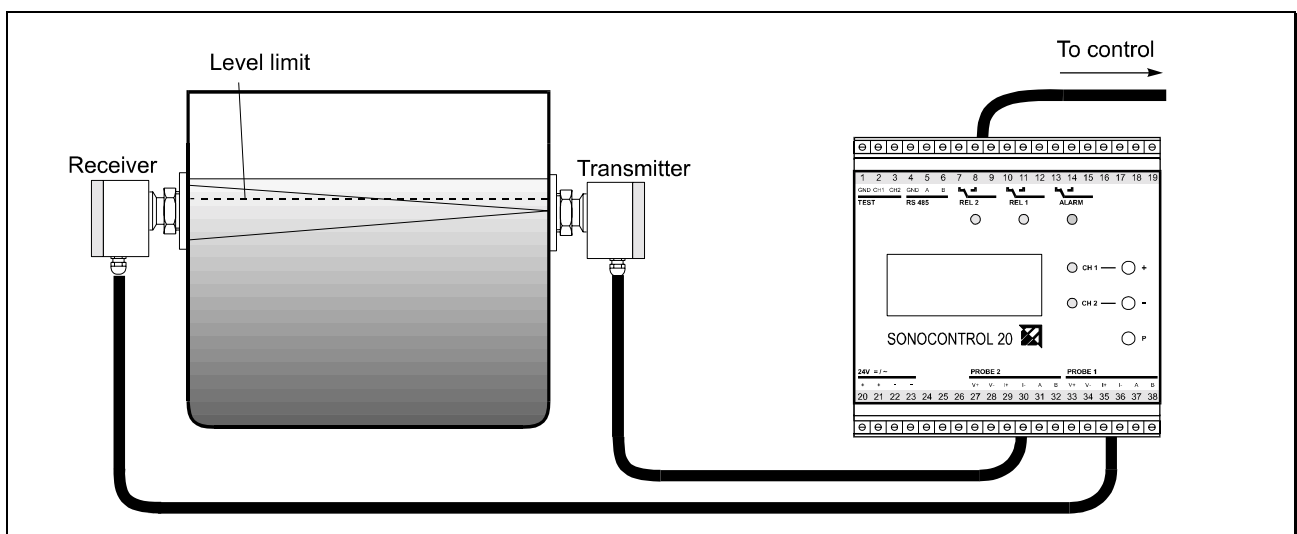

Figure 4: Ultrasonic transmission

Uses:

- Vessels of up to 10 m diameter (sensors aligned to each other)
- Sound-absorbing liquids
- Level monitoring in pipes (with special angle adapters)

3.3.4 Dying down

Dying down involves the evaluation of the decay of the sensor after emitting the ultrasonic pulse and the subsequent reflections in the vessel wall. The sensor is attached externally to the side of the vessel on the same level as the liquid limit.

If no liquid is present at this level, the metal wall is not attenuated and vibrates for a long time under the impact of the ultrasonic pulse. If liquid is present at this level, the vibration decays quicker.

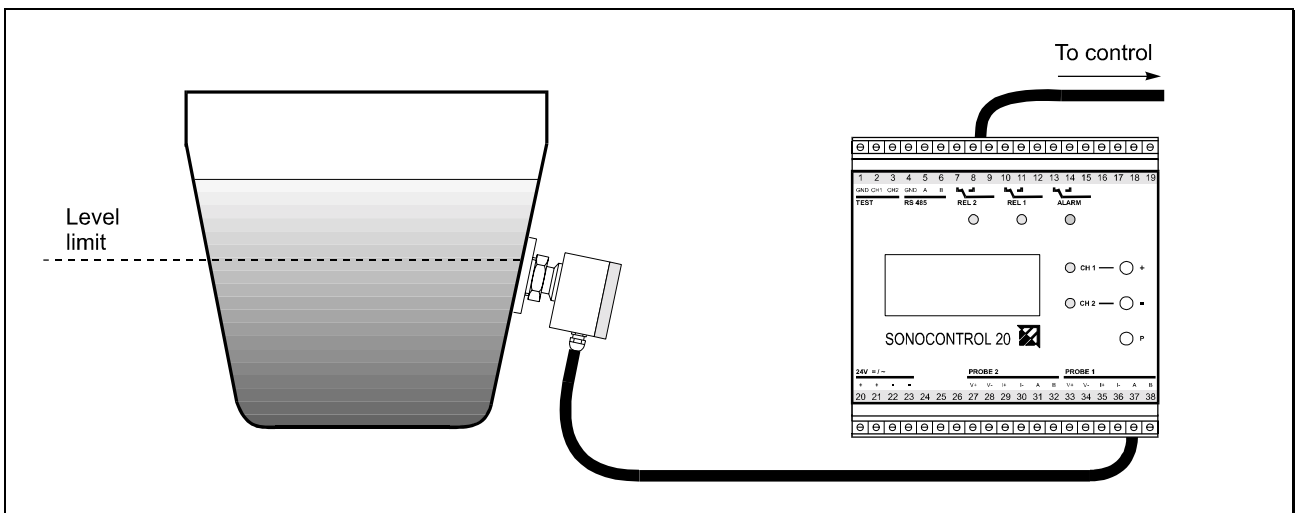

Figure 5: Dying down

Uses:

- Metal vessels with a diameter of 200 mm and over and wall thickness from approx. 2-20 mm
- Sound-absorbing liquids (e.g. with gas bubbles, contaminants)
- The liquid must not leave any residue on the wall of the vessel.
- If the vessel has no reflecting rear wall or has internal fittings
- Wet/dry alarm

4 Installation

4.1 Sensor

Sensor attachment

The sensor can be attached optionally with a screw-type module or thread. As counterpart of the sensor holders the following fixing devices are available:

- Ring for welding or gluing on the vessel,
- Mounting plate for attachment by strap retainers,
- Adapters for special screwed fasteners (Varivent, milk pipe screw connection, clamp closures, etc.).

Illustrations 6 and 7 on the following pages illustrate the various types of sensors and the method of their fixing. Please note that specifications 02 and 06 (these versions have an integrated temperature sensor) are not available for SONOCONTROL 20.

If you are not sure which sensor type is best for your solution, please consult our service personnel, which will be glad to help.

The pulse-echo methods require accurate alignment of the sensor with the sound-reflecting face. For ultrasonic transmission, both sensors must be correctly aligned with each other.

Inspect state of attachment face

State of attachment face

The quality of sound coupling is essential to the sensitivity of the measuring system. Therefore the following points should be noted.

The face to which the sensor is attached on the outside of the vessel must be plane and smooth. Uneven attachment faces (e.g., on glass vessels) make sound contact more difficult and the results may not be correct in some cases. Unevenness of the attachment face can be compensated to some degree by applying a suitable mounting compound. Peak-to-valley height should be <10 µm. Paint or surface treatment are detrimental to good metering results.

There should be no peak or mark (e.g., chisel marks with lateral bulging, or similar). These can damage the sensor when it is installed.

Install mounting compound between sensor and vessel

Install sensor with mounting compound

To ensure good sonar contact, apply a mounting compound between the sensor and the vessel. Use special adhesive if you want a permanent bond.

Apply a finger nail size bead of the adhesive to the tip of the sensor. When The adhesive spreads evenly when the sensor is screwed in or pressed to the attachment face. Mounting compound and special adhesives are available from SONOTEC Ultraschallsensorik.

AE01 / 01

1 MHz / D20mm; without temperature compensation

order no.: 01 41 10 01 01

AE01 / 02

1 MHz / D20mm; with temperature compensation

order no.: 01 41 10 01 02

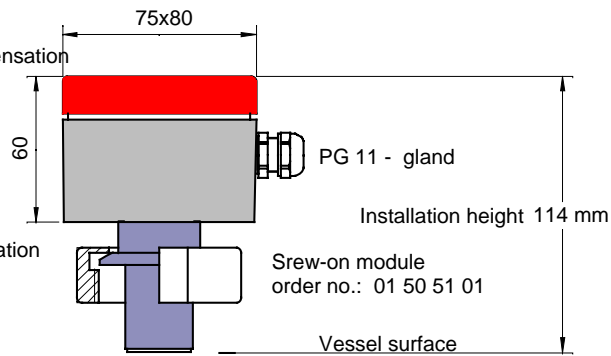

Attachment versions

material : 1.4571

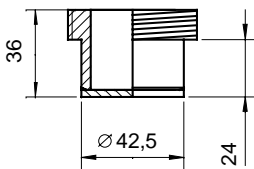

Weld - in ring

order no.: 01 50 51 21 01

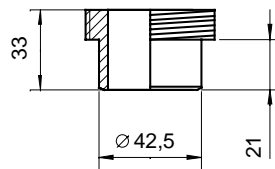

Weld - on ring

order no.: 01 50 51 11 01

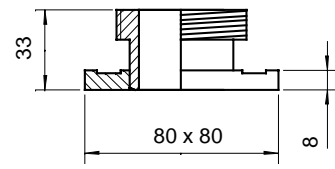

Plate for strap fastener,

weld or glue

order no.: 01 50 52 21 01

AE01 / 05

1 MHz / D20mm; without temperature compensation

M30x1,5
order no.: 01 41 10 01 05

AE01 / 06

1 MHz / D20mm; with temperature compensation

M30x1,5
order no.: 01 41 10 01 06

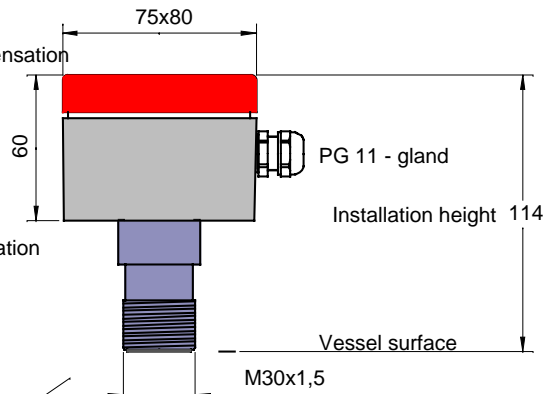

Attachment versions

material : 1.4571

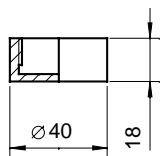

Weld - in ring

order no.: 01 50 01 21 02

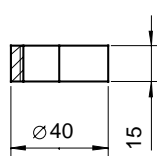

Weld - on ring

order no.: 01 50 01 11 02

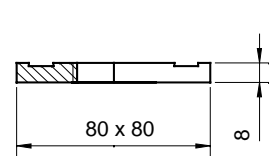

Plate for strap fastener,

weld or glue

order no.: 01 50 02 21 02

Figure 6: Dimensions of series AE01 sensors and attachment versions

AE20 / 01

0,5 MHz / D35mm; without temperature compensation

order no.: 01 41 10 02 01

AE20 / 02

0,5 MHz / D35mm; with temperature compensation

order no.: 01 41 10 02 02

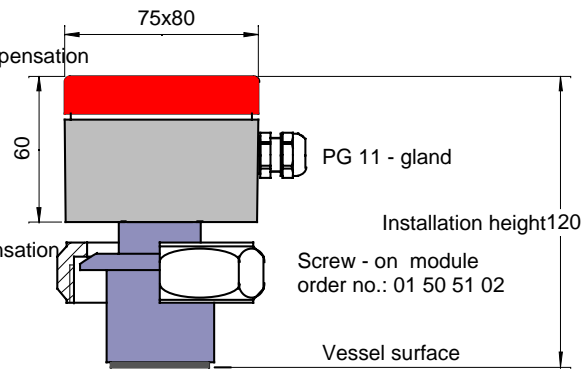

Attachment versions

material : 1.4571

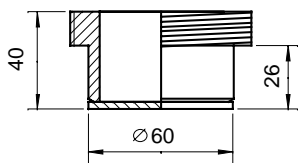

weld - in ring

order no.: 01 50 51 21 02

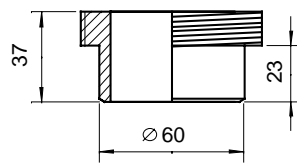

weld - on ring

order no.: 01 50 51 11 02

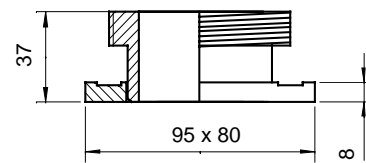

Plate for strap fastener,
weld or glue

order no.: 01 50 52 21 02

AE20 / 05

0,5 MHz / D35mm; without temperature compensation

M45x1,5

order no.: 01 41 10 02 05

AE20 / 06

0,5 MHz / D35mm; with temperature compensation

M45x1,5

order no.: 01 41 10 02 06

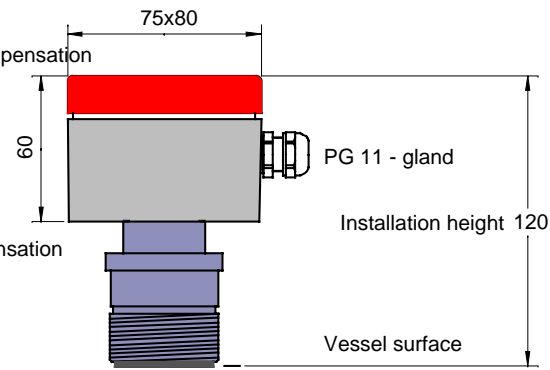

Attachment versions

material : 1.4571

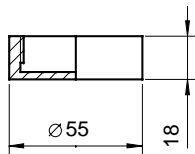

weld - in ring

order no.: 01 50 01 21 03

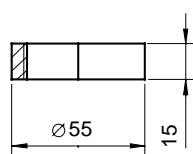

weld - on ring

order no.: 01 50 01 11 03

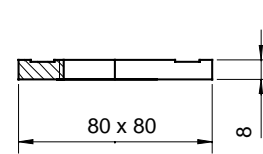

Plate for strap fastener,
weld or glue

order no.: 01 50 02 21 04

Figure 7: Dimensions of series AE20 sensors and attachment versions

*Install sensor only
hand-tight*



If the sensor is attached by means of screw-type module, install the sensor in the receiver and screw the cap hand-tight. The sensor can be aligned to some degree by tightening the cap, i.e., deviation caused during installation of the retainer can be compensated. The direction in which the cable exits can be selected freely by turning the sensor.

If you use a sensor with screw thread, no mechanical adjustment is possible. Like sensor with screw-type module, install the sensor only hand-tight. Note that the front of the ultrasonic transducers are covered with a high-precision plastic coat.

*Operating
temperature*

Operating temperature

The specified maximum operating temperature of the sensors must not be exceeded, not even for a short moment.

The sensor consists of the ultrasonic transducer and the electronic control circuits. The ultrasonic transducer, which has direct contact with the vessel, is designed for a maximum temperature of 135°C. The electronic circuitry in the sensor housing can tolerate temperatures from -20°C to 80°C. Self-heating due to operation remains low (up to 10 K). The permitted ambient temperature range of the sensors is essentially determined by the local conditions, i.e., by the possibility to carry off heat.

Here are two examples:

*Example 1:
Sensor attached to
vessel, no
convection possible*

(1) The sensor is attached to a heated vessel. The vessel is completely covered with heat insulation. As in these conditions heat cannot be transported, the sensor heats to the temperature of the vessel. In this case the maximum vessel temperature is 70°C, viz. the highest permitted temperature of the electronic circuitry less the degree of self-heating.

*Example 2:
Sensor attached to
vessel, with good
convection*

(2) The sensor is used on a vessel without thermal insulation. Convection is not obstructed. In this situation a temperature gradient develops in the sensor, i.e., the temperature of the sensor housing is lower than that of the vessel. The maximum vessel temperature can be 135°C provided the temperature of the electronic circuits remains within the a.m. range. The actual temperature measured depends on a variety of factors and cannot be predicted reliably at this point.



CAUTION: There is risk of burns if the temperature of the sensor housing is above 70°C!

4.2 SONOCONTROL 20

The SONOCONTROL 20 is installed in a control cubicle. It is mounted to a standard 35mm supporting rail.

The SONOCONTROL 20 must be protected from the ingress of moisture. The degree of protection of the housing /the terminals is IP20/ IP00.

The permitted temperature range from 20°C to 70°C must not be exceeded.

4.3 Connections

Device overview

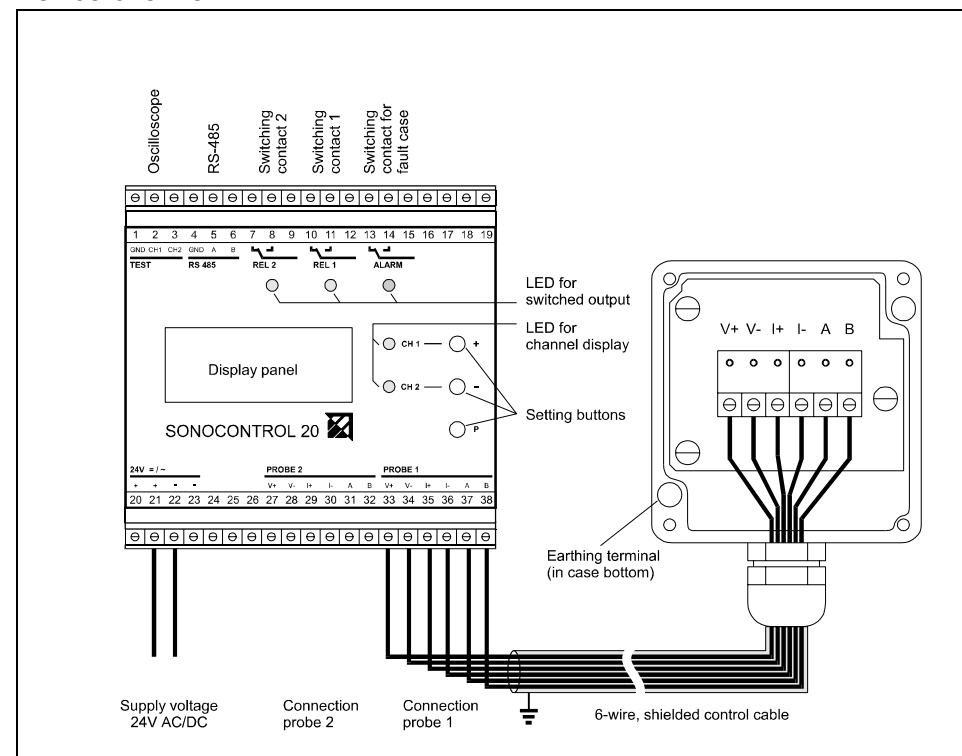

Figure 8: Controls and connections

4.3.1 Connecting the ultrasonic sensors

The ultrasonic sensors of the AE series consist of an ultrasonic transducer and the electronic circuitry. Power is supplied and the electronic circuits controlled by the SONOCONTROL 20.

Connect the sensors to the SONOCONTROL 20 with a 6-wire shielded control cable. We recommend shielded control wire type LiYCY 6x0.5. The cable can be 300 m long. The resistance of each wire must not exceed 10 Ω for the chosen length of cable. This means that conductors of smaller cross section area can be used if the cable length is short. Assuming round wire cross section and outside cable diameter of 5 – 10 mm, the IP65 degree of protection of the sensor is ensured.

Use shielded control cable LiYCY 6x0.5

Attaching the cable to the sensor

The shield is connected to the housing and earthed when the cable is installed in the cable bush. To attached the cable, proceed as follows:

- Open the sensor housing
- Strip approx. 60 mm of the cable
- Unscrew the cap on the cable bush
- Pull out the cable bush insert
- Pull the cable through the cap and the insert
- Terminate six wires with wire end ferrules
- Bend back the shield over the O-ring in the insert, cf. Figure 9

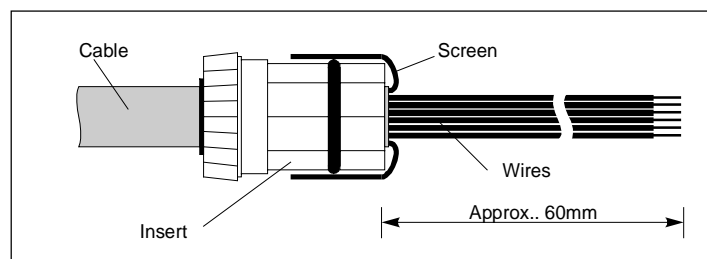

Figure 9: Attaching the cable to the sensor

- Install the wires through the cable bush and fully press in the insert, this causes the shield to be pressed to the inside of the cable bush
- Screw the cap tight, this fixes the cable and makes it insensitive to tensile stress
- Connect the terminals
- Close the housing cover



The installation will be easier if you pull the screw terminals off the electronic circuits when making the connections.

Earth sensor if vessel is not of metal.

On metal vessels, the sensor is earthed by ist housing. If the vessel is made of non-conducting material, you should earth it by means of the earth-terminal screw on the bottom of the sensor housing.

4.3.2 Connecting the SONOCONTROL 20

The connections of the SONOCONTROL 20 to the ultrasonic sensor and the subsequent control are made by screw terminals located on the top and bottom walls of the vessel, see Table 2.



To make installation of the connecting lines easier, the screw terminals can be pulled off.

Top plug connector

Pin	Meaning
1	Ground for oscilloscope
2	Channel 1 test output for visual inspection with oscilloscope
3 *)	Channel 2 test output for visual inspection with oscilloscope
4	Ground for serial interface RS-485
5	A line RS-485 (bi-directional)
6	B line RS-485 (bi-directional)
7 *)	Break contact for switching signal 2
8 *)	Make contact for switching signal 2
9 *)	Common connection for switching signal 2
10	Break contact for switching signal 1
11	Make contact for switching s1
12	Common connection for switching 1
13	Break contact for switching signal in case of fault
14	Make contact for switching signal in case of fault
15	Common connection for switching signal in case of fault
16	Reserved, not to be contacted
17	Reserved, not to be contacted
18	Reserved, not to be contacted
19	Reserved, not to be contacted

Bottom plug connector

Pin	Meaning
20	First pole for 24V AC/DC supply voltage
21	Internal connection with pin 20
22	Second pole for 24V AC/DC supply voltage
23	Internal connection with pin 22
24	Reserved, not to be contacted
25	Reserved, not to be contacted
26	Reserved, not to be contacted
27 *)	Positive operating voltage, sensor 2
28 *)	Negative operating voltage, sensor 2
29 *)	Positive connection for current control loop, sensor 2
30 *)	Negative connection for current control loop, sensor 2
31 *)	A line for sensor 2
32 *)	B line for sensor 2
33	Positive operating voltage, sensor 1
34	Negative operating voltage, sensor 1
35	Positive connection for current control loop, sensor 1
36	Negative connection for current control loop, sensor 21
37	A line for sensor 1
38	B line for sensor 1

Table 2: Terminal pin configuration

Connections marked with an asterisk (*) are only available if your SONOCONTROL 20 is a 2-channel unit (spec. 2xx).

Attaching the sensor cable to the SONOCONTROL 20

- Where the cable enters the control cabinet, connect the cable shield to the equipotential bonding. Avoid earthing connection by a long line as this renders the shield ineffective. There is no need to connect a shield to the SONOCONTROL 20.
- Strip the cable and install end ferrules.
- Connect the cable from the cable to the terminals of SONOCONTROL 20 as shown in table 2. This ensures that the terminals V+, V-, I+, I-, A and B on SONOCONTROL 20 are connected to the terminals of the same designation in the sensor.

Operating voltage circuit wiring

The supply voltage poles cannot be mistaken. Make the connections of the operating voltage as follows:

- Terminal 20/21: first pin 24 V AC/DC, max. 500 mA
- Terminal 22/23: second pin 24 V AC/DC, max. 500 mA



Terminals 20 and 21 as well as 22 and 23 are internally wired. A second unit can easily be supplied with operating voltage.



Max. range for supply voltage: 19 ... 30 V AC/DC

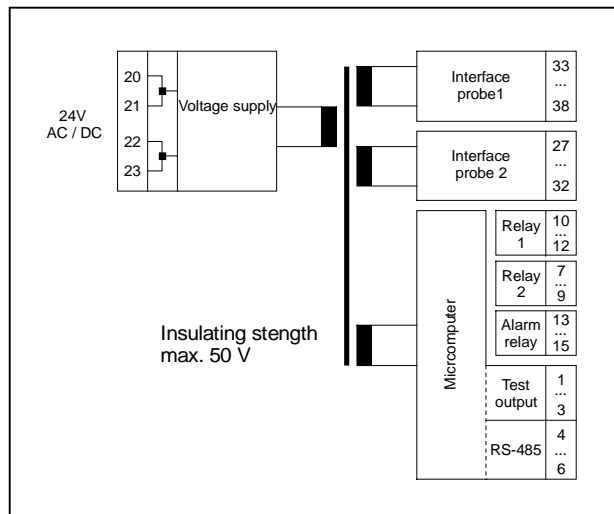

To ensure high resistance to electromagnetic interference (EMI), signals are transmitted differentially. Besides, all function blocks in SONOCONTROL 20 are supplied with electrically isolated operating voltage. This avoids wrong connection due to potential difference.

Figure 10: Galvanic isolation in the SONOCONTROL 20



Please note that the electric isolation of the assemblies is limited to an isolation strength of 50V. **The galvanic isolation must not be used to disconnect the mains supply.** Disconnect the mains supply by means of an externally connected power supply unit. Figure 10 contains an illustration of the assemblies with isolated supply voltage and the appropriate terminal connections.



Protect the unit effectively from transient interference (e.g., lightning).

The SONOCONTROL 20 is ready for operation approximately 3 seconds after starting the operating voltage when the word **run** is shown on the display panel.

Switched output wiring

All switched outputs are designed as relay contacts (changeover contacts), which ensures galvanic isolation from the SONOCONTROL 20. The maximum switching current is 5 A. There is no limitation of the switching current in the SONOCONTROL 20. Suitable external provision should be made by the owner of the unit.

Assignment of switched outputs		
Equipment specification	Measuring channel	Identification on equipment
1xx	1	REL 1
2xx	1	REL 1
	2	REL 2

Table 3: Assignment of switched outputs by equipment specification

Equipment specification	Max. switching voltage/current
xx1 and xx2	50V / 5A
xx3 and higher	250V / 5A

Table 4: Maximum switching voltage by equipment specification

Test output

Connect the oscilloscope to the test output for a visual assessment of the echo pattern. Connect the oscilloscope ($R_E = 1 \text{ M}\Omega$) to the test output with a test head or other suitable measuring line.

The following oscilloscope settings are recommended:

Triggering: AC / negative flank / level: -400 mV

Y co-ordinate: 200 mV/DIV

Time base: 100 μs /DIV ... 5 ms/DIV depending on measuring range

On principle, the following picture will be obtained if the working method is correct:

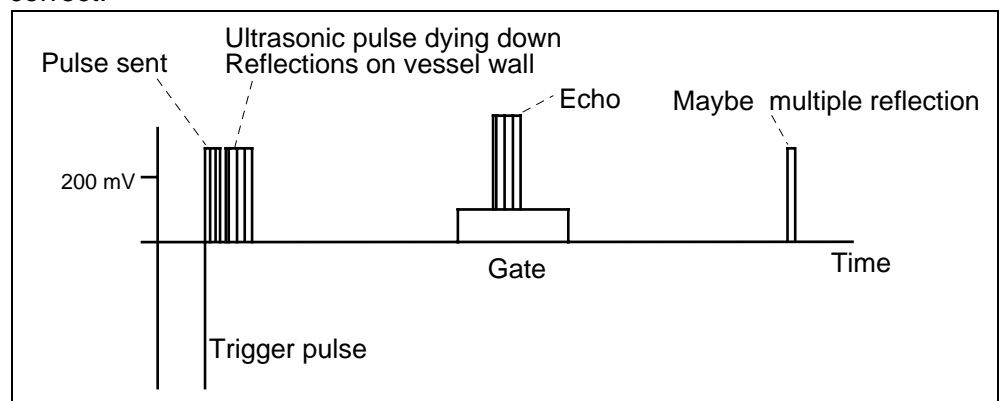

Figure 11: Visual inspection of the test output using an oscilloscope

5 Start-up

5.1 Installation and wiring check

Before feeding operating voltage, make sure of the correct installation of the sensor (firm seating of all fastening elements, the cable attachment and the housing cover).

Inspect the wiring on the sensor, the SONOCONTROL 20 and other units, if any. Ensure, in particular, that all plug-type terminals on the SONOCONTROL 20 are installed at the correct places.

Make sure that the sensor is earthed. If the vessel is made of nonconducting material, a separate earthing cable must be installed. The cable shield of the probe cable must be connected to the equipotential bonding of the control room.

If a power supply unit is used, the installation instructions should be observed.

5.2 SONOCONTROL 20 operating modes

When operating voltage is supplied, the SONOCONTROL 20 is running in regular measuring mode which is identified by the word **run** on the display panel.

In programming mode the parameter settings can be polled and edited. There are two ways to go from measuring mode to programming mode:

1. Programming by means of 3 buttons and the display panel on the front plate of the SONOCONTROL 20.
2. Programming by the serial interface RS-485. During serial communication the word **r 485** is shown on the display panel.

5.3 Functions of buttons

Button functions in measuring mode

There are three buttons in the right-hand part of the front plate. These buttons have the following functions in measuring mode:

- Button **<P>**: Changes to programming mode
- Button **<+>**: Switches the display to measuring channel 1
- Button **<->**: Switches the display to measuring channel 2

Switching from one measuring channel to the other is only possible on 2-channel versions of the SONOCONTROL 20 (specification 2xx).

Button functions in programming mode

In programming mode, the buttons perform a second function:

- Button **<P>**: Selects a parameter, confirms entries
- Button **<+>**: Increments the selected parameter
- Button **<->**: Decrements the selected parameter

5.4 SONOCONTROL 20 parameter setting

1. Starting the programming mode

Enabling the programming mode:
CodE

Pressing button <P> once for about 2 seconds starts the programming mode. The word CodE is shown on the display panel.

Code number input:
0000

Pressing button <P> again causes the code 0000 to be shown on the display panel. This is a prompt for you to input a code number.

Normal programming mode:
0345

The programming mode is divided in two different levels. The selection is made by the input of a code number at the beginning of the programming mode. Press buttons <+> and <-> until you can enter one of the following code numbers:

- Normal programming mode: Enter code number: 0345
On this level you can program all parameters which are important for the start-up of the SONOCONTROL unit.

Advanced programming mode:
1799

- Advanced programming mode: Enter code number: 1799
This level has several functions that are not available to the user in normal programming mode (see chapter 7: Advanced Programming mode). These functions should only be used by instructed persons.

Wrong code number:
End

If you enter a wrong code number, the prompt End is shown on the display panel and the system exits the programming mode.

If the correct code number is entered, press <P> to confirm the entry. The system then goes to the Parameter Selection menu.



Entry of the code number is not necessary if the user exited the previous programming procedure without saving parameters. In this case, pressing button <P> directly starts the programming mode. If you want to re-enable the code number to protect from unauthorised access save the data before exiting the parameter setting function.

Select Parameter menu:

2. Parameter Selection menu

P xx

On the display panel P xx is shown. The number xx indicates the current parameter number.

Parameter display:
xxxx

You can set a parameter number by pressing buttons <+> or <->. The required parameter value is confirmed by a press of button <P> and will be shown on the display panel.

If you select a parameter that has not been implemented or is not available on the current programming level, the system goes to the next possible parameter.

Button <+>:
Increments value

3. Setting a parameter

Button <->:
Decrements value

The parameter value on display can be changed within permitted limits by pressing button <+> or <->. Confirm the new setting by pressing <P> and the system returns to the Parameter Selection menu, (P xx is shown on the display panel); the parameter number indicates the next higher parameter.

Button <P>:
Next parameter

4. Cancelling the programming mode

P 99

Save parameters:

0 No save

1 Save

End
End of
programming
mode

Rapid toggle between:
measuring mode ↔
programming mode

Warning:
Parameter not saved!

F 09

You can select, view or change the parameters in any sequence. The programming mode is cancelled by calling the last parameter, P 99 (Saving parameters, see chapter 6.13). After making and confirming the entry, the programming mode is cancelled. The word End is shown on the display panel and the system returns to the measuring mode.

Please note the following:

- Normally, any entry in programming mode is carried out immediately. The measuring procedure is continued without limitation in the background.
- If the programming mode was cancelled **without saving** the parameter entries, the code-protected **access remains disabled**. In this case pressing button <P> returns you to the programming mode directly. This is a convenient way to toggle between programming mode and measuring method.
- If the programme fails to detect any activity for 16 minutes, it returns to the measuring mode automatically. To remind the user that the parameter entries will not be saved when the program is exited and the code-number protection has not been re-enabled, the code F 09 is shown on the display panel.
- As long as the programming mode remains enabled, communication via the RS485 interface is not possible.



If in programming mode you want to go from one programming level to another programming level, save the parameter entries at first (see chapter 6.13), cancel the programming mode and then start it again by pressing button <P>.

5.5 Measured value acquisition

Before the SONOCONTROL 20 can be used for measurement, it must be adjusted to the concrete conditions (vessel and medium). Two fundamental settings are required for the acquisition of measured values:

Set transmission
energy/ gain

(1) The amplitude of the ultrasonic pulse is attenuated as it propagates through the liquid in the vessel. Hence, the pulse must be electronically amplified when received.



The transmission energy of the ultrasonic pulse and the gain must be set so that the pulse can penetrate the medium and is detected clearly by the receiver.

Set gate

(2) An internal time window is generated in the SONOCONTROL 20. Only ultrasonic pulses received in this time window are recorded for measurement. Pulses received earlier or later will be ignored. The time window is also referred to as „gate“ as it allows the received pulse to „pass“ or „blocks“ it.



The gate should be positioned to ensure that the reflected ultrasonic pulses are received in the prescribed time window.

The further procedure depends on the selected measuring method. Please read on at the point that has been written for your application. The parameter needing change are discussed by way of reference in chapter 6.

Pulse-echo with lateral attachment of probe

(a) Pulse-echo method with lateral attachment of probe

- Connect the oscilloscope to the test output of the appropriate channel.
- Fill the vessel with liquid to above the sensor level.

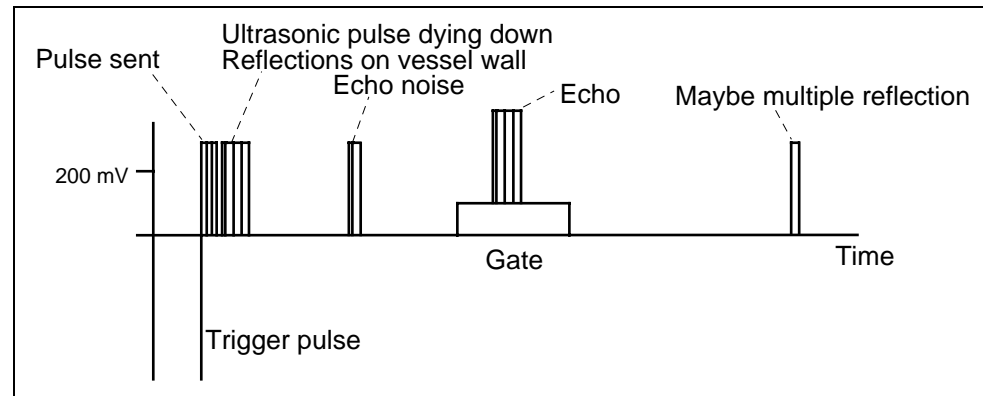

Figure 12: Signal at test output in pulse-echo method with lateral probe attachment

- If no echo pulses can be seen as illustrated in figure 12, increase the transmission energy (P 03) and/or the gain (P 04) until ultrasonic signals are received continually.
- Reduce the level of liquid in the vessel to below the level of the sensor.
- The echo that you received should not be visible any more. If any echoes are received, these represent noise which should remain outside the gate. To identify the „useful echo“, fill the vessel again and proceed as described above.
- Shift the gate by changing the value for the gate beginning (P05). If you decrement the setting, the gate will shift to the left on the oscilloscope, if you increment it, the gate shifts to the right.
- Change the gate width (P 06) to ensure that the detected echo signal is received approximately at gate centre. Noise echoes should be suppressed securely.

Evaluation

- | | |
|------------------------------|-----------------------|
| Ultrasonic signal in gate | ➔ Limit level reached |
| No ultrasonic signal in gate | ➔ Level below limit |

**Pulse-echo method
with vertical
attachment**

(b) Pulse-echo method with vertical attachment of probe

- Connect the oscilloscope to the test output of the appropriate channel.
- Fill the vessel with liquid as exactly as possible to the required limit level.

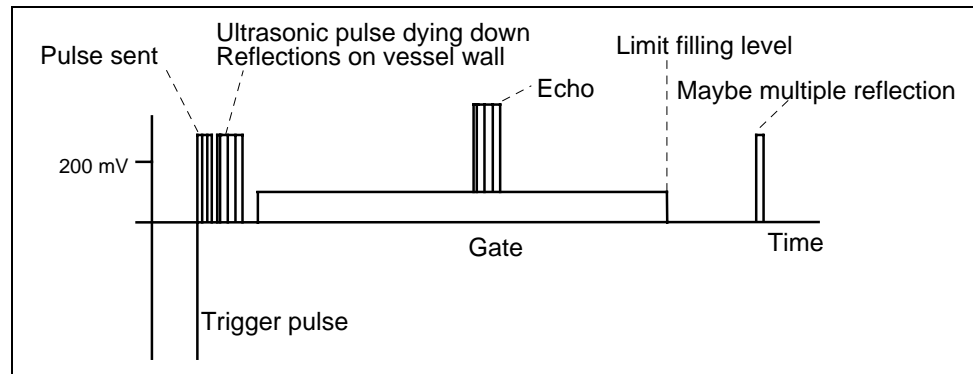

Figure 13: Signal at test output in pulse-echo method with vertical attachment of probe

- If no echo pulses can be seen as illustrated in figure 13, increase the transmission energy (P03) and/or the gain (P04) until ultrasonic signals are received continually.
- Shift the gate beginning to ensure that the dying down of the ultrasonic signal ends before the gate begins. This is done by changing parameter P 05. If you decrement the setting, the gate will shift to the left on the oscilloscope, if you increment it, the gate shifts to the right.
- The gate width (P 06) determines the level limit. If the liquid in the vessel is exactly at the limit level, set the gate width so that the echo is marginally still inside the gate. In any other case, calculate the gate width by means of the equations in chapter 6.4.
- Please note that the transmission time of the ultrasonic pulse and hence the height of the liquid column in the vessel, depend on the medium and its temperature.

Evaluation

- | | |
|------------------------------|-----------------------|
| Ultrasonic signal in gate | ➡ Level below limit |
| No ultrasonic signal in gate | ➡ Level limit reached |

Ultrasonic transmission method

(c) Ultrasonic transmission method

- For this method a 2-channel SONOCONTROL 20 (specification 2xx) is required.
- Connect the oscilloscope to the test output of channel 1.
- Fill the vessel with medium to above the sensor level.
- To adjust the SONOCONTROL 20 for ultrasonic transmission, go the Advanced Programming mode (see chapter 7).
- Change parameter P 15 from 0 to 1 (to enable the ultrasonic transmission mode).

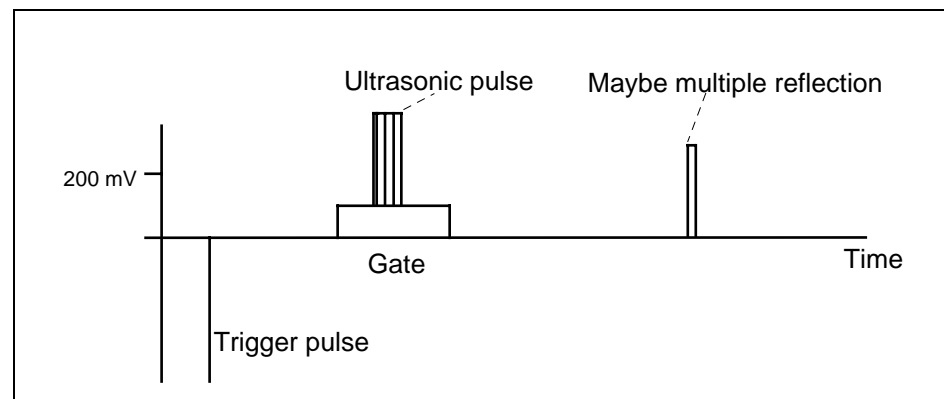

Figure 14: Signal at channel 1 test output with ultrasonic transmission

- If no echo pulses can be seen as illustrated in figure 14, increase the transmission energy (P03) and/or the gain (P04) until ultrasonic signals are received continually.
- Reduce the level of liquid in the vessel to below the level of the sensor.
- The ultrasonic signal that you received should not be visible any more. If any echoes are received, these represent noise which should remain outside the gate. To identify the „useful echo“, fill the vessel again and proceed as described above.
- Shift the gate by changing the value for the gate beginning (P05). If you decrement the setting, the gate will shift to the left on the oscilloscope, if you increment it, the gate shifts to the right.
- Change the gate width (P 06) to ensure that the detected echo signal is received approximately at gate centre. Noise echoes should be suppressed securely.

Evaluation

- | | |
|------------------------------|-----------------------|
| Ultrasonic signal in gate | ➡ Limit level reached |
| No ultrasonic signal in gate | ➡ Level below limit |

Dying down**(d) Dying down**

- Connect the oscilloscope to the test output of the appropriate channel.
- Fill the vessel with medium to above the sensor level and observe the dying down of the transmitted pulse.

Figure 15: Signal at test output with dying down **with no liquid at limit level**

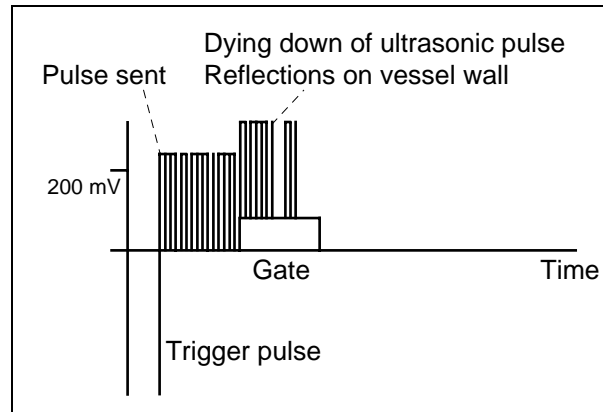
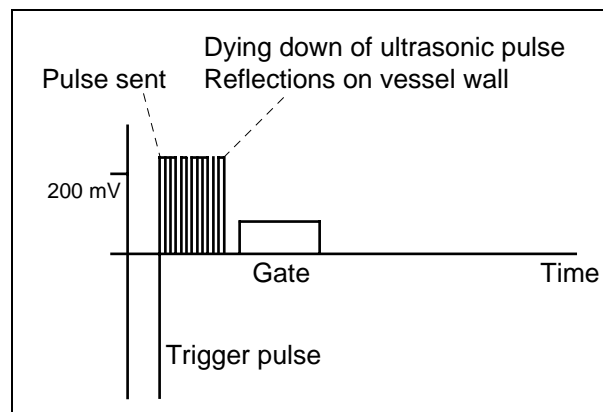

Figure 16: Signal at test output with dying down **with liquid at limit level**



- If no echo pulses can be seen as illustrated in figure 15 and figure 16, increase the transmission energy (P03) and/or the gain (P04) until ultrasonic signals are received continually.
- Shift the gate beginning to ensure that the dying down of the ultrasonic signal ends before the gate begins. If you decrement the setting, the gate will shift to the left on the oscilloscope, if you increment it, the gate shifts to the right.
- Reduce the liquid level in the vessel to below sensor level.
- Make certain that the dying down of the ultrasonic pulse does enter the gate.
- Set the gate width (P 06) to ensure that it completely embraces the dying down of the ultrasonic pulse.

Evaluation

- | | |
|------------------------------|-----------------------|
| Ultrasonic signal in gate | ➡ Level below limit |
| No ultrasonic signal in gate | ➡ Level limit reached |

5.6 Measured value processing

After setting the echo detection the SONOCONTROL 20 is adjusted to your process conditions.

Response time, smoothing

- Parameters P 07 „Integration Time Up“ and P 08 „Integration Time Down“ control the response time of the SONOCONTROL 20. This permits to smoothen the result.

Switched output hold time

- At least the „Hold Time“ set with parameter P 09 must elapse between any two switching operations of a switched output.

Inverted switching function, assignment of switched outputs

- The behaviour of the switched outputs on detection of an echo and the channel assignment of the alarm switched output are determined by parameters P 10 to P 12.

Device address

- If the serial port of the SONOCONTROL 20 is used, you should assign a device address with parameter P 90.

Copy parameters to the other channel

- If you are using a 2-channel SONOCONTROL 20 (specification 2xx) in which both sensors perform similar measuring tasks, you can enable a copy function with parameter P 98 and copy all parameters from the current channel to the other channel.

Save parameters

- The entered parameters are permanently saved with parameter P 99.

6 SONOCONTROL 20 parameters

Param. No.	Spec. 1xx	Spec. 2xx	Designation	Settings
CODE	x	x	Programming mode access code	0345
P 02		x	Channel selection	CH1 / CH2
P 03	x	x	Transmission energy	Step 1 ... 9
P 04	x	x	Gain	Step 1 ... 67
P 05	x	x	Gate beginning	0.001 ... 30 ms
P 06	x	x	Gate width	0.001 ... 30 ms
P 07	x	x	Integration up	OFF, 0.1 ... 500 s
P 08	x	x	Integration down	OFF, 0.1 ... 500 s
P 09	x	x	Hold time	0.1 ... 2000 s
P 10	x	x	Switched output	0: relay closed on echo, 1: inverted
P 11	x	x	Relay	OFF / On / auto
P 12	x	x	Alarm relay	OFF / On / auto (auto CH1 / CH2 / CH1+CH2)
P 90	x	x	RS485 device address	1 ... 32
P 92	x	x	Software version	yyxx: read only
P 98		x	Copy parameters	0: no copy / 1: copy parameters
P 99	x	x	Save parameters	0: no save / 1: save permanently

Table 5: Parameter overview

6.1 Parameter P 02: Channel selection

This parameter is only available in devices with two measuring channels (specification: 2xx).

This parameter selects the measuring channel in programming mode. All further entries of parameters relate to the channel selected here. The green LED for CH1 and CH2, respectively, lights to indicated the selected channel.

Button <+>: Channel 1

CH 1

- Switching to channel 1: <+> ⇒ **CH 1** ⇒ <P>, green LED CH1 lights

Button <->: Channel 2

CH 2



- Switching to channel 2: <-> ⇒ **CH 2** ⇒ <P>, green LED CH2 lights

The channel can also be selected in measuring mode before starting the programming mode.

6.2 Parameter P 03: Transmission energy

Settings

0001 ... **0009**: Transmission energy steps

This parameter specifies the energy content of the emitted ultrasonic pulse. The higher the transmission energy, the higher the energy content of the emitted ultrasonic pulse.

6.3 Parameter P 04: Gain

Settings

0001 ... **0067**: Gain steps

The electronic circuitry amplifies the reflected ultrasonic pulse (echo) and then converts it into a digital signal (triggering). This parameter sets the strength of gain.

The setting should preferably made with visual inspection by an oscilloscope connected to the test output (see chapter 4.3.2).

If echo signals are detected, a little arrow appears in the top left corner of the display panel.



One step changes the gain power approximately by 1 dB. The unit dB is a logarithmic, relative unit of measurement. For example, 20 dB are equal to factor 10; 6 dB to factor 2.

6.4 Parameter P 05 / P 06: Gate beginning / gate width

Settings



0.001 ... 30.00: Gate beginning / Gate width in [ms]

The sum of gate beginning and gate width must not be greater than 32.00 ms. The gate width may be limited by the SONOCONTROL 20.

The parameters P 05 and P 06 set the gate as required by the transmission time of the ultrasonic pulse.

Generally, the following equation applies:

$$T_{\text{Signal}} [\text{ms}] \approx \frac{L_{\text{Weg}} [\text{mm}]}{v_l [\text{m/s}]}$$

T_{Signal} : Transmission time of the ultrasonic signal
 L_{Distance} : Distance travelled by the ultrasonic signal
 v_l : Speed of sound in liquid

Equation 1: Ultrasonic signal transmission time



Table 6 contains the sound speeds of selected liquids at 20°C temperature. The speed of sound depends a little on temperature. If you are in doubt, please consult our Service Team.

The following equations adjusted to the different methods apply to water:

Pulse-echo method, lateral attachment: $L_{\text{Distance}} = 2 * D_B$

$$T_{\text{Beginning}} [\text{ms}] \approx 1,2 * D_B [\text{m}] \quad T_{\text{Width}} [\text{ms}] \approx 0,4 * D_B [\text{m}]$$

Pulse-echo method, visual attachment: $L_{\text{Distance}} = 2 * F_l$

$T_{\text{Beginning}}$: visually with test output

$$T_{\text{Width}} [\text{ms}] \approx \frac{2000 * F_{\text{max}} [\text{m}]}{v_l [\text{m/s}]}$$

Ultrasonic transmission: $L_{\text{Distance}} = D_B$

$$T_{\text{Beginning}} [\text{ms}] \approx 0,6 * D_B [\text{m}] \quad T_{\text{Width}} [\text{ms}] \approx 0,2 * D_B [\text{m}]$$

Dying down method:

$T_{\text{Beginning}}$: visually with test output

T_{Width} : visually with test output

Legend:

T_{Begin} : Gate beginning
 T_{Width} : Gate width
 F_l : Filling level
 F_{max} : Max. filling level
 L_{Dist} : Distance travelled by ultrasonic signal
 D_B : Vessel diameter
 v_l : Speed of sound in liquid

Equation 2: Setting the gate

Liquid	Speed of sound
Water	1,483 m/s
Ethyl alcohol	1,180 m/s
Acetone	1,200 m/s
Diesel oil (light)	1,250 m/s
Transformer oil	1,425 m/s

Table 6: Speed of sound in selected liquids (20°C)

Note

The gate settings should always be made with the visual assistance of the test output (see chapter 4.3.2). The vessel must be filled with liquid to make the settings. A verification of the settings should be made when the vessel is empty.

The adjustment with the dying down method is made as a direct comparison of the duration of dying down with the full and the empty vessel. The rate of gain should not be set too high (approximately step 20).

6.5 Parameter P 07 / P 08: Integration Up / Down

Settings

OFF: Integration disabled (i. e. instant response)

0.100 ... 0500: Integration time Up / Down in [s]

You can use this parameter to eliminate occasional noise and to smoothen the result.

The parameter P 07 „Integration Up“ indicates how quickly the switched output is to respond when echo signals are detected in the gate.

The parameter P 08 „Integration Down“ determines the speed of response of the switched output to the lack of echo signals.

6.6 Parameter P 09: Hold time

Settings

0.100 ... 2000: Hold time in [s]

This parameter specifies the rate with which the switched output may change its state. After each change of state the hold time set here must elapse before the next change can take place.

This function prevents relay „chatter“, i.e., intolerably rapid toggling of make and break, when the liquid reaches limit level.

6.7 Parameter P 10: Switched output

Settings

0: Relay picks up when an ultrasonic signal is detected in the gate

1: Relay picks up when **no** ultrasonic signal is detected in the gate

If the controller is used as a closed-circuit device to prevent overflowing, parameter P 10 must be set as follows for the methods described in chapter 3.3:

Measuring method	Parameter P 10
Pulse-echo method with lateral attachment	1
Pulse-echo method with vertical attachment	0
Ultrasonic transmission method	1
Dying down method	0

Table 7: Settings of parameter P 10 for closed-circuit current method

For other applications (e.g. protection against dry running) set this parameter as required.

6.8 Parameter P 11: Configuration of switched output

Settings

OFF: Switched output permanently disabled

On: Switched output permanently enabled

Auto: Switched output is set to the appropriate channel as required by the level measured.



Relay 2 is not set in ultrasonic transmission mode.

6.9 Parameter P 12: Configuration of alarm switched output

SONOCONTROL 20, spec.: 1xx, single-channel

Settings
(Specification 1xx)

- OFF:** ALARM relay permanently disabled, red LED lighting
- On:** ALARM relay permanently enabled, red LED not lighting
- A C1:** ALARM relay drops (fault message) if a device fault is detected in channel 1

SONOCONTROL 20, Spec.: 2xx, 2-channel

Settings
(Specification 2xx)

- OFF:** ALARM relay permanently disabled, red LED lighting
- On:** ALARM relay permanently enabled, red LED not lighting
- A C1:** ALARM relay drops (fault message) if a device fault is detected in channel 1
- A C2:** ALARM relay drops (fault message) if a device fault is detected in channel 2
- C1u2:** ALARM relay drops (fault message) if a device fault is detected in channel 1 or channel 2

The ALARM switched output provides outputs of fault messages and works on the closed-circuit current principle. The switching contact also generates a fault message, for example, when the feeding voltage fails.

No fault
message

- Relay picked up
- Red LED in the front plate not lighting

Fault message

- Relay dropped
- Red LED in the front plate lighting (operating voltage is available)

Parameter P 12 specifies the channel to which the fault message is to relate.

6.10 Parameter P 90: Device address

Settings

0001 ... **0032:** Device address for serial port

Up to 32 devices can be connected in parallel to the RS-485 bus. It is a condition, however, that every device has a different device address.

7 Advanced Programming mode

The parameters and functions described in chapter 6 are sufficient for a convenient start-up of the SONOCONTROL 20. In addition to these, there are more functions for specific applications which increase the safety of the measuring system or make service work easier.

To start the Advanced Programming mode, a special code number must be entered.

All parameters and functions in chapter 6 are also available in the Advanced Programming mode. Therefore only the modifications will be described in the paragraphs below.

Param. No.	Spec. 1xx	Spec. 2xx	Designation	Settings
CODE	x	x	Advanced Programming mode access	1799
P 13	x	x	Calibration value for control current	100 ... 255
P 14	x	x	Display output	0: text "run" / 1: integration value
P 15		x	2nd channel configuration	0: indep. / 1: ultrason. transmiss.
P 70	x	x	Enable / interval for sensor contact verification	OFF, 5 ... 1000 s
P 71	x	x	Transmission energy for sensor contact verification	Step 1 ... 9
P 72	x	x	Gain for sensor contact verification	Step 1 ... 67
P 73	x	x	Gate beginning for sensor contact verification	0.001 ... 30 ms
P 74	x	x	Gate width for sensor contact verification	0.001 ... 30 ms
P 91	x	x	Asynchronous base interval	0.0 - 1.5 ms

Table 8: Extra parameters in Advanced Programming mode

7.1 Parameter P 13: Adjusting the control current for sensor

Settings

0100 ... **0255**: Compensation value for control current

To work smoothly, the sensors of the SONOCONTROL 20 require control current. This control current is generally compensated when the device is delivered by the manufacturer. This parameter permits you to recalibrate the current output. Please proceed as follows:

1. Disconnect the sensor (all 6 connections)
2. Connect a current meter: Channel 1 → terminals 35/36,
or Channel 2 → terminals 29/30
3. Select the measuring channel with P 02
4. Set parameter P 04 to **0067**.
5. The current should be 20.00 mA ± 0.1 mA.
6. Change parameter P 13 until 20.00 mA ± 0.1 mA is output.
7. Reset the gain with parameter P 04.
8. Save the parameters (P 99=1).
9. Disconnect the current meter and connect the sensor.

7.2 Parameter P 14: Display panel output

Settings

0: Displays standard text **run** in measuring mode

1: Displays the internal integration value in measuring mode



The switching procedure is initiated when the integration value exceeds or drops below the threshold value of 5000.

7.3 Parameter P 15: 2nd channel configuration

Settings

0: The second measuring channel works independently.

1: Ultrasonic transmission method

In ultrasonic transmission, both measuring channels co-operate:

- Sensor 1: receiver
- Sensor 2: transmitter

The setting and the evaluation (switched output REL 1) are only made in channel 1; channel 2 (with switched output REL 2) has no other function in ultrasonic transmission.

7.4 Parameter P 70: Enable / interval for sensor contact verification

Settings

OFF: Sensor contact verification disabled

0005 ... 1000: Time interval for sensor contact verification in [s]

The SONOCONTROL 20 can verify the attachment of the sensors to the vessel in regular intervals.

Parameter P 70 disables the sensor contact verification (OFF) or sets steps of a time interval between two tests in the range from 5 s to 1000 s (approx. 16 min).

Operating principle of attachment verification

Functional principle of the contact verification

To verify that the sensor is in contact with the vessel, the signal reflected by the wall after the transmission of the pulse is evaluated. For this purpose, a second gate is generated in the dying down area of the pulse. The test gate has its own transmission energy, gain and gate times.

Parameters P 71 to P 74 define the test gate. If one of these parameters is selected in programming mode, the SONOCONTROL 20 internally changes from the measuring gate to the test gate. The setting of the test gate should preferably be made with an oscilloscope connected to the test output. The arrow on the display panel (cf. chapter 6.3) and the switched output also indicate the test gate during parameter setting.

Please try which setting of parameters provides the best verification of the sensor contact with the vessel with or without liquid on sensor level.

Attachment verification
with ultrasonic
transmission method

Contact verification with ultrasonic transmission method

In ultrasonic transmission, both channels operate separately while the sensor contact is being verified. Therefore, separate settings of parameters P 71 to P 74 must be made for both sensors. To set the sensor contact verification parameters, it is therefore necessary to disable the ultrasonic transmission (P 15=0). When the settings of parameters P 71 to P 74 have been made for both sensors, switch the SONOCONTROL 20 back to ultrasonic transmission (P 15=1).



In ultrasonic transmission and when the sensor contact verification is disabled, several fault messages cannot be generated (e.g., fault message indicating wrong wiring). The sensor contact verification function should therefore not be disabled, if possible.

Interruption of the measurement process during contact verification

! Interruption of
measurement during
attachment verification

Measurement is interrupted for the duration of the sensor contact verification test. The test duration is 250 ms to 2 s. To run applications which do not tolerate even a brief interruption of the measuring process, the contact verification function should therefore be disabled. In this case, the sensor contact should be verified during the regular inspection. The parameters of the sensor contact verification can be set and therefore adjusted to the shortest possible duration. Please observe the information in the following paragraphs.

7.5 Parameter P 71: Transmission energy for sensor contact verification

Settings

0001 ... **0009**: Steps of the transmission energy for sensor contact verification

If possible, parameter P 71 should be set to the same value as parameter P 03, this reduces the time required to verify the sensor attachment. Also see chapter 6.2.

7.6 Parameter P 72: Gain for sensor contact verification

Settings

0001 ... **0067**: Gain step for sensor contact verification

Before setting this parameter, read the information regarding parameter P 04 in chapter 6.3.

7.7 Parameter P 73 / P 74: Gate beginning / gate width for sensor contact verification

Settings

0.001 ... **30.00**: Gate beginning in [ms]

0.001 ... **30.00**: Gate width in [ms]

Before setting this parameter, read the information regarding parameters P 05/ P 06 in chapter 6.4.

When defining the start of the test gate, make certain that no signal is reflected when the sensor is not attached. The door should only be wide enough to ensure that no reflected „useful“ signal is received.

7.8 Parameter P 91: Asynchronous cycle rate

Settings

0.000 ... **1.500**: Offset from the base interval in [ms] in steps of 0.100 ms

If several SONOCONTROL 20s are connected to one vessel it may happen that the units interfere with each other. In this case each unit should use a different cycle rate. Therefore specify a different value for parameter P 91 for each SONOCONTROL 20.

Although this will not eliminate the reciprocal ultrasonic interference, the comprehensive integration function (see chapter 6.5) however provides efficient protection from wrong measured results.

The two measuring channels of a 2-channel SONOCONTROL 20 cannot interfere with each other.

8 Serial port

The SONOCONTROL 20 has a serial port for setting parameters and poll measured data.

If the serial port is enabled, the SONOCONTROL 20 switches to programming mode. Parameter setting via the keypad and the serial port are therefore exclusive of each other. If, for example, parameters are set via the serial port, the SONOCONTROL 20 will not respond to the press of a button and the information **r485** is shown on the display panel to indicate the current status. Only when communication ends, the previous information will again appear on the display panel.

Conversely, i. e., if parameters are being set via the keypad, the SONOCONTROL 20 will only respond to attempts to establish a link via the serial port after the keypad entries have been completed.

8.1 Hardware specification

The SONOCONTROL 20 is equipped with a RS-485 interface. Up to 32 devices can be connected in parallel to the data lines form a bus. Each device is assigned an address, a number from 01 to 32.

Data is transferred in semi-duplex mode, i. e., data is sent and received by the same line. Only one subscriber can transmit data, while the other devices are receiving. The figure below illustrates the working principle for a RS-485 bus with SONOCONTROL 20 devices: Like terminals of all units must be connected with each other.

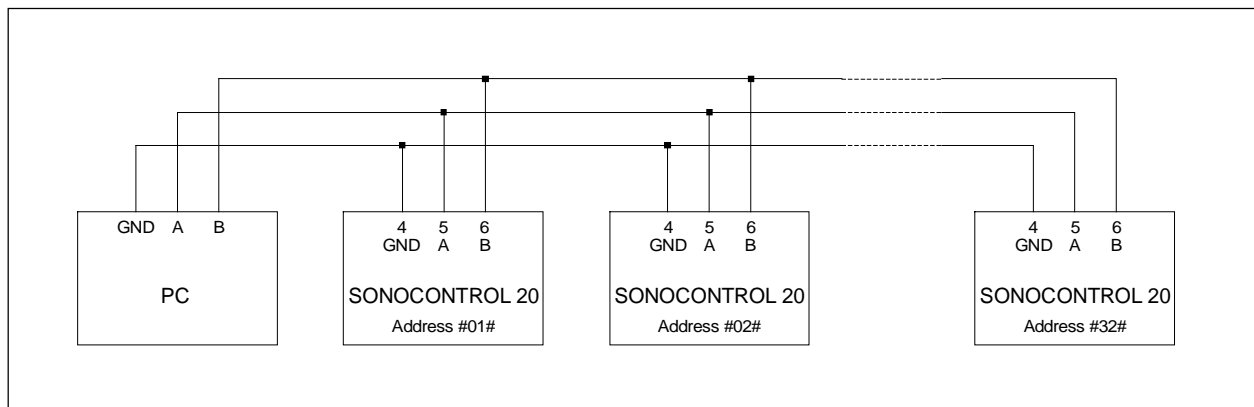

Figure 17: RS-485 wiring principle

Communication via the serial port follows the master-slave principle. The master, usually your PC, a terminal device, or a similar device, always works as the transmitter and controls the data exchange. It functions as a receiver only to receive data.

The SONOCONTROL 20 is the slave performing the instructions it receives from the master. For this purpose, the serial port of the SONOCONTROL 20 always works as a receiver. It transmits data only if instructed and returns to receive mode after it.

*RS232 ↔ RS485-
converter*

If a PC is to function as the master, an RS-485 interface must usually be installed. The required RS-485 plug-in module (mostly with electrical isolation) are available commercially.

As an alternative, an adapter can be used that fits the RS-485 standard to the standard RS-232 port of your PC. The RS-232 port of a PC usually has separate lines for reception and transmission. Both lines are brought together in the adapter. For this multiplexing mode to operate smoothly, information on the direction of the data flow, i. e., transmission or reception, is required. Most suppliers of RS232-RS485 adapters use the RS-232 control lines RTS or DTR. For details, please see the user instructions of your adapter.

Port configuration

Please configure your serial port as follows:

Baud rate 9600 Bit/s, 8 data bits, 1 stop bit, no parity.

8.2 Log

Communication with the SONOCONTROL 20 proceeds in the form of instructions which consist of ASCII characters. Each instruction is concluded by a carriage return character (symbol: <CR>, value: 13_{dec} = 0D_{hex}). The SONOCONTROL 20 accepts only capital letters, digits and several special characters. The instruction format is the following:

#ADDRESS# INSTRUCTION WORD=VALUE<CR>

- ADDRESS is the device address (see chapter 6.10) of the respective device, it is preceded and followed by the "#" lozenge sign.
If you want to address all devices at the same time, you can specify "ALL" between the two lozenge signs. This works only with so-called set instructions (see below).
- INSTRUCTION WORD indicates the key word for the respective parameter, see chapter 8.3, Set of instructions for serial port.
- The equal sign separates the instruction word from the instruction value. It must always be entered.
- VALUE stands for a number of question mark "?". This is the difference between instructions which *set* a parameter to a certain numerical value and instructions which *inquire* for the number value of a parameter.

If an inquiry instruction is sent, the respective SONOCONTROL 20 replies to the inquiry. The reply uses the same format as the instruction, i.e., it consist of the address, the instruction word and the numerical value.



1. There are two instruction for which the use of the equal sign and the VALUE and is forbidden. These instructions are "EXIT" to quit the communication with the SONOCONTROL 20 and "SAVE" to permanently save the date input .
2. On the other hand, there are instruction words that are only allowed in inquiry instructions or only in setting instructions. The former group, for example, comprises measured values or device type, the latter the access code and the reset instructions.
3. Serial parameter setting supports only integers. Therefore smaller units than those shown on the display panels must be used.
4. Instructions that are unknown or do not conform to the format are ignored. As the SONOCONTROL 20 can only transmit as a slave on the instruction of the master, it **cannot output any fault messages** on its own.

*Establishing a link,
entering the code
number*

Parameter setting by the serial port is very similar to the parameter input via the keypad. All parameters relate to the current channel.

At first, the link with the SONOCONTROL 20 is established by means of a CODE instruction. The code is of the same value as the code number entered via the keypad. Again, the parameters are set on two levels. If the code is valid, the keypad of the SONOCONTROL 20 will be blocked until you quit the serial communication by entering EXIT or the system does not detect any instructions for approximately 16 minutes. You can also go from one programming level to the other with the CODE instruction.

8.3 Set of instructions for serial port

Parameter P 01: Access code

a) To establish a link

Instruction word: CODE

Instruction class: Set

Value range: 0345 for normal parameter setting
1799 for Advanced Programming mode

b) To go to another parameter setting level

Instruction word: CODE

Instruction class: Set

Value range: 0345 for normal parameter setting
1799 for Advanced Programming mode

c) Quit serial communication

Instruction word: EXIT

Instruction class: non-parameterised instruction

Parameter P 02: Channel

Instruction word: CH

Instruction class: Set and inquire

Value range: 1..2

Parameter P 03: Transmission energy

Instruction word: ENERGY

Instruction class: Set and inquire

Value range: 1..9 [in steps]

Parameter P 04: Gain

Instruction word: GAIN

Instruction class: Set and inquire

Value range: 1..67 [in steps]

Parameter P 05: Gate beginning

Instruction word: GATEBEG

Instruction class: Set and inquire

Value range: 1..30000 [μ s]**Parameter P 06: Gate width**

Instruction word: GATEWID

Instruction class: Set and inquire

Value range: 1..30000 [μ s]**Parameter P 07: Integration time Up**

Instruction word: AVRUP

Instruction class: Set and inquire

Value range: 0..12 [in steps], with the following meaning:

Step	Integration time	Step	Integration time	Step	Integration time
0	no integration	5	2 s	10	100 s
1	0.1 s	6	5 s	11	200 s
2	0.2 s	7	10 s	12	500 s
3	0.5 s	8	20 s		
4	1 s	9	50 s		

Parameter P 08: Integration time Down

Instruction word: AVRDN

Instruction class: Set and inquire

Value range: 0.. 12 [in steps], with the following meaning:

Step	Integration time	Step	Integration time	Step	Integration time
0	no integration	5	2 s	10	100 s
1	0.1 s	6	5 s	11	200 s
2	0.2 s	7	10 s	12	500 s
3	0.5 s	8	20 s		
4	1 s	9	50 s		

Parameter P 09: Hold time

Instruction word: OUTPER

Instruction class: Set and inquire

Value range: 0..13 [in steps], with the following meaning:

Step	Hold time	Step	Hold time	Step	Hold time
0	01 s	5	5 s	10	200 s
1	0.2 s	6	10 s	11	500 s
2	0.5 s	7	20 s	12	1000 s
3	1 s	8	50 s	13	2000 s
4	2 s	9	100 s		

Parameter P 10: Switched output

Instruction word: SWTYPE

Instruction class: Set and inquire

Value range: 0..1, with the following meaning:

No.	Switched output
0	Relay picks up if echo is detected
1	Relay picks up if no echo is detected

Parameter P 11: Relay configuration

Instruction word: REL

Instruction class: Set and inquire

Value range: 0..2, with the following meaning:

No. Configuration	No. Configuration
0 permanently disabled	2 switches as required
1 permanently enabled	by liquid level

Parameter P 12: Alarm switched output configuration

Instruction word: ALARMREL

Instruction class: Set and inquire

Value range: 0..2 for specification 1xx, 0..4 for specification 2xx, with the following meaning:

No. Configuration	No. Configuration
0 permanently disabled	3 Switches only if fault in channel 2
1 permanently enabled	4 Switches if fault in channel 1 or
2 Switches only if fault in channel 1	channel 2

Parameter P 13: Compensation of control current for sensor

Instruction word: CALGAIN

Parameter setting level: Advanced Programming mode only

Instruction class: Set and inquire

Value range: 100..255

Parameter P 14: Output mode

Instruction word: DISPLTXT

Parameter setting level: Advanced Programming mode only

Instruction class: Set and inquire

Value range: 0..1, with the following meaning:

No. Output mode
0 Standard text „run“
1 Displays the integration counter of the selected channel

Parameter P 15: Configuration of second measuring channel

Instruction word: ASSIGNCH2

Parameter setting level: Advanced Programming mode only

Instruction class: Set and inquire

Value range: 0..1, with the following meaning

No. Configuration
0 Second channel works independently of the first channel
1 Enables an ultrasonic transmission configuration in which the second channel transmits the pulse and the first channel receives the echo



This instruction is only available if your SONOCONTROL 20 is a 2-channel type (specification 2xx). If the SONOCONTROL 20 operates in ultrasonic transmission mode, only one measuring channel is available. Parameter P 02 (channel) is blocked, access to the parameters of the second channel is not possible.

Parameter P 70: Enable / interval for sensor contact verification

Instruction word: SELFTEST

Parameter setting level: Advanced Programming mode only

Instruction class: Set and inquire

Value range: 0..6 [in steps], with the following meaning:

Step	Time interval	Step	Time interval
0	disabled	4	100 s
1	5 s	5	500 s
2	10 s	6	1000 s
3	50 s		

Parameter P 71: Transmission energy for sensor contact verification

Instruction word: TESTENERGY

Parameter setting level: Advanced Programming mode only

Instruction class: Set and inquire

Value range: 1..9 [in steps]

Parameter P 72: Gain sensor contact verification

Instruction word: TESTGAIN

Parameter setting level: Advanced Programming mode only

Instruction class: Set and inquire

Value range: 1..67 [in steps]

Parameter P 73: Gate beginning sensor contact verification

Instruction word: TESTBEG

Parameter setting level: Advanced Programming mode only

Instruction class: Set and inquire

Value range: 1..30000 [μ s]**Parameter P 74: Gate width sensor contact verification**

Instruction word: TESTWID

Parameter setting level: Advanced Programming mode only

Instruction class: Set and inquire

Value range: 1..30000 [μ s]**Parameter P 90: Device address**

This parameter can only be set via the keyboard, it is a precondition for communication via the serial interface.

Parameter P 91: Asynchronous cycle rate

Instruction word: ASYNCH

Parameter setting level: Advanced Programming mode only

Instruction class: Set and inquire

Value range: 0..15 [in steps], with the following meaning:

Step	Offset from base interval	Step	Offset from base interval
0	0, disabled	8	800 μ s
1	100 μ s	9	900 μ s
2	200 μ s	10	1.0 ms
3	300 μ s	11	1.1 ms
4	400 μ s	12	1.2 ms
5	500 μ s	13	1.3 ms
6	600 μ s	14	1.4 ms
7	700 μ s	15	1.5 ms

Parameter P 92: Software version

Instruction word: VERSION

Instruction class: Inquire

Feedback value: xxyy (as decimal number without decimal point); with the following meaning:

xx: principal version, yy: sub-version

Function P 98: Copy parameter sets

Instruction word: COPYALL

Instruction class: Set

Value range: 0.1; this function is only implemented in specification 2xx devices. To prevent accidental copying, enter "1" as confirmation, "0" or no entry cause no activity.

Function P 99: Save parameters

Instruction word: SAVE

Instruction class: non-parametrised instruction

No value range defined

Parameter P 101: Device configuration

Instruction word: IDENT

Instruction class: Inquiry

The device type can be inquired with this instruction.

Value range: 0: SONOCONTROL 20 specification 1xx
1: SONOCONTROL 20 specification 2xx

Parameter P 102: Release or block measuring procedure

Instruction word: ENABLE

Parameter setting level: Advanced Programming mode only

Instruction class: Set and inquire

Value range: 0.1; with the following meaning:

- 0: Blocks the measuring procedure, the sensors carry out no more measuring function. No fault message is generated. This instruction is particularly of interest for applications with several SONOCONTROL 20 units on one vessel (redundant configuration). Normally, the units would interfere with each other (acoustic cross-talk).
- 1: Release measuring procedure, normal operating state. An explicit release of the measuring procedure is only required after a previous blockage.

Parameter P 103: Reset

Instruction word: RESET

Parameter setting level: Advanced Programming mode only

Instruction class: Set

Value range: 0.1; to avoid accidental reset, confirm by entering "1", "0" or no entry cause no activity.

The SONOCONTROL 20 makes the reset of the internal microcomputer. The parameter entries in the EEPROM are not erased, parameters not saved will be lost.

Parameter P 104: Total reset

Instruction word: TOTALRESET

Parameter setting level: Advanced Programming mode only

Instruction class: Set

Value range: 0.1; to avoid accidental reset, confirm by entering "1", "0" or no entry cause no activity.

The SONOCONTROL 20 makes the total reset of the internal microcomputer. The parameter entries in the EEPROM are erased and replaced by the default settings.

Parameter P 105: Inquire status

Instruction word: STATE

Instruction class: Inquire

Feedback value: 0..127

For the correct interpretation of the returned number a binary evaluation of all bits must be made. They have the following meanings:

- Bit 0: Echo flag CH1: An echo of the pulse just transmitted has been detected in channel 1.
- Bit 1: Echo flag CH2: An echo of the pulse just transmitted has been detected in channel 2.
- Bit 2: Integration flag CH1: Indicates that the integration sum in channel 1 exceeds 5000 (threshold number to trigger the switching signal).
- Bit 3: Integration flag CH2: Indicates that the integration sum in channel 2 exceeds 5000 (threshold number to trigger the switching signal) .
- Bit 4: Alarm relay switching state: Indicates if the alarm relay has or has not picked up.
- Bit 5: Relay 1 switching state: Indicates if relay 1 has picked up.
- Bit 6: Relay 2 switching state: Indicates if relay 2 has picked up.
- Bit 7: always 0

Parameter P 106: Inquire fault

Instruction word: ERROR

Instruction class: Inquire

Feedback value: 0..255, see chapter 9.2.

The number xx of the fault is output and shown as **F xx** on the display panel. If several faults are detected at the same time, the number of the most serious fault is displayed. If this is repaired, the fault that is next less serious, is shown, and so on, until all faults have been shown.

If the SONOCONTROL 20 works properly, the feedback is zero.

Parameter P 107: Inquire warnings

Instruction word: WARNING

Instruction class: Inquire

Feedback value: 0..255, see chapter 9.3.

This parameter has the same function as parameter P 106.

9 Troubleshooting

9.1 Troubleshooting

If your SONOCONTROL 20 does not respond to the presence of liquid as it should, the fault must be located. As a first step, find out if the problem is sonic or electrical. Please work through the following checklist.

- Is the SONOCONTROL 20 supplied with operating voltage?
- Is the sensor connected properly?
- Is the sensor making full contact with the mounting compound?
- Is there liquid in the vessel/tube?
- Are the settings of gate beginning and gate width correct?
- Does noise by sound reflection on the vessel wall interfere with the measuring process in the gate?
- Does the liquid contain a large number of baffles or bubbles?
- Is there strong turbulence?
- Is the setting of the transmission energy and/or the gain low?
- Does product stick to the vessel walls?
- Has the liquid changed in the course of operation?
- Has the temperature or the concentration of the liquid changed substantially?
- Is equipotential bonding ensured between the vessel and the housing?
- Are both shields of the sensor cable properly connected to earth?
- For ultrasonic transmission: Are the sensors in correct alignment with each other?
- For dying down: Do reflections from the opposite wall interfere with the gate?
- For pulse-echo method: Is there an object which reflects the ultrasonic signals (e. g. the opposite wall of the vessel or tube)?

If the SONOCONTROL 20 detects a device fault, an appropriate message is displayed on the display panel. The evaluation is different for faults and warnings. For details, see the respective passages of this Manual.



Call our service team if you have a problem. We will be glad to assist you to ensure smooth service of your SONOCONTROL 20.

9.2 Device faults

Device faults either affect or prevent measurement. If a fault is detected, the alarm relay drops, the appropriate LED lights and a fault message is shown on the display panel. If several faults are detected at the same time, the most serious fault is shown. The fault code on the display panel can be polled via the serial port if the SONOCONTROL 20 was not stopped.

In the 2-channel SONOCONTROL 20 the fault code of the current channel is displayed or output via the serial port.

F The hash total by the program memory is wrong. This is a particularly grave fault. The SONOCONTROL 20 would cease to operate properly and was therefore stopped. If this fault occurs, please call our service team.

F The hash total by the non-volatile parameter memory is wrong. You can make a total reset by pressing the selection key and a new start of the device. Please contact our service team for repair of defective assemblies.

F The device software is not compatible with the device hardware. Please inform our service team.

F The device software contains a wrong software version. Please inform our service team.

F The main memory in the device is defective. As the saved parameter settings are no longer secure, the measuring process is discontinued and device stopped. Please contact our service team.

F The internal working memory of the microcomputer is defective. The device was stopped. Please inform our service team.

F A difference between the (working) parameter set and the contents of the non-volatile parameter memory has been found. Please verify your parameter settings and save them again. If the same fault occurs again, the computer hardware is defective. Please consult our service team.

F The sensor enable circuitry works not right. Please check the connections to the probe. A possible cause may be that the fuse for the actual channel is defective (125mA/T). Please call our service team to repair the defect.

F The acoustic attachment of the sensor to the vessel is interrupted or impaired. Inspect the sensor contact or the settings of parameters P 71 to P 74.



Detection of fault F 10 must be permitted by parameter P 70.

F The sensor detects a signal although no signal should actually be present at this time. The cause is a defect in the sensor and/or in the SONOCONTROL 20. Please contact our service team.



Detection of fault F 11 must be permitted by parameter P 70.

F The sensor detects no signal. Possible causes include a broken cable, a defect in the electronic circuitry of the sensor. If a wiring check is inconclusive, please inform our service team.

9.3 Warnings

Warnings inform the user that the measuring process is not proceeding along the optimum line. Warnings are caused by parameters that are not the best. The measuring result will not be affected.

The warning code can be polled serially.

Currently only one warning is generated by the SONOCONTROL 20:



The parameters have not been saved permanently. You quit the programming mode with P 99 = 0 or the SONOCONTROL 20 automatically returned to the measuring mode after not detecting any button activity or receiving a serial instruction for 16 minutes.

The warning F 09 is indicated periodically by „flashing“ for a brief moment.

10 Default settings

The devices are delivered with the following default settings:

Param. No.	Designation	Reset values
P 02	Channel selection	CH1
P 03	Transmission energy	Step 1
P 04	Gain	Step 10
P 05	Gate beginning	0.2 ms
P 06	Gate width	0.1 ms
P 07	Integration Up	1 s
P 08	Integration Down	1 s
P 09	Hold time	0.5 s
P 10	Switched output	0, i.e. relay on if echo in gate
P 11	Relay	auto, switched by level
P 12	Alarm relay	auto on all available channels
P 13	Calibration of control current	200
P 14	Unit of measurement for display panel	0, i.e. standard text "run"
P 15	2nd channel configuration	0, i.e. independent of 2nd channel
P 70	Enable / interval for sensor contact verification	0, i.e. blocked
P 71	Transmission energy for sensor contact verification	Step 1
P 72	Gain for sensor contact verification	Step 10
P 73	Gate beginning for sensor contact verification	0.001 ms
P 74	Gate width for sensor contact verification	0.015 ms
P 90	RS485 device address	1
P 91	Asynchronous base interval	0.0 ms
P 92	Software version	xx.yy
P 98	Copy parameters	0
P 99	Save parameters	0

Table 9: Default settings



The above default settings will also be adopted after a total reset. A total reset can be made by pressing all three buttons when the device is switched off, then the device is switched on and the buttons are held pressed until the display panel goes blank.

11 Technical data

SONOCONTROL 20: Universal Level Limit Switch for Liquids

Device types	SONOCONTROL 20 <ul style="list-style-type: none"> • Specification 1xx: one measuring channel • Specification 2xx: two measuring channels
Sensors measuring frequency, form of construction	Sensor AE 01: 1 MHz <ul style="list-style-type: none"> • Spec. 01: Screw-on module • Spec. 05: Screw-type thread M30x1.5 Sensor AE 20: 0.5 MHz <ul style="list-style-type: none"> • Spec. 01: Screw-on module • Spec. 05: Screw-type thread M45x1.5
Measuring principle	Echo time measurement <ul style="list-style-type: none"> • Pulse-echo method with lateral attachment • Pulse-echo method with vertical attachment • Ultrasonic transmission • Dying down
Attachment of sensors	Without exposure to measured liquid, attached to outside of vessel, or directly in the liquid
Length of sensor cable	max. 300 metres, max. resistance: 10 Ω each wire
Parameter setting	<ul style="list-style-type: none"> • Digital setting by buttons via display panel or • Via serial interface • Unauthorised access control by code number
Measuring range	Maximum transmission time: 32 ms (approx. 23 m with water)
Resolution	Gate beginning/ gate width: 1 μ s
Frequency of measuring sequence	Approx. 10 Hz
Display	Digital display for parameter setting and service
Switched outputs	1 switched output for each measuring channel and 1 switched output for fault output, each <ul style="list-style-type: none"> • Designed as changeover contact • Maximum switching voltage: <ul style="list-style-type: none"> Specifications xx1 and xx2: 50 V Specification xx3 and higher: 250 V • Maximum switching current: 5 A
Interface	Serial Interface RS-485 for measured-value polling and parameter setting, Semi-duplex mode, max. 32 devices on bus
Voltage supply	SONOCONTROL 20: 19 ... 30 V AC/DC, 500 mA, protected against polarity reversal, approx. 1 s response time after start of operating voltage AE series sensor: +15 VDC/ 100 mA, supplied by the SONOCONTROL 20

Housing	SONOCONTROL 20: plastic, L x W x H: 100 x 75 x 110 mm, IP20 AE series sensor: Aluminium, L x W x H: 103 x 75 x 92 mm, IP65
Connections	Plug-type screw terminals
Mounting	SONOCONTROL 20: Standard mounting rail 35mm AE series sensor: Mounting ring/mounting plate on vessel
Temperature range	SONOCONTROL 20: -20 ... +70 °C AE series sensor: -20 ... +80°C
Insulation resistance	Double basic insulation according to EN 61010-1 between all circuits
CE conformity	EC directives and other legislation 89/336/EEC and 92/31/EEC (Electromagnetic Compatibility), 73/23/EEC and 93/68/EU (Low Voltage Directive) <ul style="list-style-type: none"> • EMC, noise radiation emission: DIN EN 50081, Part 1 (VDE 0839, Part 81-2) DIN EN 55011 • EMC, noise immunity: DIN EN 50082, Part 2 (VDE 0839, Part 82-2): EN 61000-4-2, EN 61000-4-3, EN 61000-4-4, EN 61000-4-6 • Low Voltage Directive: EN 61010-1, EN 61010-1/A2
Scope of supply	SONOCONTROL 20, AE series ultrasonic sensor, user's manual
Accessories	Sensor fasteners, sensor cable, mounting compound

Table 10:
Technical data

Param.- No.	Designation	Settings	Your Settings CH1	Your Settings CH2
P 02	Channel selection	CH1 / CH2		
P 03	Transmission energy	Step 1 ... 9		
P 04	Gain	Step 1 ... 67		
P 05	Gate beginning	0.001 ... 30 ms		
P 06	Gate width	0.001 ... 30 ms		
P 07	Integration up	OFF, 0.1 ... 500 s		
P 08	Integration down	OFF, 0.1 ... 500 s		
P 09	Hold time	0.1 ... 2000 s		
P 10	Switched output	0: relay closed on echo, 1: inverted		
P 11	Relay	OFF / On / auto		
P 12	Alarm relay	OFF / On / auto (auto CH1 / CH2 / CH1+CH2)		
P 13	Calibration value for control current	100 ... 255		
P 14	Display output	0: text "run" / 1: integration value		
P 15	2nd channel configuration	0: indep. / 1: ultrason. transmiss.		
P 70	Enable / interval for sensor contact verification	OFF, 5 ... 1000 s		
P 71	Transmission energy for sensor contact verification	Step 1 ... 9		
P 72	Gain for sensor contact verification	Step 1 ... 67		
P 73	Gate beginning for sensor contact verification	0.001 ... 30 ms		
P 74	Gate width for sensor contact verification	0.001 ... 30 ms		
P 90	RS485 device address	1 ... 32		
P 91	Asynchronous base interval	0.0 - 1.5 ms		
P 92	Software version	yyxx: read only		
P 98	Copy parameters	0: no copy / 1: copy		
P 99	Save parameters	0: no save / 1: save		

Place of Measurement:
Others:

Date: