



Installation and operating instructions

Level – Radar

REFLEX RADAR VG SERIES



**Hycontrol Limited, Larchwood House, Orchard Street,
Redditch, Worcestershire, B98 7DP.**

**Tel: + 44 (0)1527 406800 Fax: +44 (0)1527 406810
Email: sales@hycontrol.com Web: www.hycontrol.com**

Software History

Introduction		Signal converter		User program		Instructions	
Mth./Yr	Hard-ware	Firmware	Hard-ware	Operating system	Soft-ware	Device	User program
04/00		7.00PREnn	PC	DOS 5.0 and higher	PC-CAT 3.02 PRE01	05/00	7.02221.11+ Suppl. instruction
				Win95/98/NT	PC-CAT Win 4.00		Online help
Test versions for VG SERIES.							
07/00	VG SERIES	7.00	PC	DOS 5.0 and higher	PC-CAT 3.01	07/00	7.02221.11+ Suppl. instruction
				Win95/98/NT	PC-CAT Win 4.0		Online help
First series version for VG SERIES							

Items included with supply

The scope of supply includes, in the version as ordered:

- Signal converter bolted to waveguide window and antenna; optionally: antenna extension, sunshade (with fastening material in each case)
- Shielding material with tightening strap (not for the US market)
- Installation and operating instructions plus instruction card
- Report on factory settings for the signal converter
- Certification and approval documents, unless reproduced in the device documentation

Installation material (stud bolts, flange gasket and cabling) not supplied, to be provided by customer!

Contents

1	Handling and storage	3
2	Installation.....	4
	2.1 Field assembly	4
	2.2 Mechanical installation.....	5
3	Electrical connection	7
4	Setting the parameters.....	8
5	Maintenance, error handling	16
6	Safety information.....	16
7	Technical data (extract)	17
8	VG SERIES Level-Radar Type code	18
9	Parameter check list.....	20

Product liability and warranty:

i

The VG SERIES level gauge is designed solely for measuring the level, distance, volume and reflection of liquids, pastes, slurries, particulate materials and solids.

Local codes and regulations apply to its use in hazardous areas.

Responsibility as to suitability and intended use of these level gauges rests solely with the user.

Improper installation and operation of our level gauges may lead to loss of warranty.

In addition, the "General conditions of sale", form the basis of the purchasing contract.

If you need to return the level gauge to the manufacturer or supplier, please refer to the information given in Section 5

1 Handling and storage

Safety advice

Depending on the version, the device will weigh between approx. 5 kg and 30 kg. To carry, use both hands to lift the device carefully by the converter housing. If necessary, use lifting gear.



When handling the VG SERIES, avoid hard blows, jolts, impact, etc.

When storing the "Wave-Stick" version, make sure that the device is not placed on its side on the PTFE antenna, as this may cause the rod to bend.

2 Installation

Most of the VG SERIES versions are supplied in fully assembled condition. In this case, you may skip this chapter. However, if a device should be delivered in parts, or parts are subsequently replaced, the following should be noted.

2.1 Field assembly

- For any necessary field assembly of the VG SERIES, all parts are included with the supply (stud bolts, washers, etc.).
- Bolt the waveguide window (flange mount) or distance piece, if supplied loose, to the VG SERIES. Torque for the sets of 4 Allen screws **M** (key size 5 mm): max. 8 Nm ~ 0.8 kpm (5.8 ft lbf).
- **Note:** Ensure the upper Teflon plug is kept absolutely dry and clean! Moisture and dirt will impair functionality of the VG SERIES!
- Bolt antenna extension to the antenna; torque for the 3 stud bolts **A**: max. 8 Nm ~ 0,8 kpm (5.8 ft lbf).

Do not detach bolts **H** !

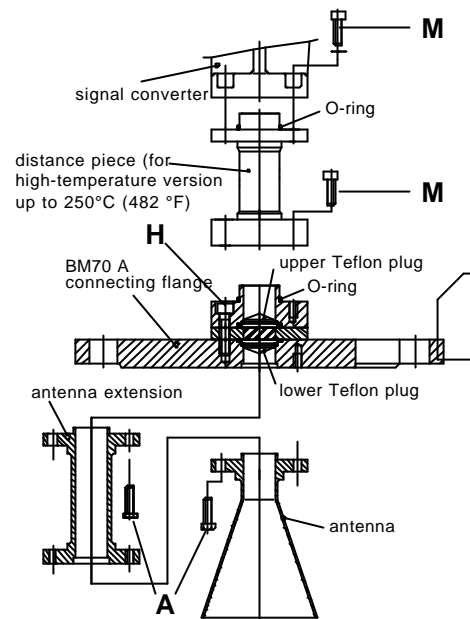

Version:

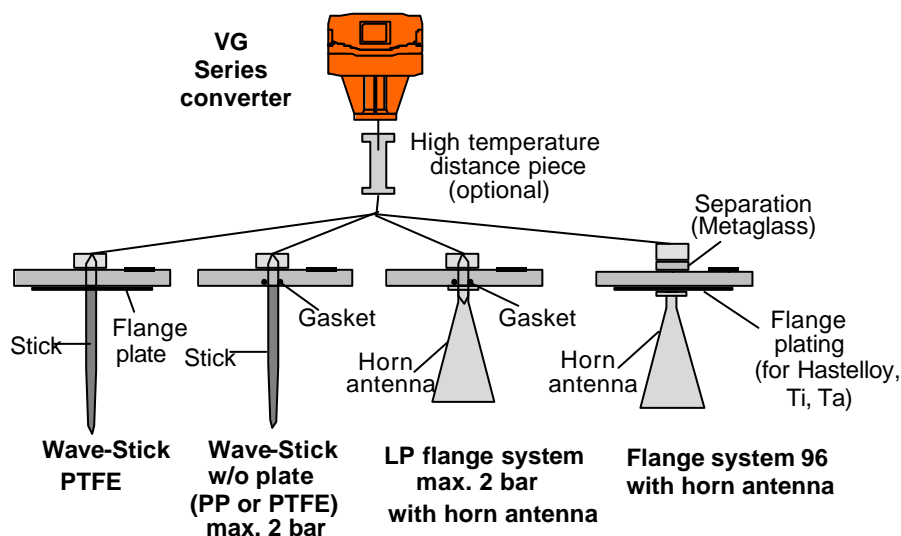

2.2 Mechanical installation

Hazardous-duty systems:

- The VG SERIES Ex is certified in conformity with **European Standard** for use in Zone 0, 1 and 2 hazardous locations (dependent on version).
- Attention is drawn to the data and information given on the **nameplate of the converter**, the **nameplate of the flange** and the specifications in the **approval certificates**.

Safety:

- Check **material compatibility** of antenna, extension, flange, gaskets, and PP or PTFE (used in all versions) with the product! See also section 8 "Type code"!



Mounting on the tank nozzle

a) Devices with horn antenna:

The antenna should project out of the nozzle. If necessary, use an antenna extension. Exception: in case of a symmetrical tank fitting.

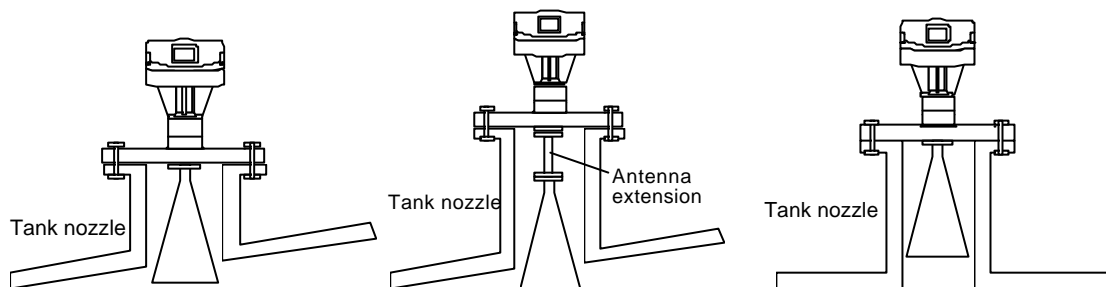

b) Wave-Stick

Note the requirements imposed on nozzle diameter and nozzle length:

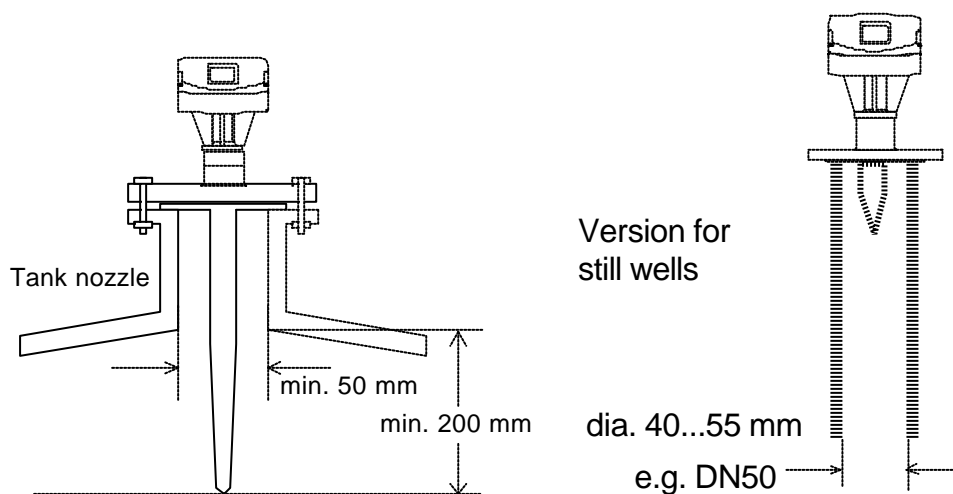

c) Purging device

Remove screw plug 1/4" R and screw in screwed tube joint, e.g. Ermeto 1/4" R.

Consult "Ex" specifications relating to the purging circuit (provided by customer)!

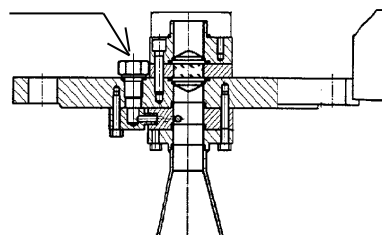

Installation on the tank

- Do not forget the gasket when positioning the VG SERIES on the tank nozzle flange. Align VG SERIES and gasket, slightly tighten nuts on stud bolts (by hand).
- Press **shielding strip C*** in the gap between tank and VG SERIES flanges and secure with **strap retainer S*** (both items included with supply).
- **Strap retainer S*** must fit closely and overlap both flanges.
* only required for European radio approvals
- Tighten down stud bolt nuts firmly. The tightening torque is dependent upon the strength properties of the stud bolts and the pressure rating of the tank

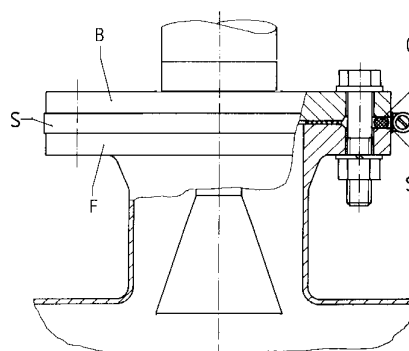

C* = shielding strip B = VG SERIES flange
S* = strap retainer F = tank flange

Positioning on the tank

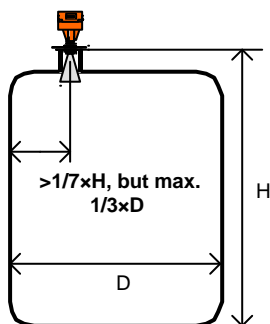

Recommended **distance**
From the tank wall

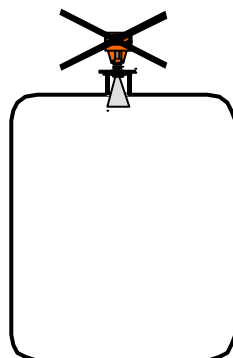

Do not position
Tank **centerline!**
(Multiple reflections!)

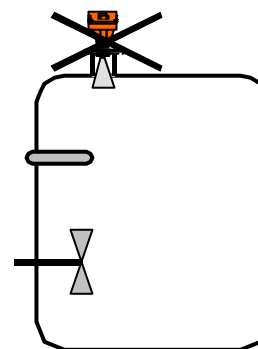

Do not position
Above **internals!**
(interference reflections!)

A **Stilling well** or **Wave-Guide** may be mounted in any position on the tank!

When using the PTFE Wave-Stick in hazardous areas of Zone 0, any electrostatic charging of the stick, e.g. by flow of product, must be avoided!



3 Electrical connection

To open the signal converter, please use a screwdriver and release the four visible screws on top of the blue housing.

Terminal assignment

VG SERIES:

The polarity of the 4-20 mA connection is arbitrary.

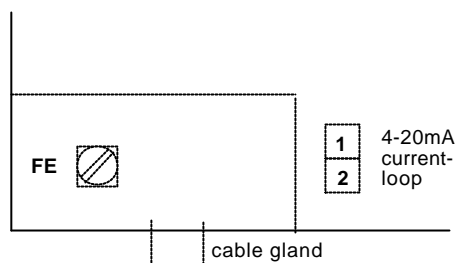

Equipotential bonding

When used in hazardous areas, the VG SERIES Ex **can** be incorporated in the **PA equipotential bonding system**, e.g. by using the separate U-clamp terminal at the “neck” of the VG SERIES Ex.

Rated temperature of connecting cables: see Section 6.

Supply voltage at the terminals (1,2)

The 4-20 mA supply must be able to provide the following voltage U at the terminals of the VG SERIES – dependent on the current I . Please consider also the line resistance and possible loads on the secondary side of the supply unit.

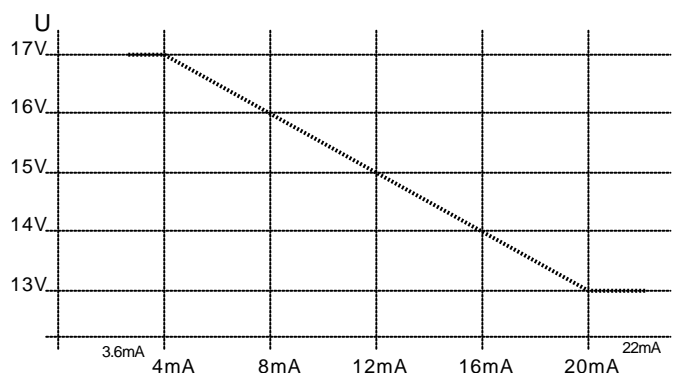

The allowed upper limit R for load+line resistance is depending on the specification of the supply unit:

$U @ 20\text{mA}$ (supply unit)	14 V	15 V	16 V	17 V	18 V
Max. resistance R	50 ?	100 ?	150 ?	200 ?	250 ?

4 Setting the parameters

Setting parameters via program PC-CAT

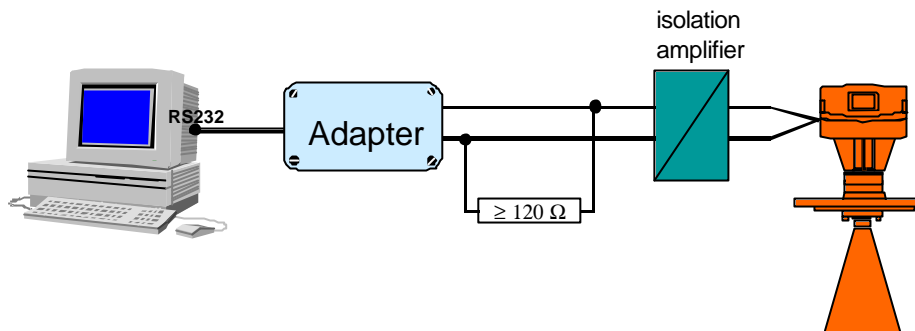

With the program PC-CAT, version 3.01 or higher, you can configure VG SERIES instruments in a very comfortable way from a PC. Connect the non-intrinsically safe side of the isolation amplifier over a load between 120Ω and 350Ω to the Smart adapter (delivered together with PC-CAT) and connect it with a serial port of the PC.

The used isolation amplifier must be HART® compatible.

Local display (optional)

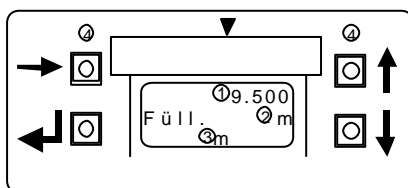

- (1) Numeric display, measured values
- (2) Alphanumeric display, function/unit
- (3) 6 Markers to display measurement status
- (4) 4 keys for configuration and error interrogation

Function of keys (only together with local display)

Operator control can be carried out with the aid of local display unit after opening the housing. However, a particularly convenient form of parameter setting is offered by the PC program PC-CAT (special accessories, see above).

- ⇒ (cursor key) - selects the configuration menu,
 - branches the menu to the next lower level,
 - shifts the cursor* to the next column on the right.
- ↑ resp. ↓ (select key) - branches the menu to the next digit on the same
 level,
 - changes the content (digit, text character) at the
 cursor* position.
- ↵ (ENTER key) - branches the menu to the next higher level,
 - stores newly entered parameters,
 - executes displayed functions,
 - selects special functions (e.g. error memory,
 see Sect. 5).

* The cursor position is signalled by flashing of the character at the appropriate place.

Meaning of status markers (only for version with local display)

The 6 markers ? x below the local display only show information about the status of measurement and are no error displays!

- ? 1: **No current measured value:** The device is searching for a new value. If the search for a plausible level fails for a certain time, "SIGNAL DOWN" appears as error display.
- ? 2: **Signal too strong:** Mean of reflected microwaves is very high. Gain is automatically stepped down.
- ? 3: **Poor spectrum:** Brief showing of this marker has no significance. If permanently on, this may result in uncertain (incorrect) measured values or the error message "NO M.VALUE".
- ? 4: **No measured value as yet:** Evaluable measured values not available after the device has been started up. Measured value automatically set to the level of the tank bottom. This marker disappears when the first valid measured value is obtained.
- ? 5: **Tank bottom:** In tanks with dished bottom, for example, the measuring signal can "disappear" if measurements are carried out near the bottom. The measured value is then automatically set to the level of the tank bottom.
- ? 6: **Measurement frozen:** Device is in the block distance detection (see below).

Simply scaling the current output

1) Drain the tank completely to the 0% marking (= 4 mA) ¹⁾.



2) Press the lower keys (↵ and ↓) down, until the asterisks on the display „TANKHEIGHT|*****“ are replaced by the actual measured distance value ²⁾.

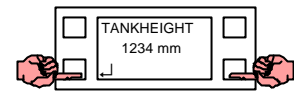

3) Then release and press ↵. In the lower line: “SURE NO?” is displayed.

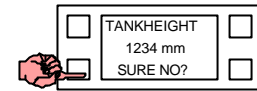

4) If this value is not plausible or the tank is not empty, abort by ↵. Or accept the value by pressing ↑ (“SURE YES?”) and then ↵.

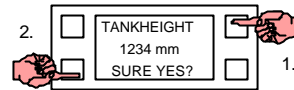

5) Now the tank height is set.

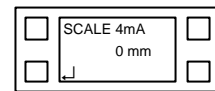

6) In the next step you can also enter this value as 4 mA scaling (0%). Press ↵. In the lower line now: “SURE NO?” is displayed again.

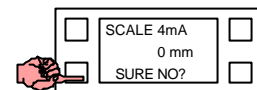

7) If this value shall not be stored, abort by ↵. Or accept this 4mA scaling by pressing ↑ (“SURE YES?”) and then ↵.

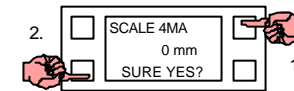

8) Fill the tank to the 100% mark. Use the same procedure for the 100% point = 20 mA only now by pressing the top keys → and ↑ ¹⁾ ²⁾.

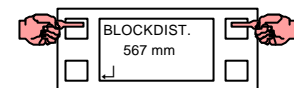

9) First the measured distance can be taken as block distance. After this you can enter or adjust the 20 mA point (100%) according to the actual level.

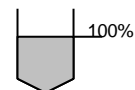

¹⁾ This example was written for the case: current output = level (default). For distance measurement the points 0% (short distance = high level) and 100% (large distance = low level) are exchanged

²⁾ If no reliable measurement is possible “NO ACCESS” is displayed. Abort by pressing ↵

Description of functions

The table on the following 3 pages provides an overview of all parameters that can be set in the configuration menu.

This is followed by more precise explanations of some functions and a typical configuration.

Configuration menu (version 7.00)

Function (Fct.)	Input range	Description
1.0 OPERATION		
1.1 DISPLAY		
1.1.1 FCT.DISP		identical with 3.2.1
1.1.2 UNIT.LENGTH		identical with 3.2.2
1.1.3 UNIT.CONV.		identical with 3.2.3
2.0 TEST		
2.1 HARDWARE		
2.1.1 MASTER		Master hardware test.
2.1.2 DISPLAY		Display hardware test.
2.1.3 STATUS		Status information for Service
2.2 CUR.OUTP.I		
2.2.1 VALUE I	Value display	Display of actual value of the current output.
2.2.2 TEST I	Select 3.6 mA/4 mA/6 mA/... ... 20 mA/22 mA	Output of selected value to the current output. With safety query.
2.4 FIRMWARE		
2.4.1 MASTER	Display	Display of master firmware version.
3.0 INSTALL.		
3.1 BASIS.PARAM		
3.1.1 TANKHEIGHT	Select unit m/cm/mm/ inch/Ft Enter 0.50 ... 20.00 [m]	Enter tank height (see explanatory notes). The unit entered here is also used for all other length entries.
3.1.2 BLOCKDIST	Enter 0.10 [m] ... tank height	Enter block distance = non-measurable range below bottom edge of flange (see explanatory notes).
3.1.3 ANTENNA	Select STANDARD WAVE-STICK	Select antenna type. WAVE-STICK for all Wave-Stick versions, except type "SW" for stillwells. All other = STANDARD.
3.1.4 ANT.EXTENS.	Enter 0.00 [m] ... tank height	Enter length of antenna extension (not for Wave-Stick: set to= 0)
3.1.5 DIST.PIECE	Enter 0 ... 2000 [mm]	Enter length of distance piece above flange (high temp. version = 120 mm).
3.1.6 STILLWELL	Select NO / YES If "YES": enter 25 ... 200 [mm]	Selection: without or with still well. With still well: enter inside diameter in [mm] (compensates different wave speeds in still wells)
3.1.7 REF.OFFSET	Enter -10.00...0...+10.00 [m]	Reference offset is added to measured distance values.
3.1.8 TB.OFFSET	Enter- 100.00...0...+100.00 [m]	Tank bottom offset is added to measured level values.
3.2 DISPLAY		
3.2.1 FCT.DISP	Select LEVEL DISTANCE CONVERSION	Select function of display (value to be displayed). See also explanatory notes.
3.2.2 UNIT.LENGTH	Select m/cm/mm/ inch/Ft/ PERCENT/BARGRAPH	Select unit for length value to be displayed (only for level and distance).

Function (Fct.)	Input range	Description
3.2.3 UNIT.CONV.	Select m3 /l(Liter)/US Gal/ GB Gal/Ft3/bbl/PERCENT BARGRAPH/USER UNIT	Select unit for conversion value to be displayed ("volume table"). (see explanatory notes)
3.2.4 USER UNIT	Text entry 10 characters	Enter user-defined unit for the conversion table.
3.2.5 ERROR MSG.	Select NO/YES	Select whether error messages to be shown in display.
3.3 SIGNAL OUT		
3.3.1 FUNCTION I	Select OFF/ LEVEL /DISTANCE/ CONVERSION/SW.OUT	Select function of the current output.
3.3.2 RANGE I	Select 4-20mA 4-20mA/E3.6 4-20mA/E22	Select range/error status for the current output (hold last value or 3.6 mA/22mA in error status)
3.3.3 SCALE 4mA	Enter -200.00 ... +200.00 [m] 0.00 ... 99999.99 [m ³]	Enter lower measuring range value for the current output (4 mA). (see explanatory notes)
3.3.4 SCALE 20mA	Enter -200.00 ... +200.00 [m] 0.00 ... 99999.99 [m ³]	Enter full-scale range value for the current output (20 mA). (see explanatory notes)
3.3.5 BAUDRATE	Select 1200 Bd	Baud rate for HART® communication (do not change!).
3.3.6 ADDRESS	Enter 0 ... 255	Enter device address. (for HART® multidrop)
3.3.7 PROTOCOL	Select HART /HYCONTROL-PC	Select communications protocol
3.4 USER DATA		
3.4.1 LANGUAGE	Select GB-USA/D/F/I/E/P/S	Select language for the optional display.
3.4.2 ENTRY CODE 1	Select NO/YES	Switch the access lockout on/off. If YES, for every access a 9-digit entry code on the 4 keys is necessary.
3.4.3 CODE 1	Enter code (RRREEUUU)	Enter the entry code for access lockout.
3.4.4 LOCATION	Enter text (8 characters)	Enter a device identifier.
3.5 APPLICAT.		
3.5.1 AUTO TANKH.	Special function	Automatic determination of tank height (see explanatory notes).
3.5.2 EMPTY.SPEC.	Select OFF/ON / RECORD	Recording the profile of the empty tank (empty-tank spectrum) (see explanatory notes).
3.5.3 TIMECONST.	Value 1... 10 ...100 [s]	Enter time constant for measured-value filtering
3.5.4 TRACING.VEL.	Value 0.01... 0.50 ...10.00 [m/Min]	Enter the maximum rate of change in level that can occur in operation.
3.5.5 MULT.REFL.	Select NO/YES	Switch the multi-reflection identifier on/off.
3.5.6 BD-DETECT.	Select NO/YES	Switch the block distance (overflow) identifier on/off (see explanatory notes).
3.5.7 FUNCT. FTB	Select OFF / PARTIAL	Select function of tank bottom tracing system (see explanatory notes).
3.5.8 EPSILON R	Enter 1.1000 ... 8.0000	Enter relative permittivity of product (only for Fct. 3.5.7)
3.5.9 TANKTYPE	Select STORAGE T. / PROC TANK	Select tank type. STORAGE T. = smooth product surface PROC TANK = slightly disturbed product surface

The default settings are marked in the table **bold**.

Explanatory notes

Tank height

The tank height (**Fct. 3.1.1**) for the VG SERIES is defined as the distance between the top edge of the tank connecting flange and the bottom reference point. The bottom reference point is that "point" in the tank on which the microwaves of the VG SERIES hit and from which they are reflected. This may be the tank bottom (symmetrical tank with flat bottom) or the non-horizontal part of the bottom (e.g. tank with dished bottom) or an additionally fitted plate. The VG SERIES cannot measure below this point ("sump" in the tank).

Note: When the tank is completely empty and the tank bottom provides good reflections (flat, not dished bottom!), the tank height can also be automatically determined with the aid of Function **Fct. 3.5.1** AUTO TANKH. Before confirming, check carefully that the proposed tank height is plausible!

Block distance

The "block distance" function (**Fct. 3.1.2**) defines a zone below the top reference point in which measurements are not meant to take place. The value should be at least 10 - 20 cm greater than the length of antenna+antenna extension, or at least 20 cm in the case of the Wave-Stick.

Signals within the block distance are suppressed; a rise in the tank filling above this limit (response threshold) will lead to a measuring result corresponding to a distance = block distance, when **Fct. 3.5.6** BD-DETECT. is switched on.

Scaling of the current output

The scaling of the current output (**Fct. 3.3.3**: level 1 = 4 mA ; **Fct. 3.3.4**: level 2 = 20 mA) should if possible lie within the measuring range (between bottom reference point and response threshold).

By pressing the two upper keys (\rightarrow and \uparrow) or the two lower keys (\leftarrow and \downarrow) at the same time, the 0% setting (= 4 mA) or 100% setting (= 20 mA) can be programmed according to the actual level (see page 9).

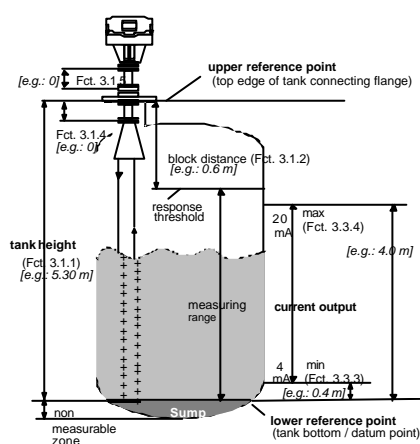

Empty-tank spectrum

To enable the VG SERIES to identify and blank out interference signals, e.g. caused by fixed and moving tank internals, the tank profile (empty-tank spectrum) needs to be recorded once only prior to (initial) start-up. For recording, the tank should be completely empty and all moving parts (e.g. agitators) switched on. If major interference through internals is not expected, recording of the empty-tank spectrum can also be dispensed with, since the factory has already carried out and stored a partial empty spectrum of the flange system.

Empty-tank spectrum recording via display

After selecting menu item **Fct. 3.5.2**, press key →. The display then shows whether the empty spectrum is currently ON or OFF. Then press the ↵ key if no change is to be made, or use the ↑ key to choose between the following options:

- ON: the empty-tank spectrum is (again) switched on and taken into account for measurements.
- OFF: the empty-tank spectrum is not taken into account for measurements, but remains stored in the VG SERIES and can be switched on again at a later date.
- RECORD: the existing empty-tank spectrum is to be deleted and a new one recorded.

After selecting "RECORD": if other parameters had previously been changed, the query "ACCEPT YES" is first made as to whether they are to be stored. In this case, confirm by pressing ↵. To record, use the ↑ key to select one of the following options:

- MAX. VALUES: (only maximum values are taken into account when the empty-tank spectrum is recorded; useful e.g. with "difficult" agitators).
- AVERAGE: (values are averaged; this setting can be used for most applications).

After selecting with the ↑ key, press the ↵ key to select TOTAL or the ↑ key to select PARTIAL.

- When TOTAL is selected, the empty-tank spectrum is recorded over the entire range (tank height).
- If the tank has not been fully drained, the empty-tank spectrum can also be recorded up to a certain distance, in which case the menu item PARTIAL should be selected. When this has been selected, a query takes place by way of the ↵ key concerning the distance value up to which the empty-tank spectrum is to be recorded. The tank area below the current filling level is then excluded from the empty-tank recording. It is recommended to maintain a safety distance of 20 to 30 cm from the actual product distance.

Subsequently press key ↵ to start recording the empty-tank spectrum. The display starts with "200" and counts down to "0". The sign WAIT... is shown in the display. READY appears after approx. 1-3 minutes. Then press key ↵ five times to store the recorded empty-tank spectrum, which is taken into account for measurements.??

Empty-tank spectrum recording via PC-CAT

Connect the VG SERIES and press in the display mode of PC-CAT the key combination Ctrl-L. The type of empty-tank spectrum can be selected by one of the following keys:

- | | | |
|---------------|-----------------|----------|
| 1: Max.Values | 4: Max. Partial | A: Break |
| 2: Average | 5: Avg. Partial | |

Tank bottom tracing mode (FTB)

The VG SERIES includes an additional function for measuring reliably low levels in tanks with flat bottom and poorly reflecting products (low dielectric constant). This tank bottom tracing system (abbreviated FTB) is activated in the vicinity of the tank bottom (max. 20% level). Given higher levels, the normal measuring method is used (reflection from the product surface).

If the measurement jumps to the correct level only after filling above a certain level (approx. 0.3-1.0 m), you can activate the FTB function **Fct. 3.5.7** „PARTIAL“. The relative permittivity ϵ_r of the tank product must be set in **Fct. 3.5.8**. If it is not known, enter the figure of 2.0. Since the exact position of the tank bottom must be known for this process, it is advisable when using the FTB to determine the tank height automatically with an empty tank, using **Fct. 3.5.1**.

Conversion table/Volume table

A table consisting of a maximum of 50 points can be stored in the VG SERIES for non-linear or linear conversion of the level, e.g. into a volumetric value. This table, however, can only be programmed with the PC-CAT program (Fct. 3.7.2).

Sequence for setting parameters (example) (for version with local display)

The following description refers to a storage tank with the parameter examples taken from the illustration in this Section. If the device no longer contains the default parameters, the keystroke combination for entering the numerical values may differ.

Activity	Keys to be actuated	Content of VG SERIES display after activity carried out
Entry into configuration menu	→	Fct. 1.0 OPERATION
Setting the parameter: tank height	↑↑→→	Fct. 3.1.1 TANKHEIGHT
Display of default value	→	10.000 m
Input of tank height "5.30 m"	→↓→5x↑→3x↑	05.300 m
Confirm tank height and move to block distance	↵↑	Fct. 3.1.2 BLOCKDIST
Display default value	→	0.5000 m
Enter block distance "0.60 m"	→↑	0.6000 m
Confirm block distance and move to current output	↵↵↑↑	Fct. 3.3 SIGNAL OUT
Move to lower range value	→↑↑	Fct. 3.3.3 SCALE 4 mA
Display default value	→	+ 00.000 m
Enter lower range value (0.4 m = 4 mA)	3x→4x↑	+ 00.400 m
Confirm lower range value and move to full-scale range value	↵↑	Fct. 3.3.4 SCALE 20mA
Display of default value	→	010.00 m
Enter full-scale value (4.0 m = 20 mA)	2x→↓→4x↑	004.00 m
Confirm full-scale value and move to empty tank spectrum	↵↵↑↑→↑	Fct. 3.5.2 EMPTY.SPEC.
Select: re-record empty spectrum	→↑↑	RECORD
Store changed parameters	↵	ACCEPT. YES
Confirm and select: averaging	↵↑	AVERAGE
Confirm and start recording; then wait for approx. 1-3	↵↵	READY
Confirm and move to tank type	↵7x↑	Fct. 3.5.9 TANK TYPE
Display of default value	→	PROC TANK
Select tank type "storage tank"	↑↑	STORAGE T.
Return to measurement function with confirmation of changed parameters	5x↵	PARAM.CHECK, then START, then meas.val. display

5 Maintenance, error handling

Replacement of the signal converter

Before commencing, note the parameters of the VG SERIES and switch off the power supply!

1. Disconnect all cables from the terminals in the terminal compartment.
2. Remove the 4 Allen screws M (Allen key size 5 mm) and lift off the signal converter. The flange unit (incl. waveguide window) will remain tight even with pressurized tanks.

Caution

On pressurized tanks, do not on any account remove the 4 screws **H** connecting the waveguide window to the VG SERIES flange! **DANGER!**



3. Fit the new VG SERIES converter.
4. Reconnect all cables in the terminal compartment, as described in Section 3.
5. Check against the enclosed report on settings whether the factory-set parameters are correct for your application. If not, reset.
6. Record the empty spectrum, see Section 4.

Important: Make sure that the screw thread of the covers on the terminal and electronic compartments is well greased at all times.

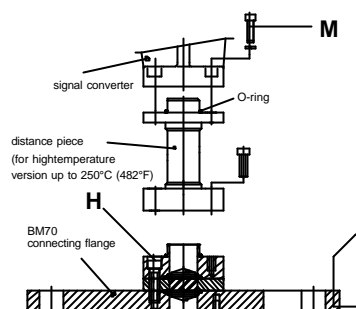

Returning a VG SERIES

The party returning a device is obligated to check and ensure that all cavities in the device are free from dangerous substances (toxic, caustic, flammable, water-endangering), and that a certificate is enclosed with the device confirming that it is safe to handle.

Error display during measurement (only for versions with local display)

When function 3.2.5 "ERROR. MSG." is set to YES, any error occurring during measurement is indicated in the display and alternates with the measured value for as long as the error is present.

In addition, all errors are stored. Press the keystroke combination $\downarrow \uparrow \rightarrow \rightarrow$ to get into the error list. You can page through the list with key \rightarrow , and acknowledge the errors at the end - if required - by "QUIT YES". Press key \downarrow twice to return to the measuring mode.

Fatal errors (FATAL ERROR), that are detected when the device is started up, render operation of the VG SERIES impossible.

6 Safety information

i Hazardous-duty systems

- **Types of protection in the VG SERIES terminal compartment:**
Intrinsically safe"ia"
- Consult the relevant wiring and installation regulations, e.g. VDE 0165, before **mounting, dismantling or making electrical connections** in a hazardous area

Temperature rating of connecting cables:

The temperature rating of connecting cables is dependent on the maximum temperature of the flange:

Version	Max. flange temperature	Cable temperature rating
Without high temperature distance piece	$\leq 100^{\circ}\text{C}$ (212°F)	70°C (158°F)
	$> 100^{\circ}\text{C}$ (212°F)	80°C (176°F)
With high temperature distance piece	$\geq 200^{\circ}\text{C}$ (212°F)	70°C (158°F)
	$> 200^{\circ}\text{C}$ (212°F)	80°C (176°F)

7 Technical data (extract)

Tank height (measuring range)	0.5 to 20 m / 1.6 to 65.6 ft
Measuring accuracy (distance)	from 1m/3ft: $\pm 1\text{cm}/0.4''$; from 5m/16ft: $\pm 0.2\%$
Measured-value resolution	1 mm / 0.04''
Rate of change in level max.	10 m/min / 32.8 ft/min (tracking speed)

Connecting flanges

Horn antenna/Wave-Guide	DIN 2501 DN 50 to DN 200 / PN 6 to PN 64 and higher; Shape C to DIN 2526 or others ANSI B16.5 2" to 8", Class 150 lb or 300 lb, RF
Wave-Stick	DN 50...150 or ANSI 2"...6", dairy DIN 11851 DN 50/65/80, Tri-Clamp 2/3/4", SMS 51/63/76 mm, G 1½"

Max. allowable operating pressure -1 bar (vacuum) to max. 64 bar / 928 psig, depending on version and flange pressure rating. (see name plate)

LP flange system with horn antenna, Wave-Guide or Wave-Stick without flange plate
-1 bar (vacuum) to +2 bar /29 psig

V96 flange system with horn antenna or Wave-Guide:

Connection: nominal dia.		Flange rated pressure							
		PN 16		PN 25		PN 40		PN 64	
DN	inches	bar	psig	bar	psig	bar	psig	bar	psig
80	3	16	232	---	---	40	580	64	928
100	4	16	232	---	---	38	551	55	797
150	6	16	232	---	---	34	493	47	681
200	8	16	232	25	362	32	464	45	652

Wave-Stick: max. 16 bar / 232 psig, temperature-dependent:

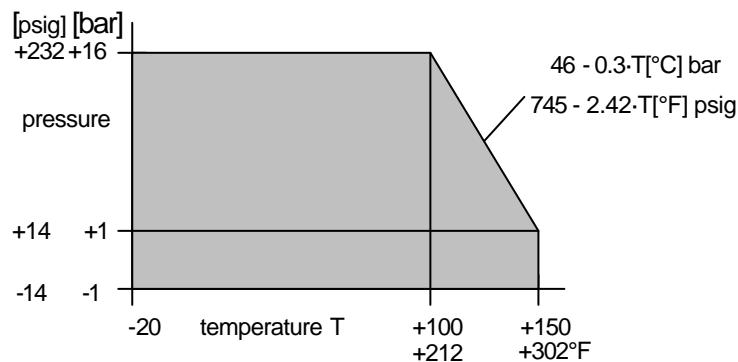

Operating temperature at flange (see also chapter 8)	<u>LP flange system:</u> -20°C (-4°F) to +130°C (302°F) <u>V96 flange system:</u> Basic version: -30°C (-22°F) to +130°C (266°F) Special version: min. -60°C (-76°F) High temperature version, FFKM: max. +250°C (482°F) Kalrez 2035: max. +210°C (410°F) FPM (Viton) or FEP-coated: max. +200°C (392°F) <u>PTFE-Wave-Stick:</u> -20°C (-4°F) to +150°C (302°F), pressure dependent <u>PP-Wave-Stick:</u> -20°C (-4°F) to +100°C (212°F) Unrestricted, provided ambient temperature and flange temperature are within the specified limits Signal converter (Tamb): -40°C (-4°F) to +55°C (131°F)
Product temperature	
Ambient temperature	

Microwaves

Measuring principle	FMCW Radar
Frequency range	X-Band 8.5 - 9.9 GHz
Antenna radiation angle	Type 3: ± 8° Type 4: ± 6° Wave-Stick: ± 9°

Ex-i current output HART® (passive)

Current	4 - 20 mA; without or with error message 3.6 mA or 22 mA
Accuracy and linearity	0.15 %; TC=100 ppm/K
clamp voltage	> 17V (I = 4 mA); > 13V (I = 20 mA)
Digital communication	HART®

Ambient conditions

Environment class	Locations exposed direct to open-air climate, D1 Severity in conformity with EN 60654-1
Protection category (converter)	IP66 / IP67 (equivalent to NEMA 4 and 4X)

Electrical connection

Cable entries:	1 x M 20x1.5 (delivered with 1 cable gland M 20 mm or QUICKON® 2-pole cutter clamp)
Terminals:	Cable cross-section 0.5-1.5 mm ² (AWG 20-16)
U-clamp terminals (for PA and FE) cable cross-section max.	4 mm ² (AWG 12)

8 VG SERIES Level-Radar Type code

Series V96 or LP:

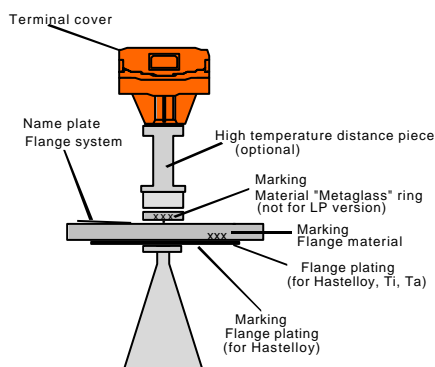

Series WS:

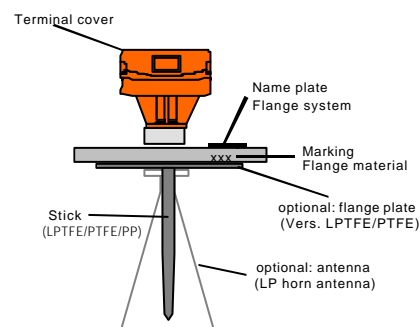

Marking of the **signal converter** (see name plate):

VG SERIES non-Ex version for non-hazardous areas
VG SERIESi / EEx Ex version for hazardous areas,
terminal compartment in Increased Safety „ia“

Marking of the **Flange systems** (see name plate on flange):

..(1)..(2)..... non-Ex version for non-hazardous areas
..(1)..(2)..... – E Ex .(3). Ex version for hazardous areas

(1) *Series*
V96 Flange system V96
(with „Metaglass“ as versions with horn antenna or Wave-Guide)
WS Wave-Stick
(plastics rod antenna or short stick for still wells)
EA Enamel antenna
LP LP version
(with horn antenna or Wave-Guide)

(2) *Materials of the parts in contact with the product*

- **Series V96:**

» Antennas and flanges:

SS Flange and antenna of stainless steel
used material: see marking on flange
HB Flange plating and antenna of Hastelloy B (e.g. B2)
used material: see marking on plating
HC Flange plating and antenna of Hastelloy C (e.g. C4 or C22)
used material: see marking on plating
Ti Flange plating and antenna of Titanium
Ta Flange plating and antenna of Tantalum
Mo Flange plating and antenna of Monel
» gasket material:
FFKM Gaskets of FFKM, e.g. Kalrez™ 4079 or Parofluor™ V8545-75
K2035 Gaskets of Kalrez™ 2035
K1091 Gaskets of Kalrez™ 1091
FPM Gaskets of FPM, e.g. Viton™
FEP Gaskets FEP-coated (FPM core)

- **Series WS**

LPTFE Stick and flange plate of conductive PTFE
PTFE Stick and flange plate of PTFE
SS PTFE stainless steel PTFE, gasket of FFKM
also for version „LP horn antenna“
SS PP stainless steel PP, gasket of FPM (Viton™)

- **Series EA**

EM PTFE Antenna of enamel, sealing of PTFE

(3)

Application conditions, equipment group II
(*explosive atmosphere by gases, vapours, mists*)

1G

equipment category 1, application in Zone 0

2G

(versions V96, EA, or Wave-Stick LPTFE or PTFE with Metaglass)
equipment category 2, application in Zone 1

(free)

(Wave-Stick PP or PTFE without Metaglass, or LP flange system)
Without Ex approval (e.g. LP version)

Limits of temperature at flange:

Version (1)+(2) of the type code	Minimum flange temperature		Maximum flange temperature	
	Standard version	Special version with marking „2.4610“ at the Metaglass ring	Without high temperature distance piece	With high temperature distance piece
V96 ... FFKM	-30°C (-22°F)	-60°C (-76°F)	+130°C (+266°F)	+250°C (+482°F)
V96 ... K2035	-30°C (-22°F)	-60°C (-76°F)	+130°C (+266°F)	+210°C (+410°F)
V96 ... FPM	-30°C (-22°F)	-60°C (-76°F)	+130°C (+266°F)	+200°C (+392°F)
V96 ... FEP	-30°C (-22°F)	-60°C (-76°F)	+130°C (+266°F)	+200°C (+392°F)
WS LPTFE	-40°C (-40°F)	—	+130°C (+266°F)	+150°C (+302°F)
WS PTFE	-40°C (-40°F)	—	+130°C (+266°F)	+150°C (+302°F)
WS SS PTFE	-20°C (-4°F)	—	+130°C (+266°F)	+150°C (+302°F)
WS SS PP	-20°C (-4°F)	—	+100°C (+212°F)	+100°C (+212°F)
LP	-20°C (-4°F)	—	+130°C (+266°F)	—

9 Parameter check list

VG SERIES		Vers.:		device no.	
Menu modified at:					
Fct.	Configuration parameters (extract)				
3.1.1	Tank height	:	:	:	:
3.1.2	Block distance	:	:	:	:
3.1.3	Antenna	:	:	:	:
3.1.4	Antenna extension	:	:	:	:
3.1.5	Distance piece	:	:	:	:
3.1.6	Stillwell / diameter	:	:	:	:
3.1.7	Reference offset	:	:	:	:
3.1.8	Tank bottom	:	:	:	:
3.3.1	Current output, function offset	:	:	:	:
3.3.2	Current output range/error	:	:	:	:
3.3.3	Min. current scale	:	:	:	:
3.5.2	Empty spectrum	:	:	:	:
3.5.3	Time constant	:	:	:	:
3.5.4	Tracking speed	:	:	:	:
3.5.5	Multiple reflections (yes/no)	:	:	:	:
3.5.6	Block distance ident (yes/no)	:	:	:	:
3.5.7	Function FTB	:	:	:	:
3.5.8	Epsilon R	:	:	:	:
3.5.9	Tank type	:	:	:	: