

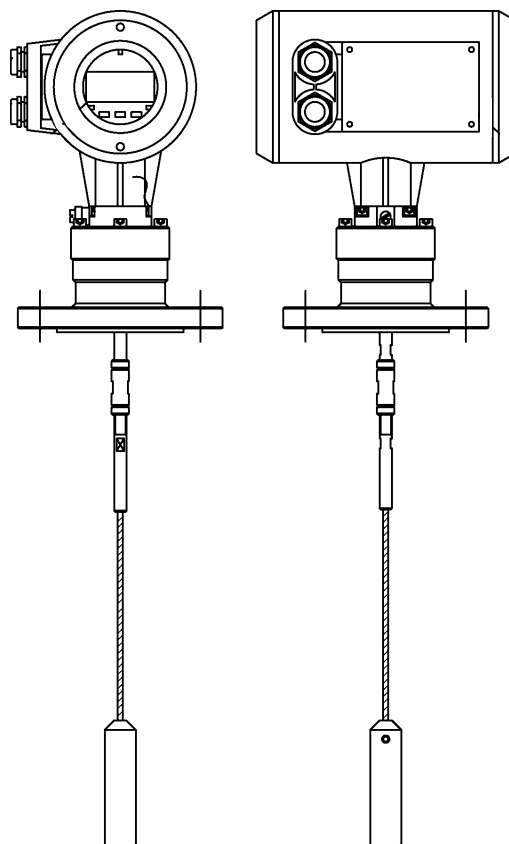

Reflex VF Series Extended Range TDR VF04

Installation Instructions



Hycontrol Limited, Larchwood House, Orchard Street, Redditch, Worcestershire, B98 7DP.
Tel: + 44(0)1527 406800 Fax: + 44 (0)1527 406810
Email: sales@hycontrol.com Website: www.hycontrol.com

Contents

1	Mechanical installation	6
1.1	Handling and storage	6
1.1.1	Avoiding blows	6
1.1.2	Avoiding bending	6
1.1.3	Avoiding cable kinks or fraying.....	6
1.2	Installation restrictions.....	7
1.3	Mounting on a tank.....	7
1.3.1	Installation instructions: General notes	7
1.3.2	Installation instructions: Nozzle.....	7
1.3.3	Installation instructions: Gauge - all applications	11
1.3.4	Installation instructions: Gauge - liquid applications	12
1.3.5	Installation instructions: Gauge - solid applications	13
2	Electrical Connections	15
2.1	Insulation rating	15
2.2	Electrical installation instructions	16
2.2.1	Wiring general notes	16
2.2.2	Wiring connections	17
3	User Interface	21
3.1	Power On and self-test mode.....	21
3.2	Local user interface	21
3.3	Status Markers	22
3.4	Fault clearing	22
4	VF04 technical data	23
4.1	Technical data	23
4.2	VF04 Equipment Architecture	25
4.3	Probe measurement limits.....	27

General advice on safety



The device will normally weigh between approx. 11 kg / 25 lb and 35kg / 77 lb. Carry the device using two people, lifting it by the flange holes and supporting the probe. Lifting gear may also be used but no attempt should be made to lift the device by the probe.

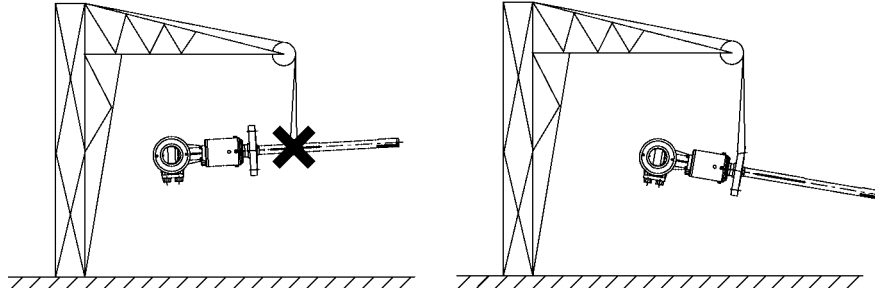

Range of applications

The VF04 TDR Level gauge measures the level and volume of liquids and liquid gases. It can also measure the level and volume of pastes, powders, slurries and granular products.

The VF04 also permits continuous and simultaneous measurement of liquid level and interface of two liquids.

For the storage of volatile products, such as water and carbon disulphide tanks, the VF04 can also be equipped with a probe (type G) to measure the interface with a top mounted probe: this avoids the resultant safety issues of installing a gauge under the tank.

Principal gauge components

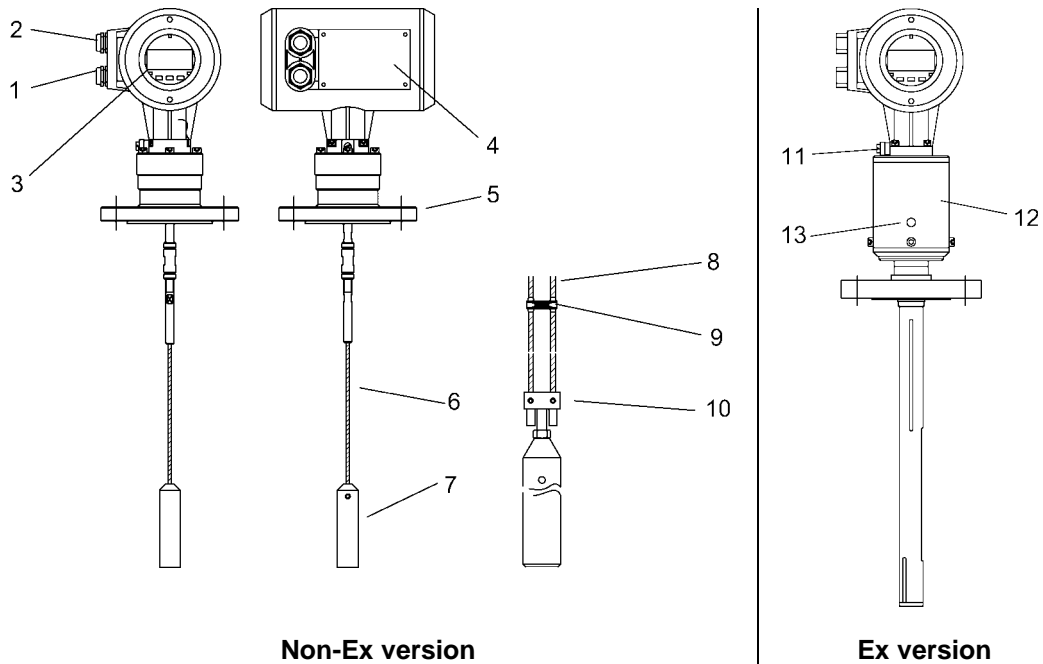

- 1 Cable entry (output)
- 2 Cable entry (power supply)
- 3 Local user interface (display screen, buttons and magnetically-actuated hall sensors)
- 4 Nameplate (see diagram on the following page)
- 5 Flange
- 6 Single cable probe
- 7 Counterweight
- 8 Twin cable probe
- 9 Spacer
- 10 Short-circuit
- 11 Equipotential bonding system connection (Ex)
- 12 Isolating chamber – separates electronics housing from hazardous products
- 13 Pressure release plug (1 bar or 14.5 psi limit) and vent

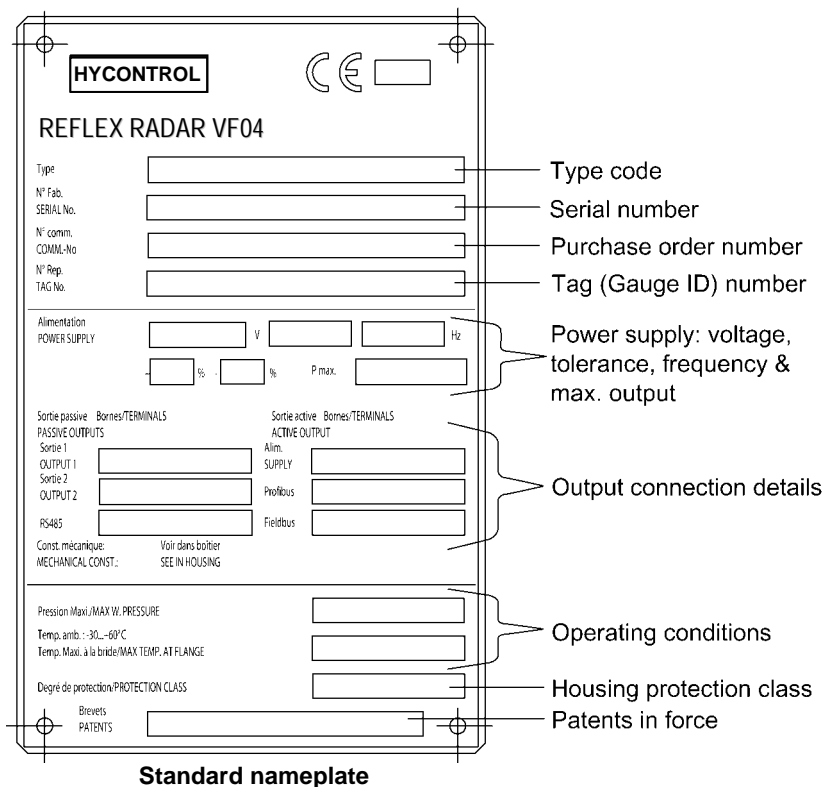

Items supplied

- signal converter connected to a cable, coaxial or rod signal guidance probe
Optional: remote extension with wall support, sunshade (with fastening material in each case)
- bar magnet for operator control / parameter assignment (only in version with local display)
- wrench for the covers

Documentation supplied

- installation instructions: detailed user manual and reference book.
- approval documents, unless reproduced in the installation and operating instructions.

Product liability and warranty

The VF04 TDR level gauge is designed solely for measuring the distance, level, interface and volume of liquids, pastes, slurries, solids and particulate materials.

The VF04 TDR level gauge does not form part of an overfill protection system as defined in WHG. Special codes and regulations apply to its use in hazardous areas.

Responsibility as to suitability and intended use of these level gauges rests solely with the user.

Improper installation and operation of our level gauges may lead to loss of warranty.

In addition, the "General conditions of sale", found on the back of the invoice and forming the basis of the purchasing contract, are applicable.

If you need to return the device to the manufacturer or supplier, please refer to the information given at the end of this manual.

1 Mechanical installation

1.1 Handling and storage



Caution :
The probe is a critical gauge component.
Do not damage– Handle with care!!!

Avoiding blows

Avoid hard blows, impacts and jolts when handling the VF04.

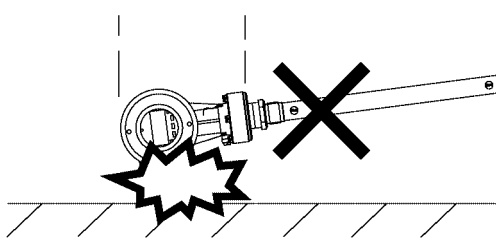

Caution : fragile electronics

Avoiding bending

Rod/ Coaxial probes: support the probe to avoid bending.

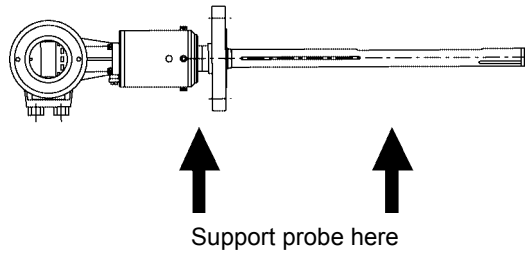

Avoiding cable kinks or fraying

Do not coil the cable less than 400mm / 16" in diameter. Cable kinks or fraying will cause measurement errors.

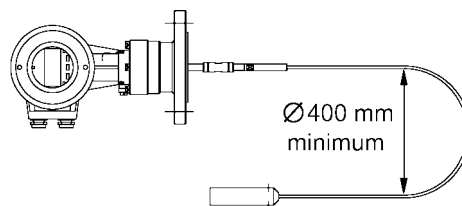

Installation restrictions

Hazardous-duty systems (Ex, FM...):

- refer to the supplementary instructions for gauges approved for use in hazardous locations before installation.
- check that the flange, gasket and probe materials are compatible with the product. Read the information given on the converter nameplate, the flange markings and specifications in the approval certificates.

Mounting on a tank

Installation instructions: General notes

The fitter should give some thought to tank fittings and shape:

- nozzle position in relation to the tank walls and other objects inside the tanks
(Warning : this free area will depend on the probe type selected, refer to section 1.3.2)
- type of tank roof , i.e. floating, concrete, integral, etc; and base, i.e. conical,etc.

Installation instructions: Nozzle

Nozzle height



Recommendation (especially for single probes and powder applications):
Do not fit a nozzle longer than its diameter.

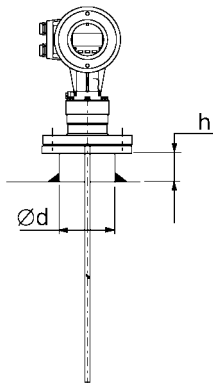

$h \leq \varnothing d$, where h = nozzle height and d = nozzle diameter.

Contact HYCONTROL if this relationship cannot be respected.

Nozzles extending into tank



Caution:

Do not use nozzles that extend into the tank. This will block the emitted pulse.

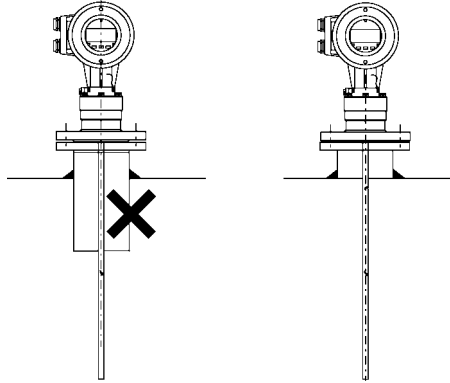

Process connection

For the gauge to make accurate measurements:

- the tank process connection must be level.
- ensure a good fit with the gauge process connection
- the tank roof should not deform under the weight of the gauge

Discontinuities that influence the probe's EM (electromagnetic) field

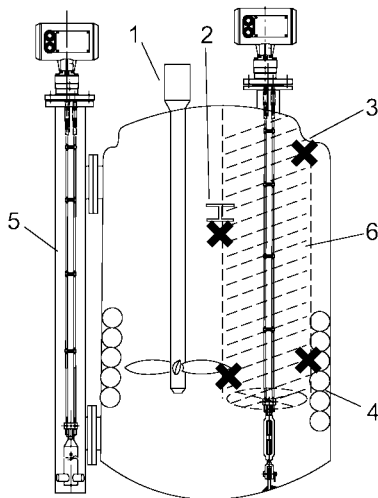

- 1 Agitator
- 2 Support beam perpendicular to the pulse direction
- 3 Abrupt changes in tank cross section
- 4 Heating tubes
- 5 Alternative solution: reference chamber - electromagnetic field is contained within chamber. See also notes in section.
- 6 Gauge electromagnetic field : Any intruding metallic object will be detected in this zone if perpendicular to the emitted pulse direction.

X = Do not fit the process connection near to these objects.

Probe Type	Recommended minimum distance of probe from objects inside the tank in millimetres (inches)
Single (types F, H and K)	300 (12)
Twin (types A, B, G and L)	100 (4)
Coaxial (type D)	0 (0)

Diagram 12: Electromagnetic field shape around probe, by type (not to scale)

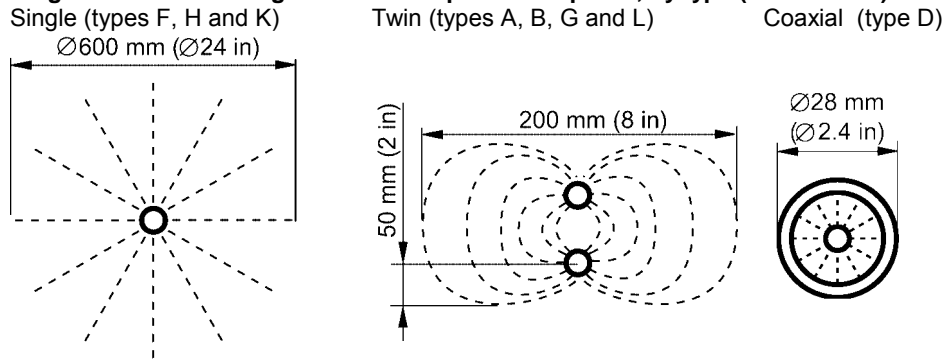

No beam angle for any probe type.

For clean applications only :

Coaxial (type D) probes may be used close to or touching objects or walls as the EM field generated by the probe is contained within the probe's outer sheath.

Process connection and entry pipe



Caution:

Do not put the nozzle close to the entry pipe. Pouring the product directly onto the probe will give false readings. Install deflector plate if impossible to distance gauge from entry pipe.

Install far from the entry pipe...

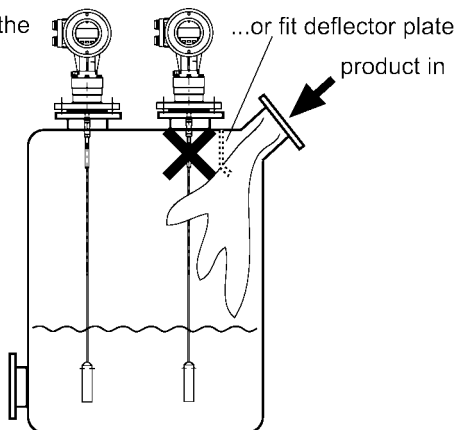

Stilling wells

Tanks with floating roofs for petrochemical applications: see also section 1.3.4.

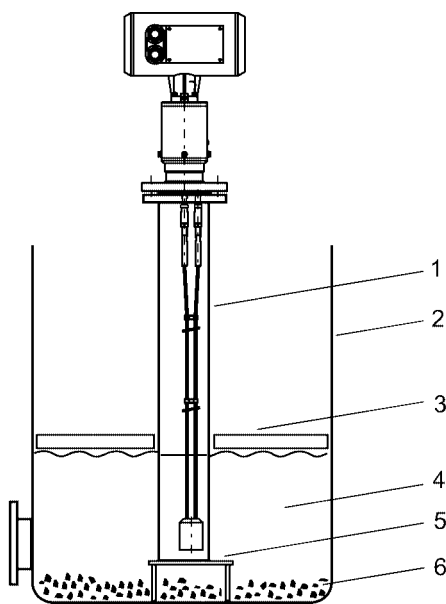

- 1 Stilling well
- 2 Tank
- 3 Floating roof
- 4 Product (petroleum applications)
- 5 Well fixed to tank base (no roof deformation)
- 6 Sediment

1.3.3 Installation instructions: Gauge - all applications

VF04 gauges are designed to be mounted on a suitable process connection on a tank or sump. Install the gauge using two people to avoid damaging the probe. Support the housing and the probe.

Gauge installation: Cable probe types: B, H, K & L



- 1 **Caution :**
Do not over-bend probe!
- 2 **Inserting the probe:**
hold more than one metre above the opening to avoid cable bending.

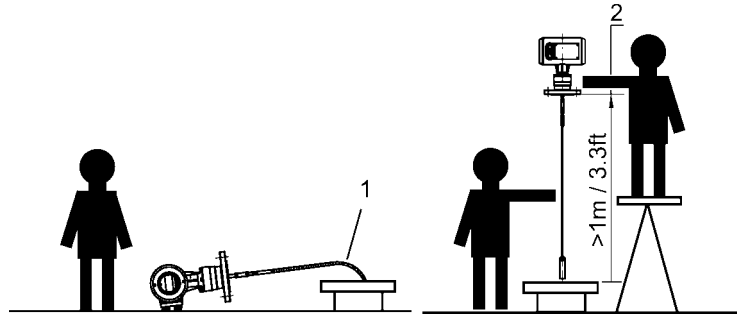

Outdoor sites

Fit a sunshade on the gauge for open-air installations: this is supplied on demand. The ambient temperature limits are given below.

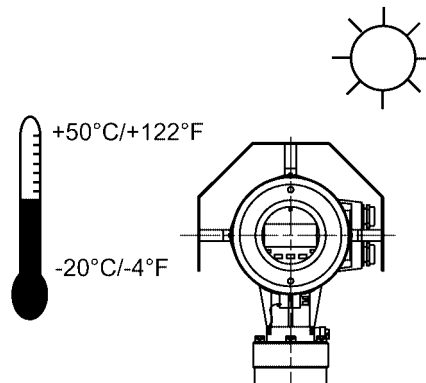

Cable probes: entanglement and straightness

The cable must be straight once inserted into the tank. The cable counterweight should not touch the bottom of the tank. The cable must be far from objects (e.g. agitators) to avoid entanglement.

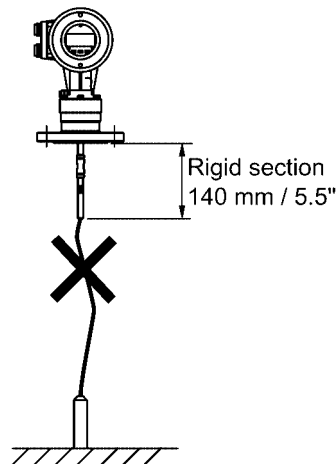

1.3.4 Installation instructions: Gauge - liquid applications

This sub-section covers the installation of each probe type and recommendations for liquid applications.

Special attention should be paid to probe bending in agitated products (tanks with agitators, ships' tanks and eddy currents) in liquid applications. See also diagram on the following page.

Probe bending in agitated products: recommended solutions

Probe (Type)	Supports and fastenings	Stilling well installation*
Twin rod (A)	Weld a 45mm / 1.8" internal diameter tube on the bottom of the vessel, insert the two rods if short circuit is present.	Possible. On-site calibration may be required to maintain accuracy. Repeatability is unaffected.
Twin cable (L)	Unscrew counterweight*** and fit an anchor with an M10 x 1 (Ø4mm cable) thread (i.e. turnbuckle, spring ring or hook). CAUTION: 6 Nm / 4.4 lbf . ft maximum torque	Centre the probe with plastic spacers supplied by HYCONTROL to avoid contact between the tube wall and the probe.
Single rod (F)	Weld a 12mm / 0.5" internal diameter tube on the bottom of the vessel, insert the rod****.	Possible. 50 mm / 2" minimum diameter chamber. Contact HYCONTROL for assistance.
Single cable (H)	Unscrew counterweight*** and fit an anchor M10x1 (Ø4mm cable) thread: turnbuckle, spring ring or hook. CAUTION: 4 Nm / 2.9 lbf . ft maximum torque	Possible. 50 mm / 2" diameter minimum. Contact HYCONTROL for assistance**.
Coaxial (D)	Weld a 30-32mm / 1.2" internal diameter tube on the bottom of the vessel, insert the tube. A probe may be fixed with braces.	Unnecessary: probe unaffected by nearby objects.

* Reference (bypass) chamber or stilling well.

** Spacers supplied by HYCONTROL.

*** Threaded hole in base of counterweight may also be used for anchoring.

**** Contact HYCONTROL. A factory menu function may need to be changed.

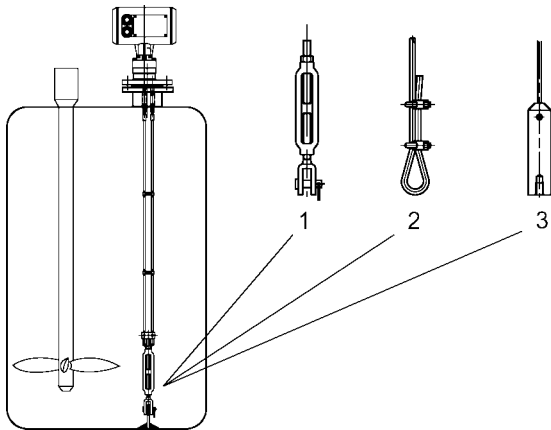

- 1 Turnbuckle
- 2 Chuck for type H Ø4 single cable probe
- 3 Counterweight with threaded base
- 4 Avoid play between tube and probe
- 5 Hole in welded tube for drainage

Anchoring twin rod and coaxial probes

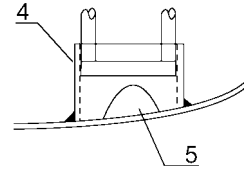

1.3.5 Installation instructions: Gauge - solid applications

False readings:

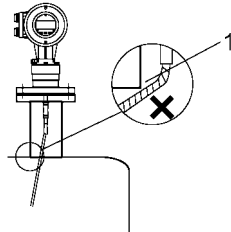

- 1 Do not let probe touch the side of the nozzle

Conical silo nozzles, False readings and traction on the cable probes



Caution

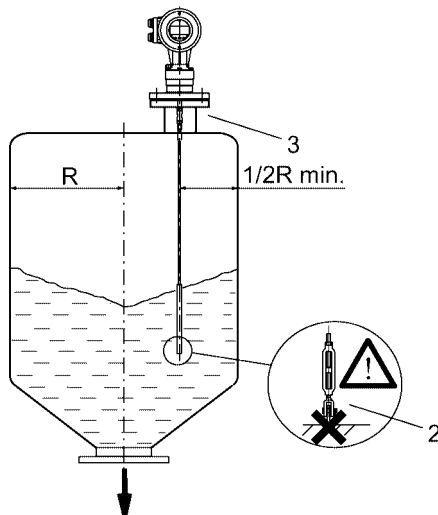

- 2 **High traction forces :**
We recommend that the probe should not be anchored to avoid excessive traction loads on the cable.
- 3 **Bending and traction:**
Position the connection on the roof at $\frac{1}{2}$ radius of the tank and with minimum nozzle height. This will avoid damage due to bending and traction during emptying.

Traction forces during emptying cycles for powder applications

Traction load is dependent upon the height and shape of the tank, product particle size & density, and the rate at which the tank is emptied. The table below gives the load at which cable probes will break.

Cable maximum design loads (traction)

Probe	Maximum Load
Type K : Single cable Ø8 mm / Ø 0.3"	3.5 T / 7700 lb
Type B : Twin cable Ø6 mm / Ø 0.2"	3.6 T / 7900 lb (1.8 T per cable)

Traction on cable according to product (approximate value in metric tons & pounds)

Material	Probe used	Probe Length		
		10 m / 32.8 ft.	20 m / 65.6 ft.	30 m / 98.4 ft.
Cement	Single cable Ø8 / Ø 0.3"	1.0 T / 2200 lbs	2.0 T / 4410 lbs	3.0 T / 6620 lbs
Flyash	Single cable Ø8 / Ø 0.3"	0.5 T / 1100 lbs	1.0 T / 2200 lbs	1.5 T / 3300 lbs
Wheat	Single cable Ø8 / Ø 0.3"	0.3 T / 660 lbs	0.6 T / 1320 lbs	1.2 T / 2650 lbs
PE granules	Twin cable Ø6 / Ø 0.2"	0.2 T / 440 lbs	0.6 T / 1320 lbs	1.0 T / 2200 lbs

Electro static discharge (E.S.D.)

VF04 Standard and Ex gauge electronics are normally shielded up to 16KV against E.S.D.*.

*For non-Ex powder applications, VF04 probes are protected up to 32 kV.



Note:

E.S.D. cannot be solved by VF04 E.S.D. protection. It is the customer's responsibility to avoid E.S.D. by connecting the tank, product and probe installation to ground.

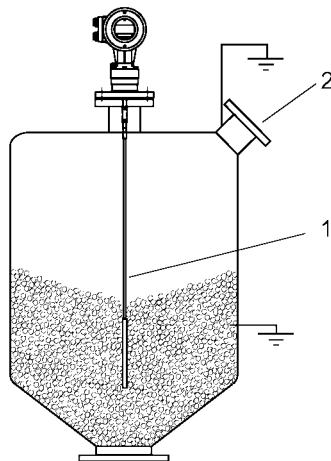

1



Danger of injury

The probe may become electro statically-charged during operation; earth the probe by pushing it against tank wall with a suitably isolated tool just before touching it to avoid receiving a shock.

2 Earth the entry pipe and product.

Product deposits on the nozzle and probe

Product build-up can occur under the nozzle: this may weaken the pulse. Avoid cavities that permit the build-up of deposits.

Tank roof deformation

Tank roofs should support loads of at least 3.5 tonnes / 7700lb for gauge installations using type K single cable probes and 3.6 tonnes / 7900 lb for gauge installations using type B twin cable probes without deformation.

2 Electrical Connections

2.1 Insulation rating

The gauge transmitter electrical insulation conforms to IEC 1010-1. Please note the information below concerning each rating category.

Category	Rating	Comments
Power supply	overvoltage category III	The gauge does not have an integrated switch or circuit-breakers. These elements must be installed in conformance to local regulations and EU Low Voltage Guidelines and to properly isolate the equipment when necessary. Note that this is not obligatory for instruments with 24 V power supply boards. 4 to 6.3A time lag fuses are recommended for external installation. Fuses must be installed on every electrical conductor for the system to conform to current regulations. Note that the active phase conductor, L, is protected by an internal fuse: the neutral conductor, N, is not.
Output circuit	overvoltage category II	Fuses are unnecessary.
Insulation	contamination level 2	The contamination level refers to the protection of internal elements of the signal converter. Rated IP67 (equivalent to NEMA 6-6P) against ingress of water and other foreign bodies. Note that the gauge can operate in contamination level 4 conditions if installed correctly.
Protection	class 1	

Galvanic isolation of terminals

The gauge conforms to the following standard and E.U. Directive:

Standard/Directive	Description
EN (IEC) 61010-1	Safety requirements for electrical equipment for measurement, control and laboratory use (low tension)
72/23/EEC	Council Directive of 19 February 1973 on the harmonisation of the laws of Member States relating to electrical equipment designed for use within certain voltage limits (low voltage)

The VF04 gauge outputs are isolated from the power supply and ground in accordance with the regulations given above. An external barrier is unnecessary.

2.2 Electrical installation instructions

2.2.1 Wiring general notes



Read these instructions carefully

Wiring must comply with any existing local regulations. Use appropriate wiring methods, conduits and fittings to maintain a NEMA 6-6P / IP67 rating.

1. Always disconnect the mains power supply before opening the housing,
2. unscrew the terminal compartment using the special wrench provided,
3. use the top cable entry port for the power supply (see “Principal gauge components”),
4. use a metal cable gland for input power leads to minimise RFI (radio frequency interference) / EMI (electromagnetic interference) effects,
5. use a reinforced cable for the outputs,
6. do not cross or loop wires in the signal converter wiring box,
7. do not kink cables close to the glands. Cover with a metallic sheath at this point if necessary,
8. make U-bends in the cable to provide water with run-off points,
9. earthing the device shall be done according to the local applicable installation standards (EN 60079.14 in Europe),
10. and make sure that the cover thread in the housing is well greased and the O-ring is in good condition before replacing the cover.



Shutting off the power supply: non-hazardous zones

Remember to disconnect the power supply before opening the housing.



Shutting off the power supply: hazardous zones

Wait before opening the housing cover. Refer to Supplementary Installation and Operating Instructions for the VF04/Ai KEMA 03 ATEX 2572X Gauge for the time required.

2.2.2 Wiring connections

Open the signal converter housing rear cover, using the plastic wrench supplied. The terminal connections are labelled. The standard connections are shown below:

Before starting to wire:

- check that the power supply corresponds to the power board installed and
- check which output option you have selected.

This information will be indicated on the underside of the rear housing cover and on the gauge nameplate.

Terminal layout: non – Ex version

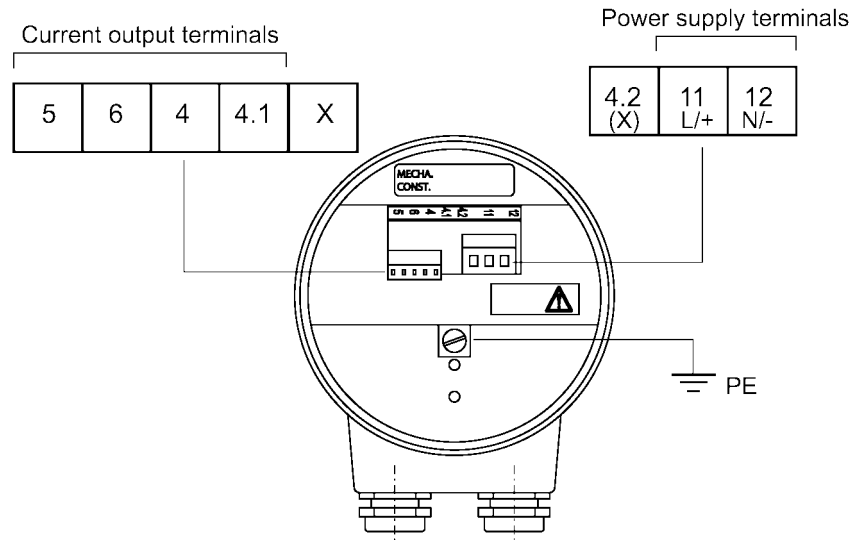

X = Terminal not used

(X) = Terminal not used except for RS485 outputs

Ensuring a good contact and protection of wire strands

Local regulations concerning electrical wiring must be followed and obeyed. If no details are given, we recommend :

- crimped metal sheaths over the wire strands
- power supply cables should be rated for 500 V at least, with a cable diameter of 0.5 to 1.5 mm / 0.02" to 0.06" (non-Ex applications only).
- the output current cable diameter should be from 0.5 to 0.75 mm / 0.02" to 0.03"

PE Ground Terminal notes

The internal earth connection shall be used according to local applicable installation standards, in Europe the Low voltage Standard prescribes the connection of the yellow/green cable in case of 230VAC.

Terminal layout: Ex version

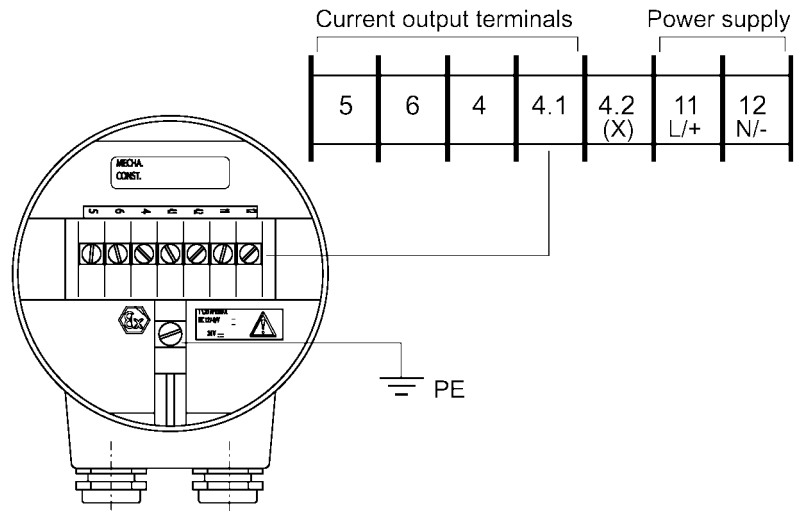

(X) = Terminal not used except for RS485 outputs

Wiring the gauge for use in hazardous areas (Ex & FM)

Use the correct wires and spade tags for terminal connections as specified in the Supplementary Installation and Operating Instructions for the VF04 A/Ai KEMA 03 ATEX 2572X Gauge.

PE Ground Terminal notes

The internal earth connection shall be used according local applicable installation standards, in Europe the Low voltage Standard prescribes the connection of the yellow/green cable in case of 230VAC.

Options, power supply

The type of power supply to be used will be indicated on the gauge nameplate.

1. 100 – 240V AC -15%/+10% ; Power output : 9VA
2. 24 V AC/DC -15%/+10% ; Power output : 9VA

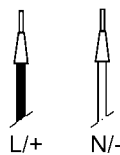
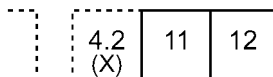

Options, output

The output wires should be wired to the gauge terminals according to the type of output selected when the order was placed. The type of output supplied will be indicated on the gauge nameplate and a sticker on the inside of the housing rear cover. The principle output options are shown below:

- 1 passive output (passive = external power source used for measurement output)

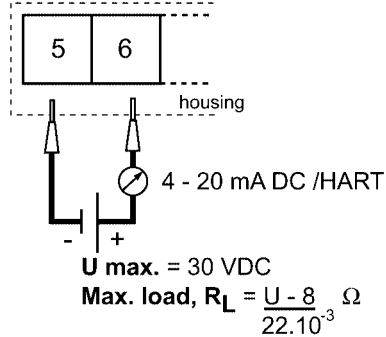

- 1 active output (active = internal power source used for measurement output)

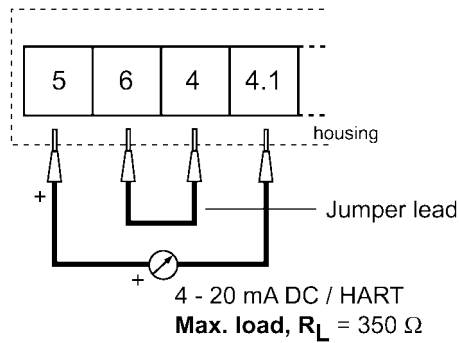

- 2 passive outputs

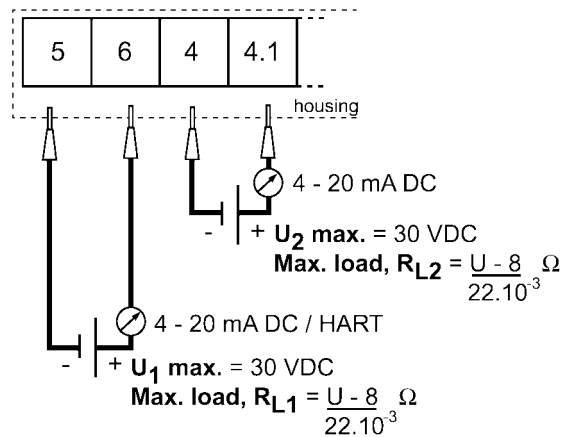

- 1 RS 485 output
with / without optional analogue current output for direct readings**

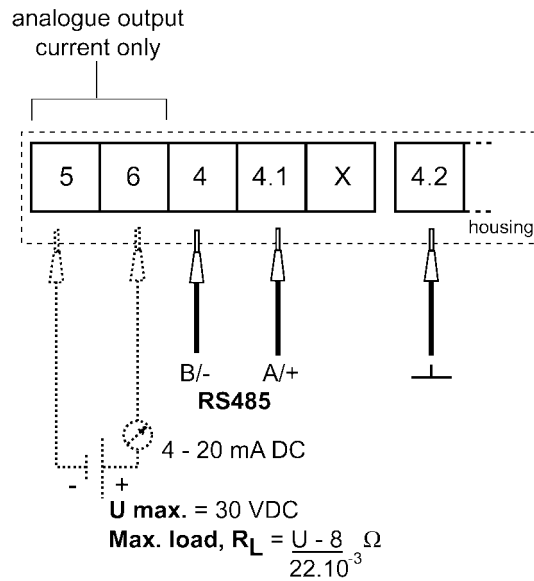

- PROFIBUS PA output & optional*
with / without optional analogue current output for direct readings**

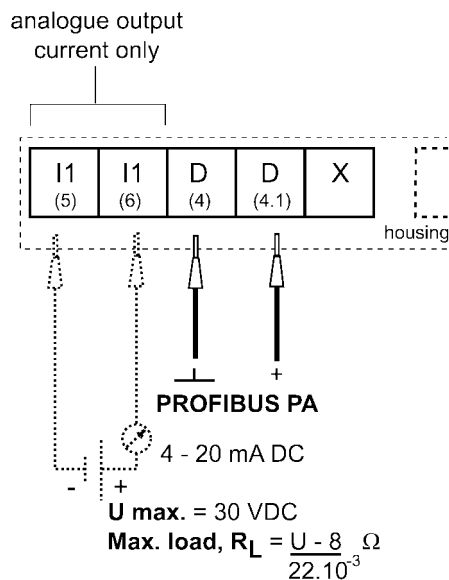

* VF04 device management: the following is delivered with a PROFIBUS PA-output device:-

1. GSD file: providing a device communication features list and an
2. EDD file: providing a description of device application features.

** must be specified in customer order

3 User Interface

The VF04 may be configured and operated using a user interface set into the signal converter housing or a remote link.

3.1 Power On and self-test mode

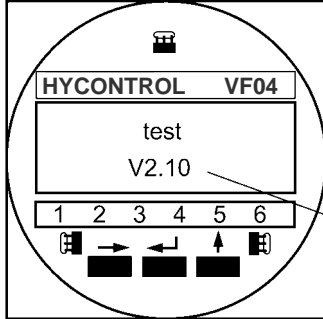

The VF04 automatically self-tests once connected to a power source. The screen readout shown on the left will be displayed. This test takes from 20 seconds to 1½ minutes to complete. The local display will then switch over to the operation mode display shown below.

Firmware release programmed into the EPROM (Electrically Programmable Read Only Memory)

3.2 Local user interface

The VF04 Local user interface is simple to use. It has three push-buttons, three magnetically-keyed sensors for configuring the gauge without removing the front cover in hazardous zones and a three-line LCD (Liquid Crystal Display) screen at the front of the signal converter housing.

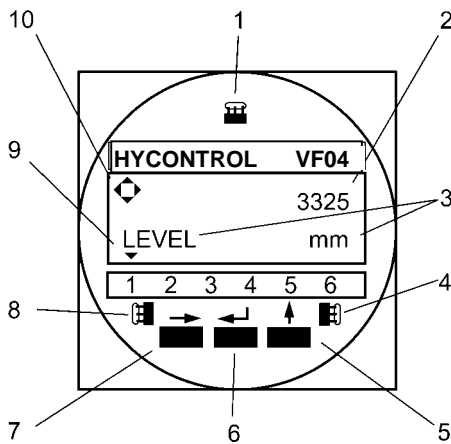

Note: the display screen will go blank below -20°C / -4°F but data can still be displayed if the instrument is connected to a computer with PC STAR or other remote link.

- 1 **ENTER Hall Sensor:**
Keyed using a bar magnet. As item 6.
- 2 **First Display Line:**
Operating mode- measurement value
Configuration mode- function number
- 3 **Second Display Line:**
Operating mode- item measured and units
Configuration mode- function definition
- 4 **UP Hall Sensor:**
Keyed using a bar magnet. As item 5.
- 5 **Press the UP push-button:**
 - To increase the value of a selected digit
 - For password definition : code U ↑
or
- 6 **Press the ENTER push-button:**
 - To go back a step in the menu
 - To validate data entered
 - For password definition : code E ↵
or
- 7 **Press the RIGHT push-button:**
 - To enter configuration mode
 - To move cursor right in configuration mode
 - For password definition : code R →
or
- 8 **RIGHT Hall Sensor:**
Keyed using a bar magnet. As item 7.
- 9 **Status Markers:**
See the next page for details.
- 10 **Key register symbol:**
 - ◊ Enter pressed
 - ↑ Up pressed
 - Right pressed

3.3 Status Markers

This line of numbers identifies six types of errors by means of a triangular indicator over the number concerned - see item 9 on the preceding page.

Status marker number	Error / Status message	Result and action
▼1	No initial pulse detected	See section 3.4: Fault clearing.
▼2	No level reflection detected	See section 3.4: Fault clearing.
▼3	Level measurement frozen	Output and indication frozen; search initiated to redetect level: if no reflection is registered then Status marker 2 is activated.
▼4	No interface reflection found	See section 3.4: Fault clearing.
▼5	Interface measurement frozen	Output and indication frozen; search initiated to redetect interface. If no reflection is found, Status marker 4 is activated.
▼6	Output communication failure	Contact your local HYCONTROL Service Department.

3.4 Fault clearing

Event	Fault	Action
General Operation		
Local Display : Status Marker 1 displayed	The High Frequency board is not sending a pulse. Reason: it may have been damaged by electrostatic discharge.	Contact a HYCONTROL- authorised service centre. The electronics package may need to be replaced.
Local Display : Status Markers 2 or 4 displayed	The instrument has lost the level (marker 2) or interface (marker 4) signal, has searched in a pre-defined zone and has not yet found the return pulse.	
	Reason: The product may have risen into the dead zone and has dropped below the threshold due to readings from the flange.	Empty tank below dead zone and check the measurement*.
	Reason: The product level may be at zero (tank empty).	Refill tank above minimum level and check the measurement*.
Local Display : Status Markers 3 and/ or 5 displayed	The display is frozen. Reason: The pulse has dropped below the threshold, whereupon the gauge opens a search window / zone. If no reflection is found, Status Marker 2 (or 4 for interface) will be displayed. Marker 3 is also displayed if PC-STAR is connected and the F7 graphics function has been selected.	Empty tank below dead zone and check the measurement. If the signal is not detected then modify the threshold as shown in section 3.4.6 of the VF04 Handbook.
Electrical Connections and Communication Output		
The display does not work.	Instrument is wired to the wrong voltage : fuses have blown.	Replace the power supply fuse, F1, as shown in section 4.2.2 of the VF04 Handbook.
	If the ambient temperature is below -20°C/-4°F, LCD does not work	Consider using a PC-equipped with HYCONTROL PC-STAR software if operating in a general purpose area.

4 VF04 technical data

4.1 Technical data

Input

Measured variable	Distance, level, liquid interface and volume
Measurement range	Variable according to probe type, see Equipment architecture, section 4.2
Blocking Distance	Variable according to probe type, see Probe measurement limits

Output

Analogue	4 – 20 mA, 1 passive output (as standard)
	Load
	Active outputs 350 Ω maximum
	Passive outputs (U-8)/22.10-3 Ω
	Temperature drift <100 ppm / K
	Resolution $\pm 3 \mu\text{A}$
Digital	HART [®] protocols (as standard). Profibus PA output also available on demand.
Error signal	Status markers and text messages via local display or remote interface.

Performance Characteristics

Accuracy

Level measurement	Liquids when probe length, L < 6 m / 20 ft.* $\pm 5 \text{ mm} / \pm 0.2''$ Optimised with appropriate on-site calibration $\pm 3 \text{ mm} / \pm 0.12''$ Liquids when probe length, L > 6 m / 20 ft.* Additional error above 6m: $\pm 0.02\%$ of distance measured Solids (powders / granulates)** $\pm 20 \text{ mm} / 0.79''$
Interface measurement	Liquids (with minimum layer of 100 mm / 4'', ***) $\pm 10 \text{ mm} / 0.4''$ with configured and stable ϵ_r value
Repeatability	$\pm 1 \text{ mm} / \pm 0.04''$
Resolution	$\pm 0.3 \text{ mm} / \pm 0.012''$
Warm-up time	20 seconds to 1½ minutes (self-test before first reading)
* test medium: water ($\epsilon_r=80$)	** test medium: cement ($\epsilon_r=3$) *** test medium: oil ($\epsilon_r=2.4$)

Test conditions

Ambient temperature	$+20^\circ\text{C} \pm 5^\circ\text{C}$ ($+68^\circ\text{F} \pm 9^\circ\text{F}$)
Ambient air pressure	1013 mbar abs. $\pm 20 \text{ mbar} / 14.69 \text{ psig} \pm 0.29 \text{ psi}$
Relative air humidity	60% $\pm 15\%$
Minimum ϵ_r of target	80 - coaxial probe : water surface - single probe : $\text{Ø}0.8\text{m}$ ($\text{Ø}31.5''$) metal plate - twin probe : metal block "short circuit"
Flange diameter	$> 300 \text{ mm} / 11.81''$ *
Distance to obstruction	$> 1 \text{ m} / 3.28'$
* not for coaxial probe.	

Environment

Ambient temperature	-20°C to $+50^\circ\text{C}$ / -4°F to 122°F
Storage temperature	-40°C to $+85^\circ\text{C}$ / -40°F to 185°F
Protection	IP 67 (US equivalent: NEMA 6 – 6P)

Power supply

Option 1	24 V DC / AC, +10%/-15%, Power used : 9W
Option 2	100 – 240 V AC, +10%/-15%, Power used : 9W

Process

Process temperature, flange	-30 to +150°C / -22°F to 298°F, option 200°C / 392°F See VF04 Ai Supplementary Instructions for Ex values.
Process pressure, standard	-1 to + 40 bar / -14.5 to 580 psig
Process pressure, maximum admissible	100 bar / 1469 psig @ 20°C / 43°F with SS 316 flange, with Ex approval (2G or 2D category equipment only)

Dielectric constant ϵ_r : Measurement mode and probe type limits**Direct mode**

Level measurement	Coaxial (D)	$\epsilon_p \geq 1.4$
	twin probes (A,B,G&L)	$\epsilon_r \geq 1.8$
	single probes (F,H&K)	$\epsilon_r \geq 2.1$
Level and interface measurement*	Twin rod (A), coaxial (D) & twin cable (L)	$\epsilon_r (\text{interface}) \geq \epsilon_r (\text{level})^2$

* The minimum layer is 100 mm and is dependant on the dielectric constant, ϵ_r . This has been determined under test conditions using water ($\epsilon_r=80$) and oil ($\epsilon_r=2.4$).

TBF mode

Level measurement	All except D & G	$\epsilon_r \geq 1.05$
-------------------	------------------	------------------------

Human interface

Communication, standard	HART® protocols installed on first output. Automatic recognition and configuration by gauge. Information displayed via local display (integral or remote), PC or HART® handheld communicator (HHC). Point-to-point: 1 gauge connected to PC or HCC Multi-drop: Up to 15 gauges connected to PC or HCC	
Fieldbus	RS 485 (SMART):	Up to 255 per junction box with PC link
	Profibus PA:	GSD & EDD files supplied with gauge

Weight

Non-Ex/FM Housing	8 kg / 18 lb with DN50 PN10/16 flange
Ex/FM Housing	9 kg / 20.25 lb with DN50 PN10/16 flange
Rod Ø10mm	1.24 kg/m / 0.83 lb/ft
Cable Ø4mm	0.12 kg/m / 0.08 lb/ft
Cable Ø6mm	0.28 kg/m / 0.19 lb/ft
Cable Ø8mm	0.41 kg/m / 0.28 lb/ft
Coaxial Ø28mm	1.10 kg/m / 0.74 lb/ft







Standards

E.U. EMC (Electromagnetic Compatibility) directives	-Conforms to Directive 89/336/CEE in conjunction with: EN 50081-1&2 (Emissions) EN50082-1&2 (Immunity)
Other protection directives for EU countries	-EM emissions shielding : Class A* (*Class B shielding available on demand) - Conforms to Directive 73/23/EEC in conjunction with: EN 61010-1

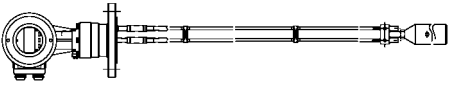
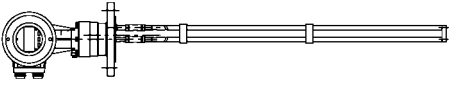
4.2 VF04 Equipment Architecture

		Liquid / Liquid Gas applications							
		Granulate / solid applications				Powder applications			
Probe Type Code)	Description	Twin cable Ø16mm (B)	Twin rod Ø10mm (A)	Coaxial Ø28 (D)	Twin cable Ø4mm (L)	Single cable Ø4mm (H)	Reverse Ø10mm (G)	Single rod Ø10mm (F)	Single cable Ø8mm (K)
		Two flexible 316 SS cables with spacers interspersed along its length, with short-circuit and counterweight.	Two rigid rods with spacers interspersed along its length, with short-circuit.	Single inner conductor with protective tube.	Two flexible 316 SS cables with spacers interspersed along its length, with counterweight.	Single 316 stainless steel flexible cable with counterweight.	One inner conductor in protective tube and one reference rod connected by a short circuit.	Single rigid rod	Single 316 stainless steel flexible cable with long counterweight.
Level									
Interface		***	***	***	***				
Level and Interface		(Liquid only)	(Liquid only)						
Range, max.		$\leq 30 \mu / 98.5\phi r^*$	$\leq 3 \mu / 10\phi r^*$	$\leq 6 \mu / 20\phi$	$\leq 60 \mu / 197\phi r$	$\leq 45 \mu / 148\phi r$	$\leq 6 \mu / 20\phi r^*$	$\leq 3 \mu / 10\phi r^*$	$\leq 30 \mu / 98.5\phi r^*$
Min er direct mode		1.8	1.8	1.4	1.8	2.1	-	2.1	2.1
Minimum process connection		DN50 PN10/16 2"ANSI 150lbs 2 1/2 " G / 2 1/2 " NPT**	DN50 PN10/16 2"ANSI 150lbs 2 1/2 " G / 2 1/2 " NPT**	DN40 PN25/40 1 1/2"ANSI 150lbs 1" G / 1"NPT	DN50 PN10/16 2"ANSI 150lbs 2 1/2 " G / 2 1/2 " NPT**	DN40 PN25/40 1 1/2" ANSI 150lbs 1 1/2 " G / 1 1/2 " NPT	DN50 PN10/16 2"ANSI 150lbs 2 1/2 " G / 2 1/2 "NPT**	DN40 PN25/40 1 1/2" ANSI 150lbs 1 1/2" G / 1 1/2"NPT	DN40 PN25/40 1 1/2" ANSI 150lbs 1 1/2" G / 1 1/2" NPT
Probe material		SS316/316L	SS316L HC276 HB2/HB3** Tantalum**	SS316L HC276	SS316/316L	SS316/316L HC22 SS316 + FEP coating	SS316L HC276	SS316L HC276 HB2/ HB3** PVDF-coated PVC-coated	SS316/316L

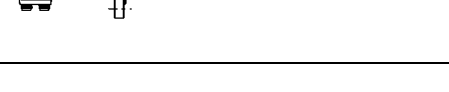
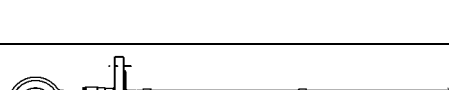
ϵ_r = dielectric constant of measured product Liquid / Liquid Gas only * Higher on request ** On request *** No air gap

		Liquid / Liquid Gas applications						Powder applications	
		Granulate / Solid applications							
Probe (Type code)	Twin cable Ø6mm (B)	Twin rod Ø10mm (A)	Coaxial Ø28 (D)	Twin cable Ø4mm (L)	Single cable Ø4mm (H)	Reverse Ø10mm (G)	Single rod Ø10mm (F)	Single cable Ø8mm (K)	
Spacer material	FEP molded on cable	ETFE (Tefzel) if L > 1.5m	PTFE if L > 1.5m	FEP molded onto cable	No spacer	ETFE (Tefzel) if L > 0.7m	No spacer	No spacer	
Counter-weight	D45x245 (316L) D90x100 (316L) Turnbuckle (316L) Without**	None	None	D45x60(316L) Turnbuckle (316L)	D25x100 (316L) D25x100 (HC22) D25x10 (HC276) Chuck(316L) Turnbuckle (316L)	None	None	D45x245(316L) D12x1500(316L) Turnbuckle (316L) Without**	
Free area (diameter)	200 mm / 8"	200 mm / 8"	0 mm / 0"	200 mm / 8"	600 mm / 24"	200 mm / 8"	600 mm / 24"	600 mm / 24"	
Gauge illustration									

4.3 Probe measurement limits

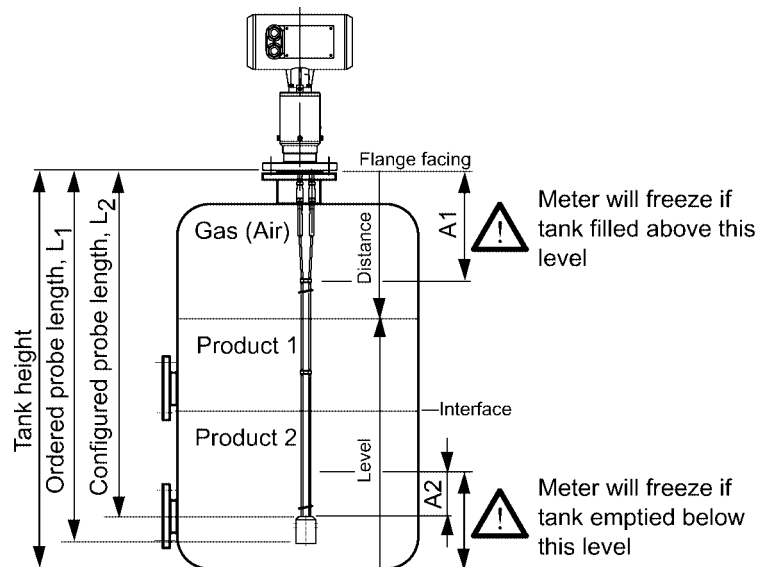

Probe measurement limits				
Probe type	Top dead zone, A1 $\epsilon_r = 80^*$	Bottom dead zone, A2 $\epsilon_r = 80^*$	Top dead zone, A1 $\epsilon_r = 2.4^*$	Bottom dead zone, A2 $\epsilon_r = 2.4^*$
Twin rod (A)	250 mm / 9.8"	20 mm / 0.8"	330 mm / 13"	100 mm / 3.9"
Twin cable Ø6 mm (B)	250 mm / 9.8"	20 mm / 0.8"	330 mm / 13"	100 mm / 3.9"
Twin cable Ø4 mm (L)	250 mm / 9.8"	20 mm / 0.8"	330 mm / 13"	100 mm / 3.9"
Coaxial (D)	0 mm / 0" (**)	10 mm / 0.4"	0 mm / 0" (***)	100 mm / 3.9"
Single rod (F)	400 mm / 15¾"	20 mm / 0.8"	500 mm / 19.7"	100 mm / 3.9"
Reverse(G)	50 mm / 2"	250 mm / 9.8"	N/a	N/a
Single cable Ø4 mm (H)	400 mm / 15¾"	20 mm / 0.8"	500 mm / 19.7"	100 mm / 3.9"
Single cable Ø8 mm (K)	400 mm / 15¾"	20 mm / 0.8"	500 mm / 19.7"	100 mm / 3.9"

*The dielectric constant, ϵ_r , of water is 80. The dielectric constant, ϵ_r , of oil is 2.4.

** 20 mm / 0.8" for Ex version.

*** 50mm / 2" for Ex version.

4.4 Gauge dimensions

The drawing below illustrates the complete set of standard gauge configurations and overall dimensions.

Housing

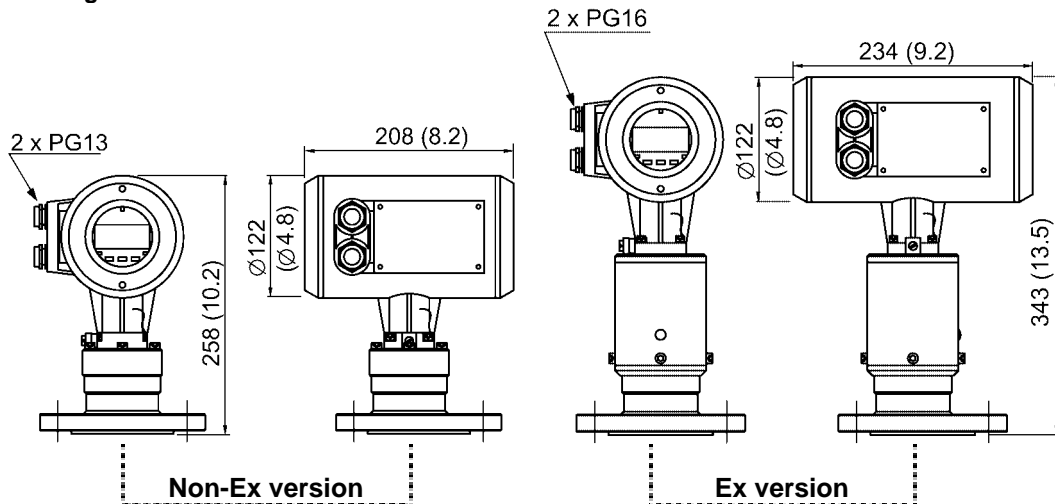

Probe

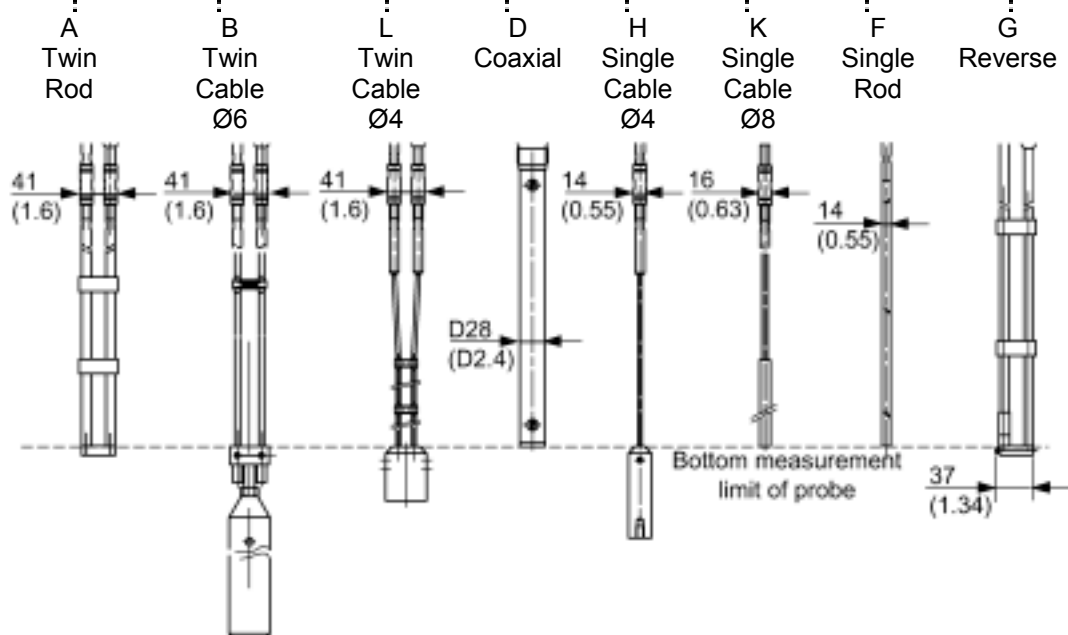

Standard counterweight

N/a	Ø45x245 (Ø1 ³ / ₄ x9 ¹ / ₂)	Ø45x60 (Ø1 ³ / ₄ x2 ¹ / ₂)	N/a	Ø25x100 (Ø1x4)	Ø12x1500 (Ø1 ¹ / ₂ x59)	N/a	N/a
-----	---	--	-----	-------------------	--	-----	-----

Dimensions in mm (inches)

If you need to return a device for testing or repair to HYCONTROL

Your instrument has been carefully manufactured and tested. If installed and operated in accordance with these operating instructions, it will rarely present any problems. Should you nevertheless need to return an instrument for servicing or repair, please pay strict attention to the following points:

- Due to statutory regulations on environmental protection and safeguarding the health and safety of our personnel, HYCONTROL may only handle, test and repair returned instruments that have been in contact with liquids if it is possible to do so without risk to personnel and environment.
- This means that HYCONTROL can only service your instrument if accompanied by the following certificate confirming that the instrument is safe to handle. If the instrument has been operated with toxic, caustic, flammable or water-endangering liquids, you are kindly requested :
- to check and ensure, if necessary by rinsing or neutralising, that all cavities in the instrument are free from such dangerous substances. (Directions on how you can find out whether the primary head has to be opened and flushed out or neutralised are obtainable from HYCONTROL on request.)
- to attach a certificate to the instrument confirming that the instrument is safe to handle and stating the liquid used.

We cannot service your instrument unless accompanied by such a certificate.

Specimen certificate

Company: _____ Address: _____

Department: _____ Name: _____

Tel. No.: _____ Fax No.: _____

The enclosed instrument _____

Type: _____

HYCONTROL Order No. _____
or Series No. _____

has been operated with the following process
liquid _____

Because this process liquid is

- water-hazardous
- toxic
- caustic
- flammable

we have

- checked that all cavities in the instrument are free from such substances
- flushed out and neutralised all cavities in the instrument

We confirm that there is no risk to humans or environment through any residual liquid contained in the instrument.

Date: _____ Signature: _____

Company stamp: