



# MICROFLEX

## INSTRUCTION MANUAL

ISSUE 2. MAY 2001.

### **HYCONTROL LTD**

Larchwood House, Orchard Street, Redditch, Worcestershire,  
B98 7DP, United Kingdom.

Tel: + 44 (0)1527 406800 Fax: + 44 (0)1527 406810

E-mail: [sales@hycontrol.com](mailto:sales@hycontrol.com) Website: [www.hycontrol.com](http://www.hycontrol.com)

# **MICROFLEX PROGRAMMABLE LEVEL CONTROLLER**

## **INSTALLATION INSTRUCTIONS**

### **DESCRIPTION**

Microflex is a programmable measurement instrument for level monitoring in vessels up to 6 metres deep; it is 2-wire loop-powered by battery or normal dc power.

Microflex is capable of measuring level or distance and will display in metres, feet or percentage of programmed span.

Microflex consists of two elements, a wall mounted transceiver and a transducer which can be located up to 100 metres apart; the transducer must be mounted directly above the surface to be monitored .

Ultrasonic pulses are transmitted by the transducer to the surface being monitored and are reflected back to the transducer. The time period between transmission and reception of the sound pulses is directly proportional to the distance between the transducer and the liquid.

A red led on the front panel illuminates when the instrument is processing a good signal.

## INSTALLATION

### TRANSCEIVER MOUNTING

Undo the 4 screws on the front panel and remove the lid to expose the 4 mounting holes molded into the enclosure.

Mount the unit on a flat surface and secure it via the 4 mounting holes. **DO NOT** use excessive force when tightening the fixings and avoid any distortion of the enclosure.

Ensure that the mounting surface is not subject to vibration and is not in close proximity to high voltage cables, contactors or drive controls. The unit should not be mounted in a confined space where temperatures may exceed the normal working temperature. If the unit is mounted outside it must be protected from direct sunlight or severe weather conditions.

Fit suitable cable glands / blanking plugs to achieve the necessary IP rating.

**Figure 1:**

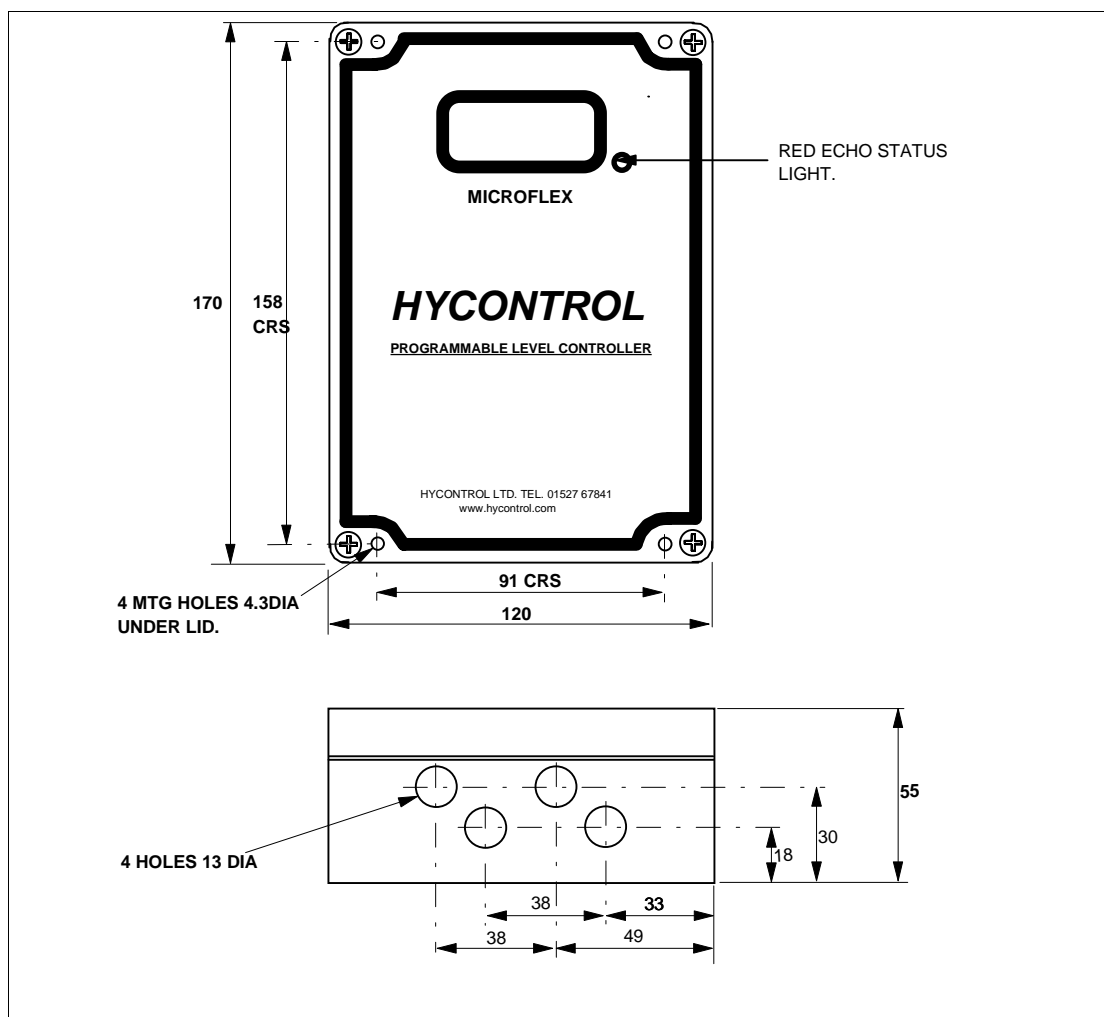

## ELECTRICAL CONNECTIONS

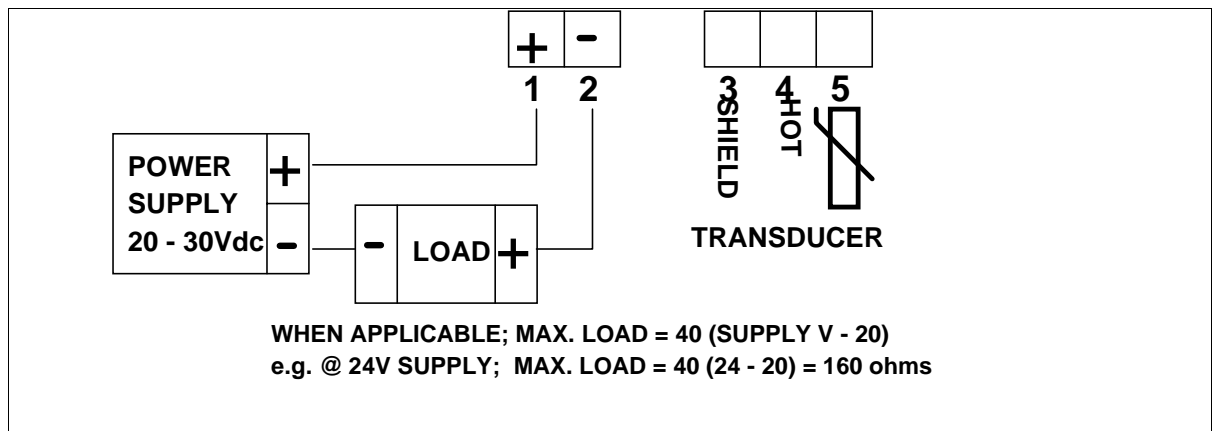

Microflex has two part screw terminals; the top part can be removed for ease of connection.

It can be powered from a normal DC supply or batteries.

### DC Supply

20 - 30VDC

(0.75W fuse capacity)

Connect :- Positive +ve to terminal 1  
Negative -ve to terminal 2

### Transducer

Temperature compensated transducer RZT15

Connect: Shield to terminal 3  
Blue to terminal 4  
Black to terminal 5



**Figure 4:**

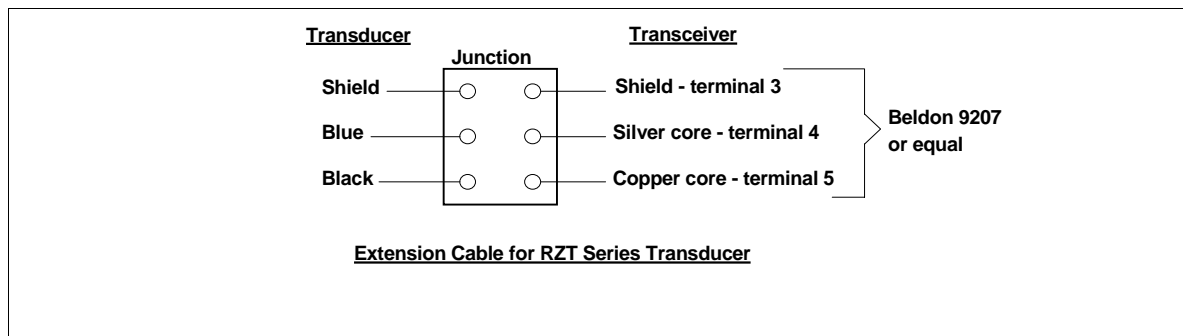

### ALTERNATIVE MOUNTING ARRANGEMENTS FOR TRANSDUCERS

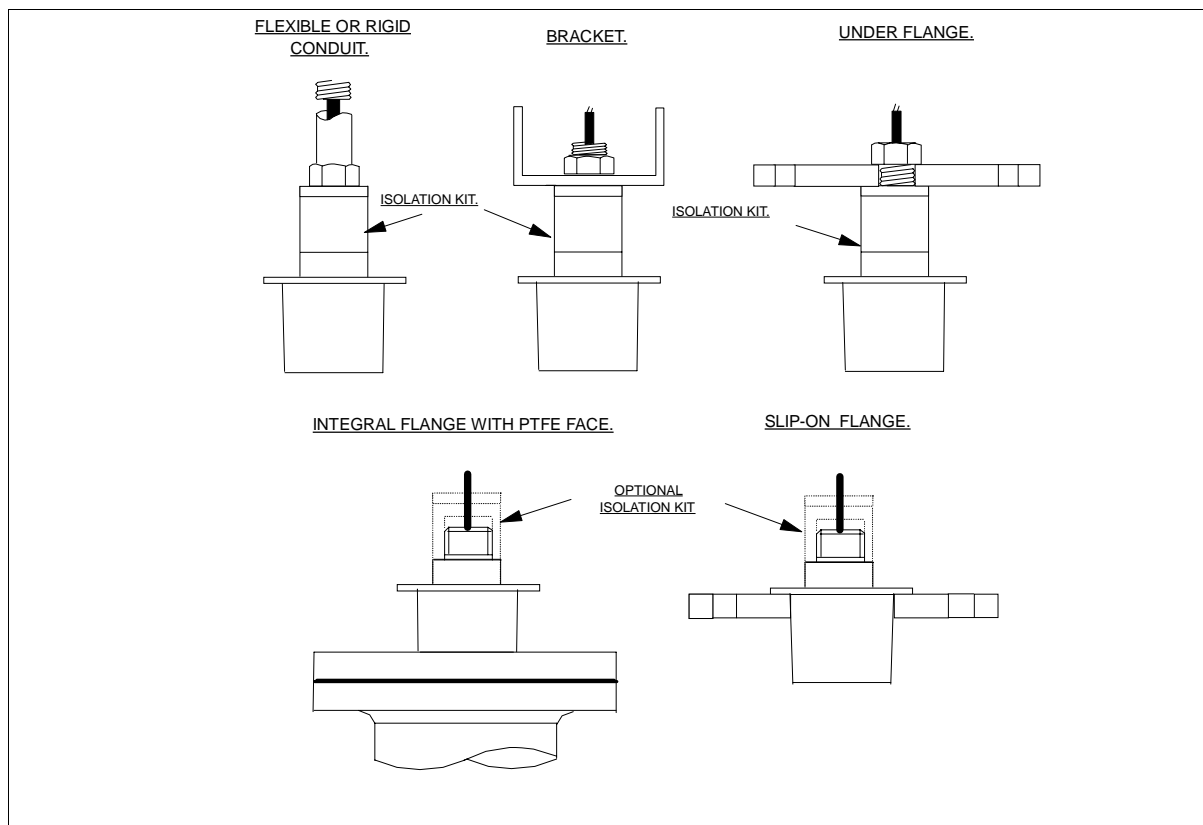

DO NOT mount the transducer in direct sunlight

DO NOT over tighten the bolts on flange construction transducers

USE ONLY at atmospheric pressure.

CENELEC approved transducers must be mounted and wired in accordance with the appropriate national standards concerning installation within hazardous environments.

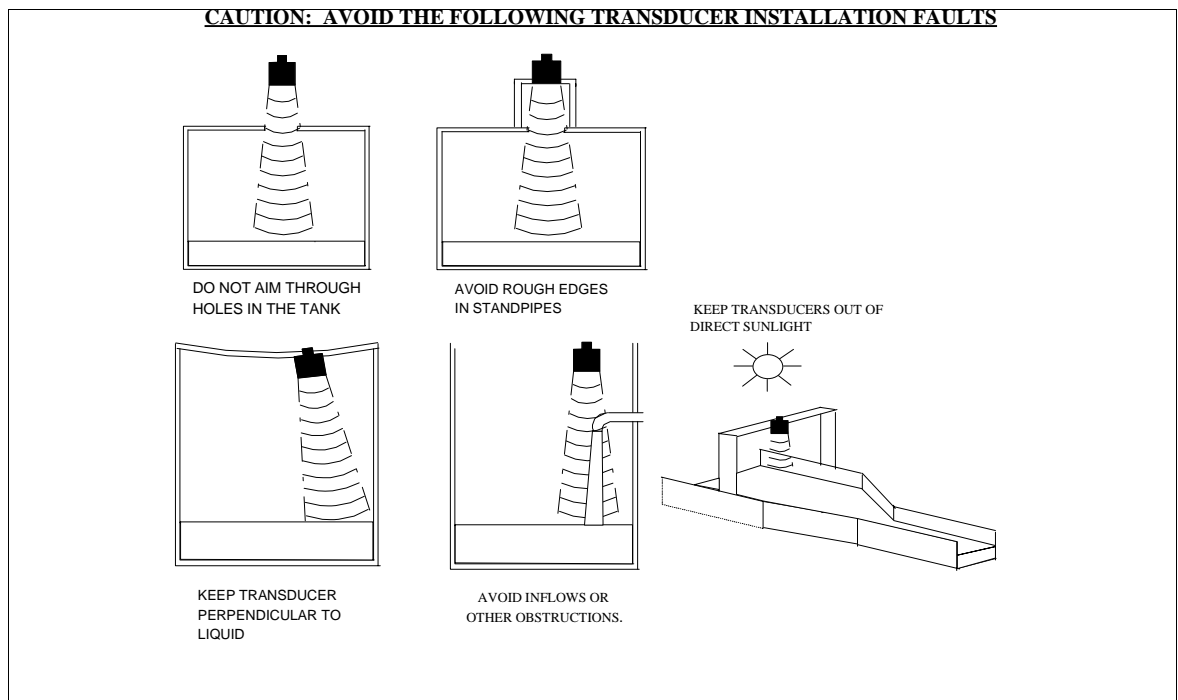

## STANDPIPE INSTALLATIONS

Note the following basic rules when using a standpipe:-

**BLANKING:** Parameter 5 should always be set at least 150mm longer than the length of the standpipe.

**STANDPIPE DIMENSIONS:** Should be in accordance with the following table

Flange size and minimum bore of Standpipe		Maximum length of Standpipe
3"	( 80mm)	300mm
4"	(100mm)	300mm
6"	(150mm)	400mm
8"	(200mm)	600mm

e.g. Using a 4" flanged transducer would require the standpipe length to be no more than 300mm and Pr.5 set at 450mm minimum. Note max. integral flange is 4" (100mm)

**THE INSIDE OF THE PIPE AND JOINT WITH VESSEL TOP MUST BE CLEAN AND FREE OF ANY OBSTRUCTIONS, SEAMS OR WELDS**

**MICROFLEX  
PROGRAMMING INSTRUCTIONS AND PARAMETER LISTING**

Microflex is programmed by entering values for each of the following Parameters.

**PARAMETER DEFINITIONS**

Pr. No	Description	Acceptable Values	Default Value
<u>Pr. 1</u>	<u>Application</u> <b>NOTE:</b> - Changing entry will default Pr.3 - Pr.7. (Will not default "feet" setting to "metres")	1 - Level 2 - Distance	1
<u>Pr. 2</u>	<u>Display Units</u> <b>NOTE:</b> - Changing entry will default Pr.3 - Pr.7.	1 - Metre 2 - % Metre 3 - Feet 4 - % Feet	1
<u>Pr. 3</u>	<u>Empty Distance</u>  The distance from the face of the transducer to the furthest point away, usually the bottom of the sump or channel.	0.30 to 6.000 Metre 1.0 to 20.0 Feet	
<u>Pr. 4</u>	<u>Span</u>  The distance between the furthest and the nearest points over which measurement is required.	0.030 to 6.000 Metre 0.1 to 20.0 Feet	
<u>Pr. 5</u>	<u>Blanking Distance</u>  The distance in front of the transducer within which the liquid should not enter, and within which no return echoes will be processed.	0.300 to 6.000 Metre 1.0 to 20.0 Feet	
<u>Pr. 6</u>	<u>Rate of Change</u>  This value should be as small as possible, but greater than the maximum fill or empty rate.	0.100 to 9.999 Mtr/Min 1.0 to 30.0 Feet/ Min	
<u>Pr. 7</u>	<u>Test Output</u> Toggles output 4 / 20mA to calibrate external instruments (Refer to Instruction 7)	Viewable only	4 / 20

If the instrument loses signal for any reason the echo light will go off after 15 secs. The instrument will continue to display the last valid level or distance for a period of 2.3 mins whilst the search for a valid echo continues. If no echo is found after this time, the instrument will display LOSt and output will go to 22mA

**Note:-** Calibration is in measurement units selected in Pr.2 even when percent is selected for the display.

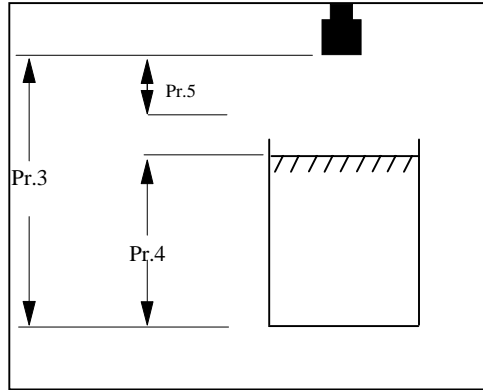

## PROGRAMMING INSTRUCTIONS FOR MICROFLEX

### Programming

Parameters are displayed and programmed using the 5 keys shown below which are accessed by removing the transceiver's front cover.

### Key Definitions

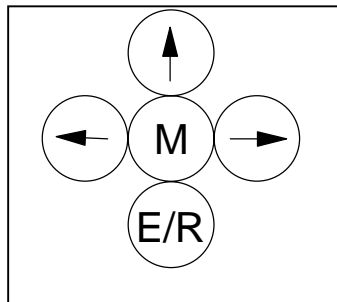

M = Mode key - to go from "RUN" to "Prog" Mode  
 - or from Parameter Number to Parameter Value

E/R = ENTER/RUN - to enter a value change  
 - or to return from "Prog" to "RUN" Mode.

↑ = Increase a Parameter No. or Value

← = Moves cursor Left

→ = Moves cursor right

**1) To Enter Programme**

Press M - Display will show "Prog"

Press  $\uparrow$  Immediately - Display will show Pr.1 and its value alternately

**2) To Select a Parameter No. or to view the Values in each Pr. No.**

Continue to press  $\uparrow$  - Display will progress from Pr.1 to Pr.7 with each press. Pause after each press to read the Pr. value.

**3) To Change the value of a selected Parameter**

Press M again - Display will now show only the value of the selected Pr. number and a cursor will flash in place of the first digit.

Press  $\uparrow$  - To increase value of flashing digit between 0 and 9. It will then roll over to its minimum and start again.

Press  $\rightarrow$  - To move the cursor right and select the next digit to be changed, then Press  $\uparrow$  to change its value as above.

Press  $\leftarrow$  - To move the cursor to the left and then Press  $\uparrow$  to change its value as above.

Press E/R To enter the new value. The display will then show the Pr. Number and the new value alternately.

**4) To select another Pr. - and change its value**

Press  $\uparrow$  Proceed as 2 and 3 above.

**5) To complete Programming and return to RUN mode**

Press E/R The display will show "RUN" and then the measured value in the selected units.

**6) To Reset all Parameters to Factory Default**

Press M Displays "Prog".

Press  $\uparrow$  To display Pr.1

Press both  $\leftarrow$  and  $\rightarrow$  simultaneously -To display "PrES" and then Pr.1

## 7) To Calibrate External Instruments

Press M      Displays "Prog"

Press ↑      To display Pr.1, then advance to Pr.7

Press M      To display 4.00 or 20.00mA

Press ↑      To toggle between 4 & 20mA

Press E/R twice      To return to "Run"

## 8) Alternative Key Functions

The 4 peripheral keys have secondary functions which can be viewed without interrupting the instrument's operation.

In the normal "RUN" mode:-

Press ↑      Display will show "dEgC" and the operating temperature if using a temperature compensated transducer or 20C with standard transducer

Press →      Display will show "GAIN" and then a number from 0.1 to 100 which represents strength of echo. Low numbers mean strong echo.

Press E/R      Display will show "dISt" and measured distance from transducer face regardless of whether programme is in distance, level or percent.

Press ←      Display will show "AnA" and then the mA output.

## MICROFLEX SPECIFICATION

<b>Measurement</b>	:	Level or Distance or Percent									
<b>Range</b>	:	6 m maximum on liquids									
<b>Blanking</b>	:	0.5 m - adjustable									
<b>Transducer</b>	:	RZT15 with integral T Comp and PTFE flanged face options									
<b>Accuracy of change in level</b>	:	1% of measured distance at 20°C									
<b>Resolution of analogue output</b>	:	2 mm or 0.1% of empty distance whichever is the greater									
<b>Power Supply</b>	:	20-30 VDC 0.66 Watt max									
<b>Analogue Output</b>	:	4-20 mA (12 bit) Fixed to span									
		<table border="0" style="margin-left: auto; margin-right: auto;"> <tr> <td></td> <td style="text-align: center;">LEVEL</td> <td style="text-align: center;">DISTANCE</td> </tr> <tr> <td>Closest to Transducer</td> <td style="text-align: center;">20 mA</td> <td style="text-align: center;">4 mA</td> </tr> <tr> <td>Furthest from Transducer</td> <td style="text-align: center;">4mA</td> <td style="text-align: center;">20mA</td> </tr> </table>		LEVEL	DISTANCE	Closest to Transducer	20 mA	4 mA	Furthest from Transducer	4mA	20mA
	LEVEL	DISTANCE									
Closest to Transducer	20 mA	4 mA									
Furthest from Transducer	4mA	20mA									
<b>Maximum Load</b>	:	400 ohms @ 30 Vdc 160 ohms @ 24 Vdc									
<b>Ambient Temperature</b>	:	-40 to +70 °C									
<b>Indication</b>	:	4 digit 12 mm LCD 1 led for echo status									
<b>Key Functions</b>	:	5 Push Buttons M - Prog/alternate display ↑ - Increase Pr. or digit ← - Move left → - Move right									
<b>Approvals</b>	:	E/R - Change its value as above. CE Compliant to EN55022 EN61000-6-2 RZ Series transducers EExmIIT6 for Zones 1 & 2 Temperature Range -20C to + 60C									