

LIQUIFLEX

PROGRAMMABLE LEVEL CONTROLLER

INSTRUCTION MANUAL



HYCONTROL LIMITED

Larchwood House, Orchard Street, Redditch,
Worcestershire, B98 7DP.

Tel: 01527 406800

Fax: 01527 406810

Web: www.hycontrol.com

Email: sales@hycontrol.com

LIQUIFLEX USER MANUAL - INDEX

	<u>Page</u>	<u>Drawings</u>
Introduction	1	
Section 1		
Installation	2	
Transceiver Mounting	2	Fig. 1
Transceiver Wiring	3	Fig. 2
Transducer Mounting	4	Fig. 3
Transducer Alternative Mounting	5	Fig. 4
Transducer Mounting Faults	6	Fig. 5
Transducer Stand Pipe	6	
Transducer Cable Extensions	7	Figs. 6 & 7
Temperature Sensor	8	Fig. 8
Section 2		
Easy Start for Liquiflex	9	
Quick Start Guide	9	
Principle of Programming	9	
Keypad Definitions	10	
To View Parameters	11	
Programming Example	12	
Programme Checking & Correction	13	
Section 3		
Programming	14	
Principle of Programming	14	
Keypad Definitions	14	
Display Descriptions	14	
Security Code	15	
Application Programming	16	
Entering a New Programme	17	
Section 4		
Parameter Index	18	
Parameter Definitions	19 to 34	
Section 5		
Examples	35	
1. Level Measurement Mode	35	
2. Contents, Volume Conversion	36	
3. Pump Control	37	
4. Differential	38	
5. Open Channel Flow	39	
6. Open Channel Flow with Penstock	40	
Section 6		
Commissioning Fault Finding	41 to 45	
APPENDIX 1		
LINEARISATION OF SPECIAL VESSELS OR FLUMES	46 to 50	
APPENDIX 2		
SPECIFICATION	51	
APPENDIX 3		
ATEX INSTALLATIONS	52 to 53	
APPENDIX 4		
BS3680 FLOW	54	
APPENDIX 5		
PARAMETER SETTINGS	55	
APPENDIX 6		
PARSHALL FLUMES	56	

LIQUIFLEX PROGRAMMABLE LEVEL CONTROLLER

USER MANUAL

INTRODUCTION

Liquiflex

Liquiflex is a programmable multi-purpose liquid level measurement and flow control instrument. It consists of two elements, a wall mounted transceiver which has a display and an integral keypad for programming, and a transducer which must be mounted directly above the surface to be monitored.

Ultrasonic pulses are transmitted by the transducer to the surface of the liquid to be monitored and are reflected back to the transducer. The time period between transmission and reception of the sound pulses is directly proportional to the distance between the transducer and the liquid.

Since speed of sound through air is affected by changes in temperature, a separate or integrated temperature sensor may be fitted to improve accuracy.

Liquiflex is capable of the following functions:-

- a) Level Measurement (height above datum)
- b) Distance Measurement (distance from a datum)
- c) Differential Level Measurement
- d) Open Channel Flow Measurement (O.C.M.)
- e) Pump Control
- f) Volume Measurement

WARNING

**DO NOT OPEN THE TRANSCEIVER DOOR WHEN THE
POWER IS ON TO
THE SUPPLY OR RELAY TERMINALS.**

b Transducer Electrical Connections - Figure 2

The wall mount instrument has two-part screw terminals. It can be powered from either an AC or DC supply.

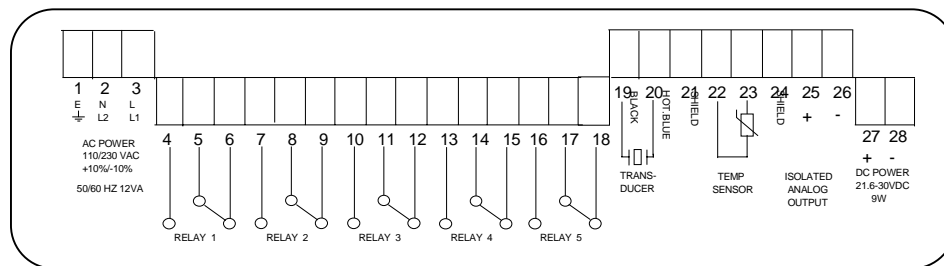
Figure 2:

AC power supply - connected:-

Earth	to terminal 1
Neutral	to terminal 2
Live	to terminal 3

The instrument will automatically accept either 110V or 230V AC $\pm 10\%$, 50Hz or 60Hz, 12VA. A time lag fuse T160mA is fitted.

DC power supply - connected :-

Positive +ve	to terminal 27
Negative -ve	to terminal 28

The instrument will accept 24V DC + 25%, - 10%. 9W.
A time lag fuse T315mA is fitted.

5 SPDT Relays - rated 8A/250V AC/30V DC resistive, with gold contacts for lower power switching, are connected to terminals 4 to 18, for activating external alarms, contactors, pumps etc..

Transducer RZV15 - is connected:-

Black	to terminal 19
Blue	to terminal 20
Screen	to terminal 21

Temperature compensated transducer RZT15 - is connected:-

(Screen	to terminal 19	
Must enable Pr.37	(Blue	to terminal 20
	(Black	to terminal 22

Isolated Analogue - is connected :-

Screen	to terminal 24
Positive +ve	to terminal 25
Negative -ve	to terminal 26.

Separate Temperature Compensation - when compensation is provided by a separate temperature sensor, the sensor should be connected with a shielded twisted pair and connected:-

(Screen	to terminal 21	
Must enable Pr.37	(Core*	to terminal 22
	(Core*	to terminal 23

* The polarity of the cores is unimportant, but it is important that the screen is connected only at the instrument end and not at the temperature sensor end.

c Transducer Mounting

The transducer can be supplied as 'standard' or mounted in a Teflon faced flange for applications requiring chemical compatibility. Figure 3 shows the dimensions:

Figure 3:

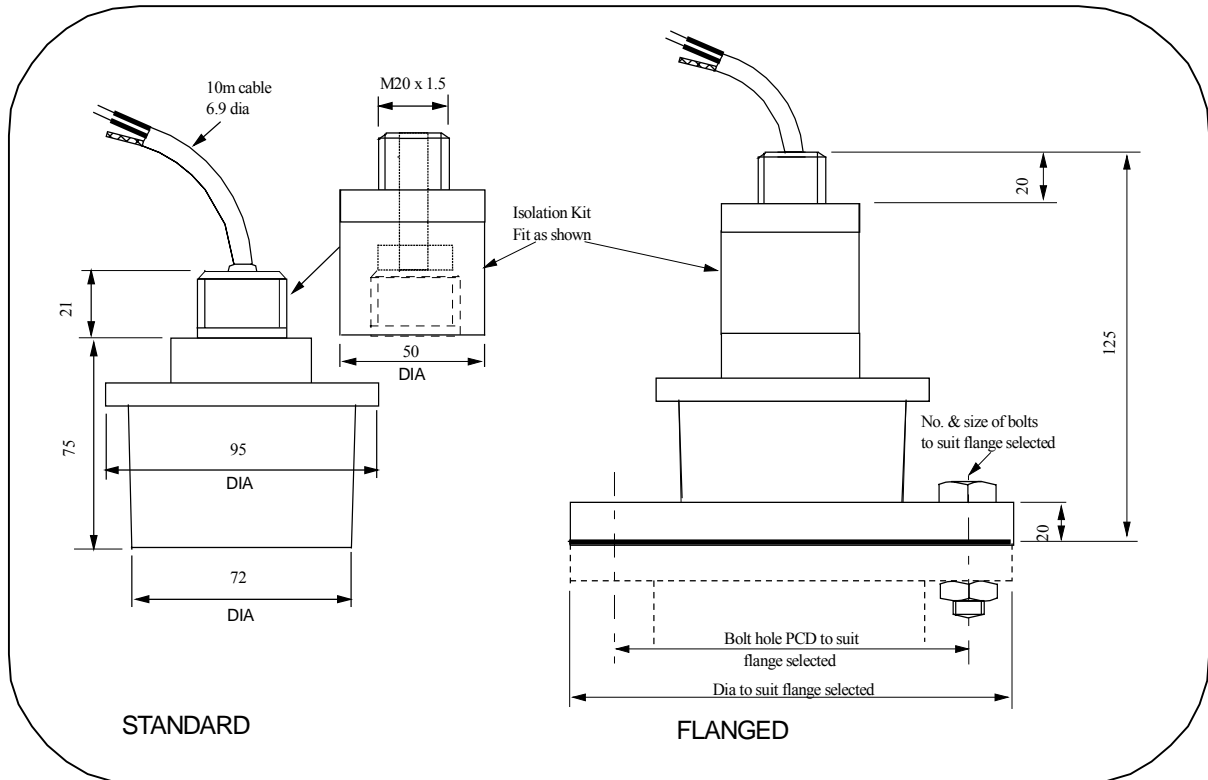

An isolation kit is provided with each transducer to minimise any ringing transmitted through the mounting structure.

The transducer must be mounted perpendicular to the monitored surface and, ideally, at least 0.5 metres above it.

The transducer has a 10° inclusive conical beam angle at 3dB and must be mounted with a clear unobstructed sight of the liquid to be measured over the complete measurement range.

The transducer is provided with integral cable which can be extended up to 300 metres using a suitable junction box and RG62AU cable. The temperature compensated transducer requires an additional single core screen extension, or twin-ax cable.

The extended cable should then be terminated directly into the instrument.

Transducer cables and temperature compensation cables can be run together but should be separated from power cables by at least 150mm and preferably installed in their own earthed steel conduit.

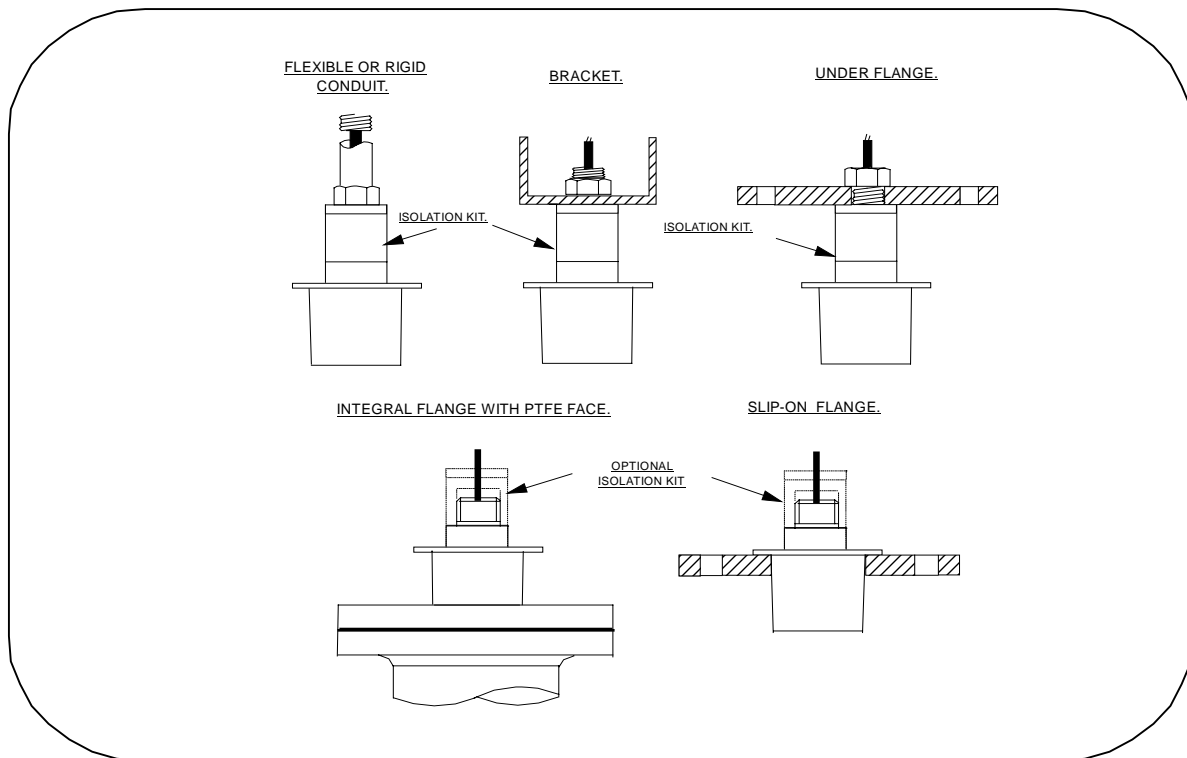
Figure 4: Alternative mounting arrangements for transducers

Do not mount transducers incorporating temperature compensation in direct sunlight.

Do not over-tighten the bolts on flange construction transducers.

Flange transducers are not pressure rated and are suitable only for atmospheric pressure.

CENELEC approved transducers must be mounted and wired in accordance with the appropriate National Standards concerning installation in hazardous environments.

For differential applications mount both transducers at the same height above the zero datum point.

For open channel flow applications the transducer must be mounted upstream of the flume or weir as detailed in BS3680 (usually 3 or 4 times maximum head).

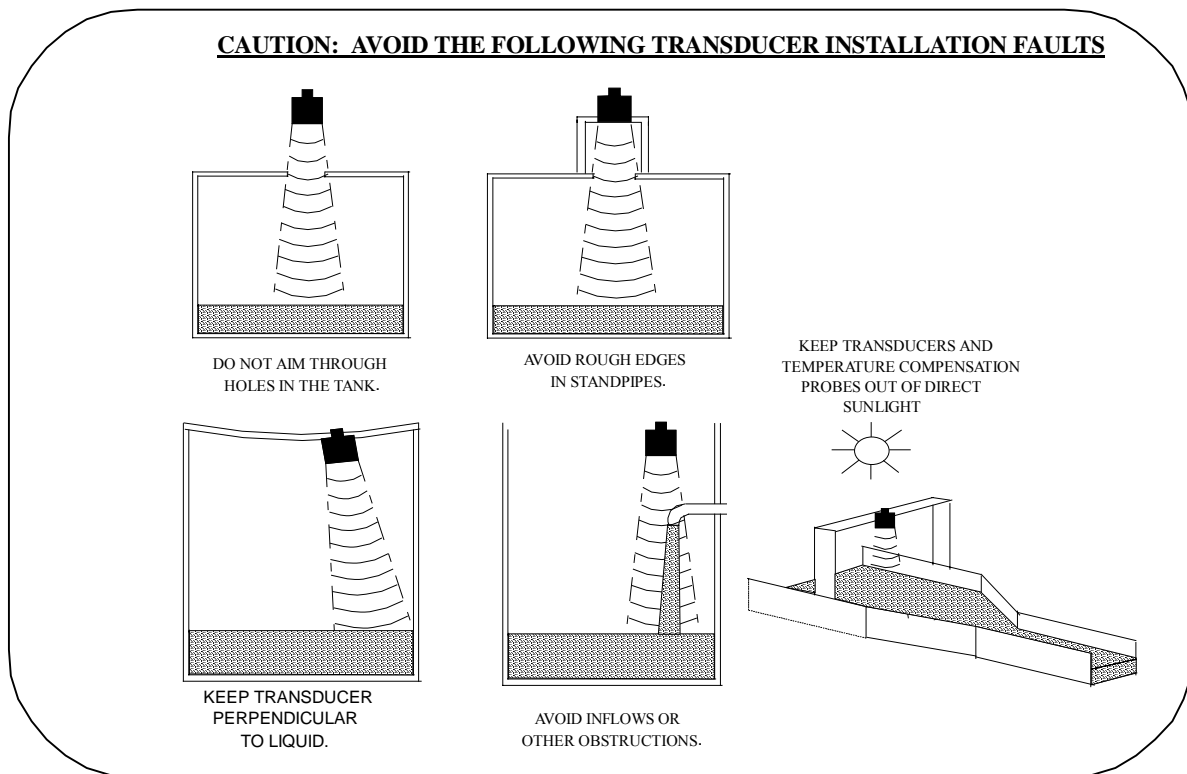
Figure 5:

Standpipe Installations

In many applications access to a vessel must be made via a standpipe. However, it is necessary to observe some basic rules when fitting transducers into standpipes.

BLANKING: Parameter 5 should always be set at least 150mm longer than the length of the standpipe.

STANDPIPE DIMENSIONS: should be in accordance with the following table

<u>Flange size and minimum bore of Standpipe</u>		<u>Maximum length of Standpipe</u>
3"	(75mm)	300mm
4"	(100mm)	300mm
6"	(150mm)	400mm
8"	(200mm)	600mm
12"	(300mm)	600mm

e.g. Using a 4" flanged transducer would require the standpipe length to be no more than 300mm and Pr.5 set at 450mm minimum.

The inside of the pipe and joint with vessel top must be clean and free of any obstructions, seams or welds.

Transducer Cable Extensions

Transducer cables may be extended using junction boxes as shown in Figure 6:

Figure 6:

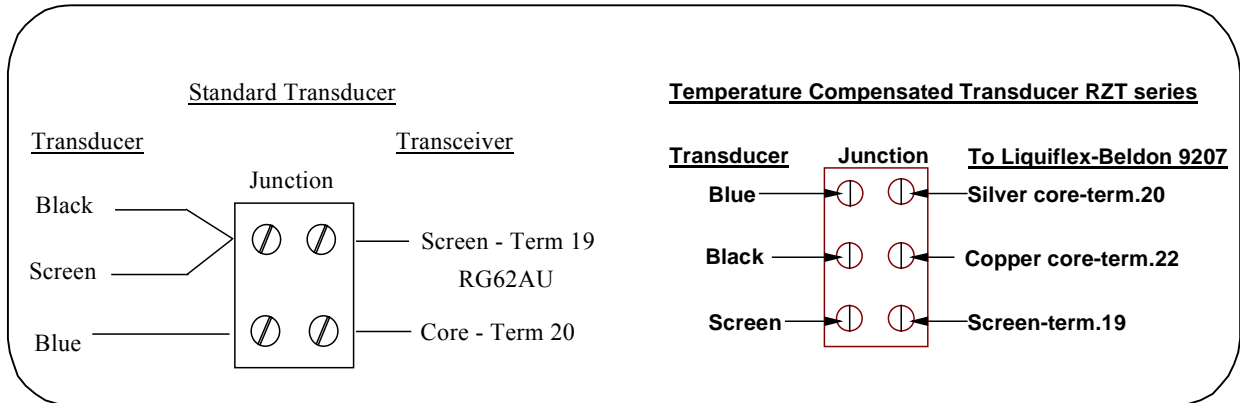
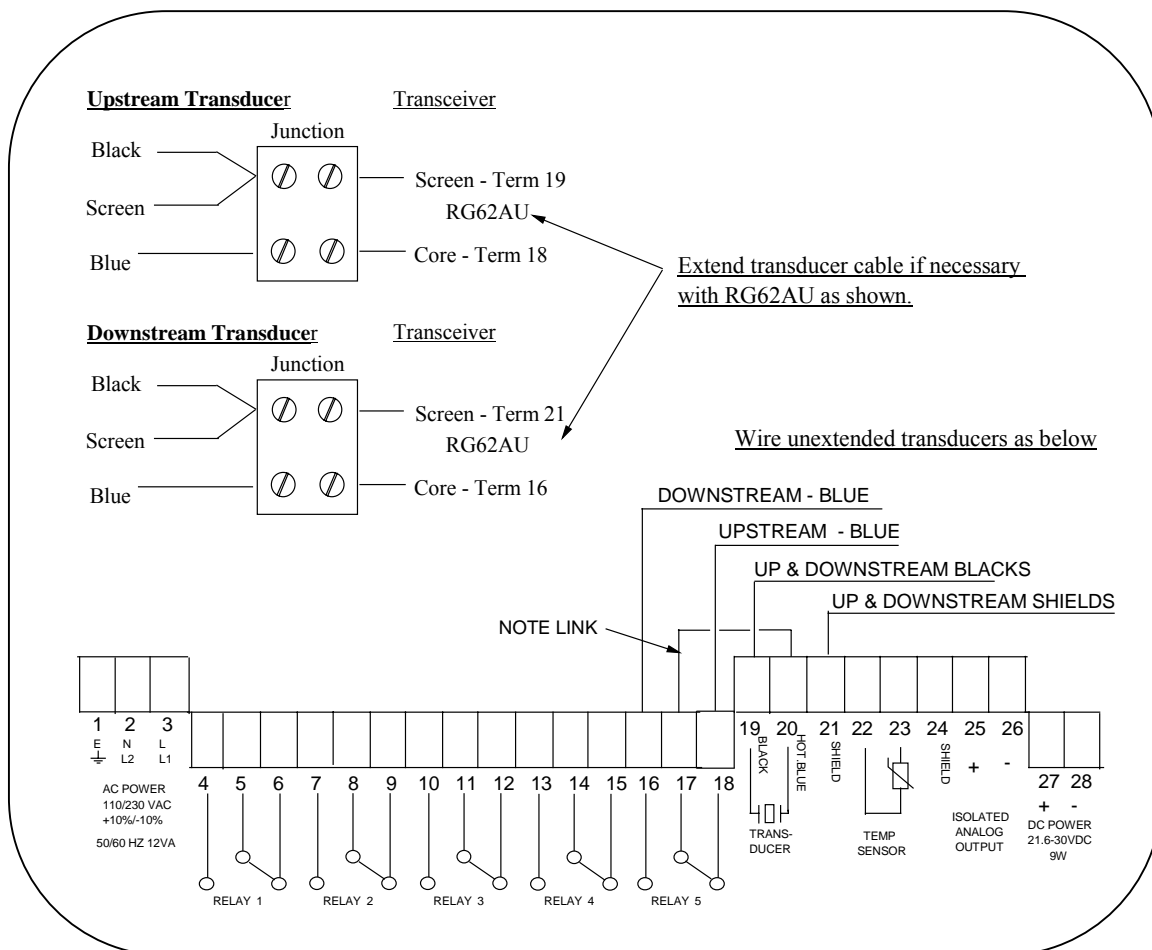

Figure 7: Transducer Wiring for Differential Mode



Temperature Sensor

If a separate temperature sensor is to be used it must be mounted where it will monitor temperature changes of the air between the transducer and the liquid. This is usually adjacent to the transducer, but should not be in direct sunlight and should be protected from wind chill.

Figure 8:

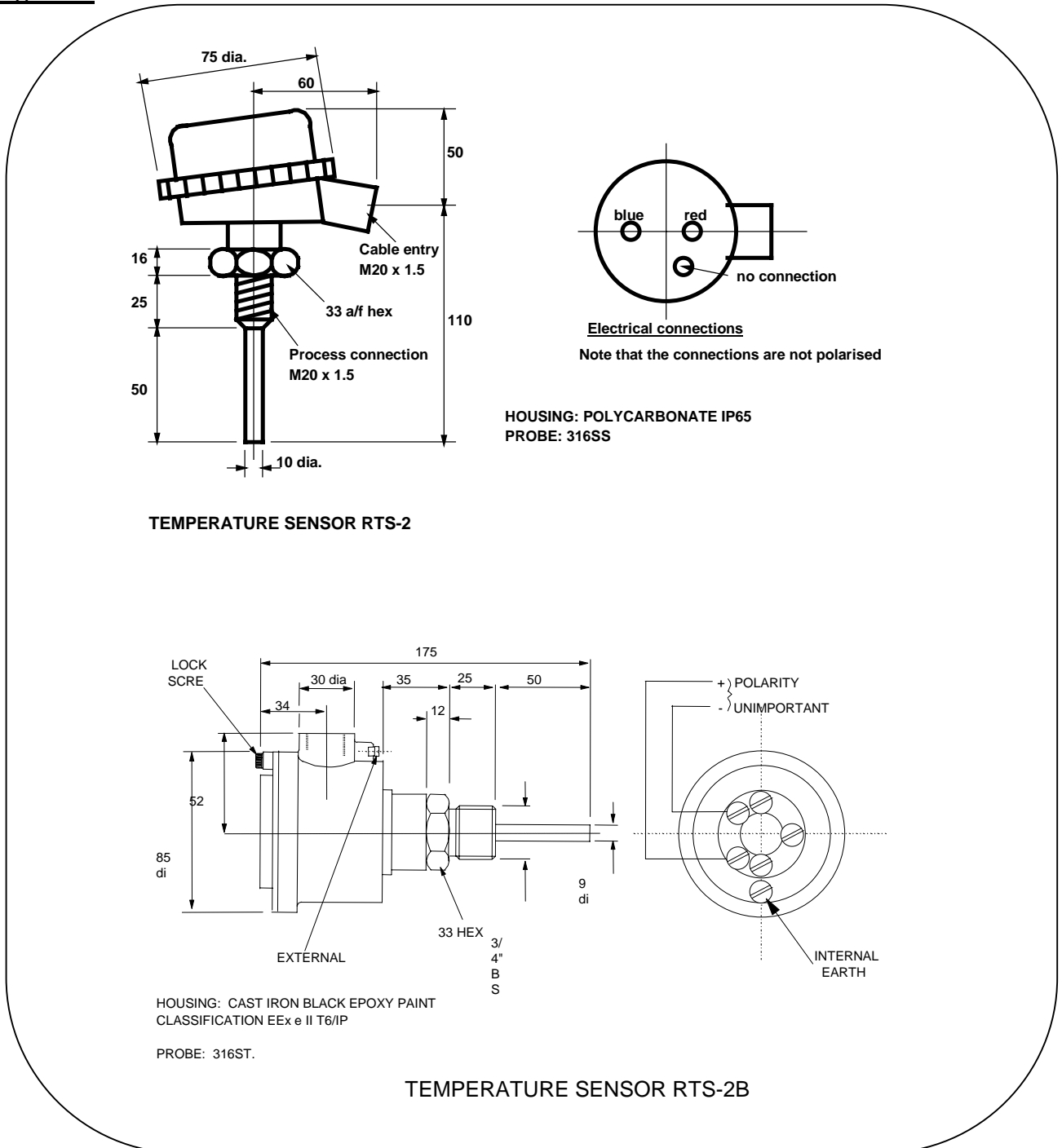

EASY START FOR LIQUIFLEX

The Liquiflex system requires programming by the operator to obtain the required measurements and control. To create a basic working system, only parameters 1 to 6 need be programmed. To become familiar with the use of the system, it is suggested that the following QUICK START guide is used before the instrument is installed.

Quick Start Guide

1. Connect power and transducer cables as defined on the instrument.

<u>ac Power Supply</u>	<u>Transducer</u>	<u>dc Power Supply</u>
[1] [2] [3]	Terminal Nos: [19] [20] [21]	[27] [28]
E N L	Black Blue Screen	+ve -ve

2. Close the front cover and secure in position before switching on the power. The instrument is supplied factory set to work in distance measurement up to 10 metres from the transducer.
3. Hold the transducer approximately 1.5 metres from a flat surface and switch on.

After a short period, the display will show the distance (e.g. 1.50) between the transducer and the surface.

If the transducer is now moved slowly towards the surface, the reading should decrease. This shows that the unit is correctly wired and is operating as expected in response to the reduction in distance.

If the reading increases as the transducer is moved towards the surface, it indicates that the unit has been previously programmed to read level not distance.

Principle of Programming

The Liquiflex has two modes:-

- a) RUN(Normal operating)
- b) PROG(Programming)

In the 'RUN' mode, the instrument is monitoring the target, displaying values, and setting outputs as programmed by the operator.

In the 'PROG' mode the operator uses the keypad in conjunction with the display to adjust the settings and to test that the unit is programmed correctly.

Keypad Definitions

The keypad consists of 20 keys which are used to programme the operation of the transceiver. These keys also have secondary functions indicated above them (See Figure 1) enabling the operator to view the results being obtained by the instrument during its normal 'RUN' cycle.

Primary Key Functions

0 - 9	Numerical Values
•	Decimal Point
—	Negative value (also used to slow down simulation)
CE	Clear Entry (also used to leave test functions Pr.75 to Pr.78.)
#	Returns display to normal 'RUN' mode after viewing secondary functions (also speeds up simulation Pr.78)
MODE	Alternates between 'RUN' and 'PROG' mode.
TEST	Displays gain in 'RUN' mode and allows parameter interrogation and simulation hold in 'PROG' mode.
'▲'	Increase parameter number (also control of simulation direction).
'▼'	Decrease parameter number (also control of simulation direction)
DSP	Display parameter number/value alternately.
ENT	Enter a new value or initiate a system test under Pr.75 to Pr.78

Active Secondary Key Functions

During normal 'RUN' mode it is possible for an operator to obtain the data defined as secondary function without interrupting normal operation, by pressing the appropriate key, i.e.

Keys 1 - 4	Show high totaliser, low totaliser, head and flow when in the OCM mode. Head will always show level.
Key 5	Relay 1. Hours energised.
Key 6	Relay 2. Hours energised.
Key 7	Relay 3. Hours energised.
Key 8	Relay 4. Hours energised.
CE	Relay 5. Hours energised.
Key 9	Relay 1. Number of times energised.
Key 0	Relay 2. Number of times energised.
•	Relay 3. Number of times energised.
—	Relay 4. Number of times energised.
'▲'	Relay 5. Number of times energised.
Test	Displays gain
ENT	Displays mA output.
DSP	Displays distance from the transducer face.
'▼'	Displays temperature.

To View Parameters

The operational programme for Liquiflex is contained within the parameters listed on Page 18. Each parameter instructs the unit to carry out a specific function. To look at the complete list of parameters and the options available see Section 4 but as an initial guide proceed as follows:-

Press 'MODE', the display will show 'PROG'. (there may be a delay of up to 6 seconds if the instrument is busy). Press '1' immediately to obtain a display of Pr.01 or the previous parameter number used.

It is now possible to key in any parameter **number**, via the keypad. To display its **value** press 'DSP'. To return to the parameter **number** press 'DSP' again.

To view a sequence of parameter numbers, enter the first one that is of interest and then press '▲' to increase the parameter number or '▼' to decrease the parameter number.

Similarly, if a parameter **value** is displayed then pressing '▲' or '▼' key will momentarily flash the next parameter **number** and then display that parameter **value**.

If a key is not pressed for a period of 30 seconds the unit will automatically return to the run mode.

Press 'MODE' to return Liquiflex to the 'RUN' mode.

To change A Parameter - Programming

Press 'MODE' to display 'PROG'.

Whilst 'PROG' is displayed press '1' and the display will show either Pr.01 or previous Pr. number.

If not Pr.01 then press '1' to obtain display of Pr.01.

Press 'DSP' to display the value of Pr.01

Press 'ENT' and the display will show 'COdE' requesting that the security code is entered.

Press '9753' to enter the factory set security code. (See Page 15 to change code).

Press 'ENT' and the display will blink and show either the default value of Pr.01 which is 2, or any other value previously programmed into it.

The unit is now ready to be programmed.

NOTE:- Whenever 'COdE' is displayed, re-enter the security code.

The display should now be showing the value entered in 'Pr.01'.

To change the value of this entry, key in the new value required and press 'ENT'. For our example press 1 and 'ENT' and the value of Pr.01 will change to 1 which means it is in level mode, i.e. measuring liquid height above datum.

Then using the '▲' key move to the other parameters that require changing.

To change the value of any other parameter either use the '▲' key to move to higher Pr numbers, or press 'DSP' and then enter the Pr number required and press 'DSP' again to display its value.

Programming Example

The following example shows how to continue programming the Liquiflex from the previous stage to achieve a simple level application including setting a high alarm.

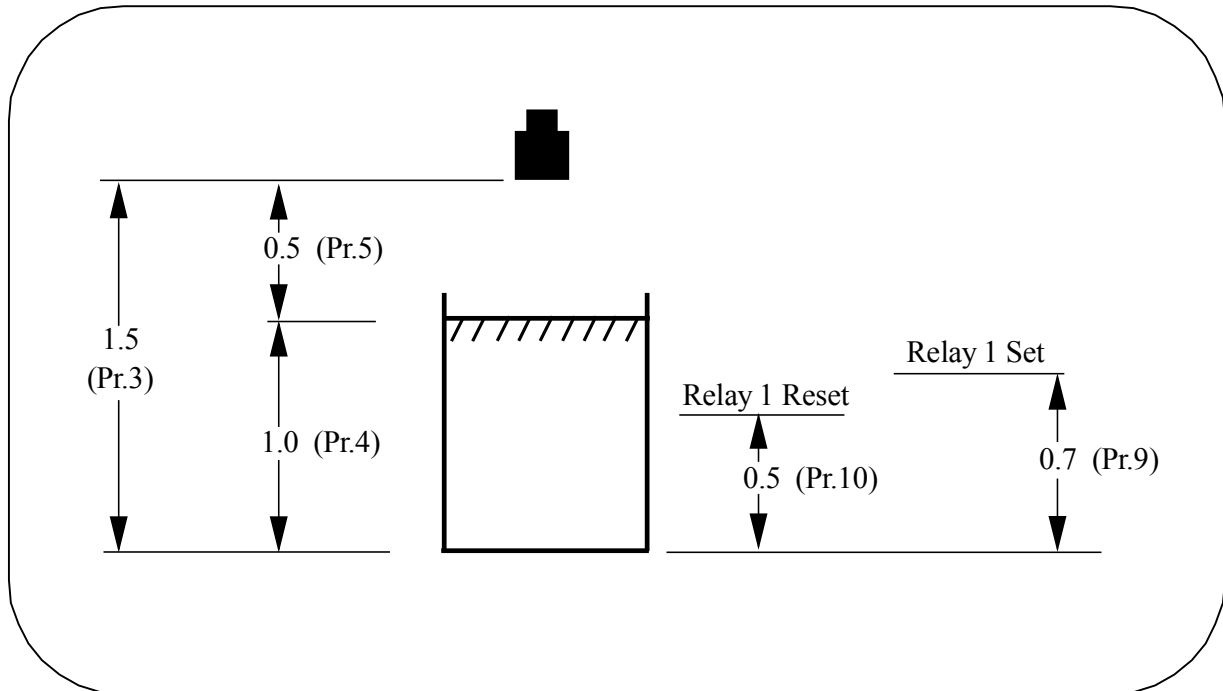

Having changed the value in Pr.01 to = 1 (level)

Press ▲	Display	Pr.02 = 2	(units in metres)
▲	Change	Pr.03 = 1.50	(empty distance)
▲	Change	Pr.04 = 1.00	(operational span)
▲	Display	Pr.05 = 0.50	(blanking distance)
▲	Display	Pr.06 = 1.00	(rate of change of level in metres)
Press Pr.08	Change	Pr.08 = 1	(relay 1 designated normally energised)
▲	Change	Pr.09 = 0.70	(relay 1 set)
▲	Change	Pr.10 = 0.50	(relay 1 re-set)
MODE	to return to normal running.		

For a full description of parameter options refer to Section 4.

Note: The display does not show the decimal point until the first decimal figure is keyed in.

Programme Checking

To check that the previous programme functions properly, hold the transducer approximately 1.5m above a surface and press 'MODE' to return to the run condition.

The display will read approximately zero.

(If it displays LOST it is because the transducer is more than the 1.5 metre (distance to furthest point) from your target. Go closer and wait for LOST to change to 0.00 and then a level).

By slowly moving the transducer towards the surface the display will increase, simulating a rising level. When the display exceeds 0.7 the relay will switch, indicated by the light on relay 1, and if the transducer is then raised, the display will decrease and the relay will reset below 0.5.

Programme Correction or Resetting to Factory Defaults.

If at any time you feel that a mistake has been made, the following routine clears the programme back to the known starting position of the factory set values shown on page 55.

It is also advisable to return to the factory default values before building a programme for a new application. This is achieved as follows:-

Press	'MODE'	to display 'PROG'
	'1'	immediately to display a Pr number.
	'99'	to display Pr.99
	'DSP'	to show '≡≡≡'
	'CE'	to clear the display
	'ENT'	to display COdE, requesting the security code.
	'9753'	
	'ENT'	the display will now show 'P.rES' followed by 't.rES' and finally '≡≡≡'
	'DSP'	to display 'Pr.99' and now the new programme can be entered.

The above is a brief introduction.

To understand programming completely it is necessary to read the detailed section describing Programming, Section 3, along with the parameter descriptions, Section 4, and the examples, Section 5, before continuing.

PROGRAMMING**Principle**

The principle of programming and the two modes 'run' and 'PROG' have already been described on page 9.

Keypad Definitions

Are fully described on page 10.

Display Descriptions

The following display codes are used:-

PROG	Precedes programme mode	
run	Precedes run mode	
Pr.XX	Parameter number	
COdE	Security code request	
'≡≡≡'	No value	
FULL	Numerical overflow of display) i.e. value too large to display.
-FUL	Negative numerical overflow) Check that Pr.43 is correct.
P.rES	Resetting to factory parameters	
t.rES	Resetting totaliser	
LOSt	Loss of echo	
tESt	System performing a requested test	
gAIN	Gain value being displayed	
HEAd	Head	
FLO	Flow	
HI.tO	Totaliser high 4 digits 9999 (----)	
LO.tO	Totaliser low 4 digits (----) 9999	
deG.C	Temperature °C	
dISt	Distance	
An.OP	Analogue output	

Security Code

The Liquiflex programme includes security code protection. Any operator can display the value of a parameter, but any attempt to enter a new value or perform a test will result in the security code being requested.

The security code is requested by the prompt of 'COdE', if the code is not entered correctly this prompt is re-displayed.

Once the code has been input correctly, it will not be required again whilst the system remains in the 'PROG' mode. The factory set value is 9753.

A new "customer's" security code, comprising 4 numerical digits, can be entered via Pr.96, providing the operator is in programme mode. The range of acceptable values is 1000 to 9999. If an invalid code is entered, the instrument will default to a code number 9753.

The code number is scrambled immediately on entry.

If you forget your security code ring your supplier for advice quoting the number stored in Pr.96.

Application Programming

The programming of Liquiflex is controlled by the parameters detailed later in this Section. Programming is easy to follow because the parameters available to the programmer fall into distinct groups:-

Pr.1 - Pr.6	Basic set up
Pr.8 - Pr.22	Relays 1 to 5 designation and settings
Pr.23 - Pr.29	Failsafe operation
Pr.30 - Pr.34	Set the analogue output
Pr.37 - Pr.39	Temperature compensation
Pr.40 - Pr.44	Volume conversion
Pr.45 - Pr.50	Open Channel Flow Metering
Pr.51 - Pr.57	Specialised Pump Control
Pr.68 - Pr.70	Select echo detection and processing
Pr.71 - Pr.74	Miscellaneous
Pr.75 - Pr.78	Test Parameters
Pr.80 - Pr.90	BS3680 Flow Parameters
Pr.95 - Pr.96	Number Stores
Pr.97 - Pr.99	Resets

It can be seen from the above which distinct groups of parameters need to be considered for a particular application. For instance, in an application to measure level, it may be necessary to consider only Pr.1 to Pr.29 which are relative to basic set-up, relays and failsafe.

It is good practice to carry out a programme reset on a new application before starting programming as this will return all parameters to factory defaults and any parameters which are not required for the new application will remain at default, ensuring that the programme runs correctly.

Default values for each parameter are shown in the parameter definition , Section 4, and in the Parameter Setting table, Page 55.

Programming

The following is the programming sequence to set up a unit for operation. If you have not done this before, refer back to Section 2, Easy Start for Liquiflex.

1. Designing a Programme

From the information contained within this manual and the knowledge of the application, produce on paper the correct values for the parameters required (use page 55 for the parameter entries).

To help you with this see the examples in Section 5 on pages 35 to 40.

Details of all the parameter options are listed on pages 19 to 34.

2. Entering a new Programme

Sequence to enter a new programme or modify the existing one.

- a. Press 'MODE'. When display shows "PROG" press '1' and then press 'DSP' followed by 'ENT'.
- b. Display will show COdE and security code must be entered (factory default is 9753. For a new code see page 15).
- c. Display will now show the value of Pr.01 or the last Pr. number used, indicating that the correct security code has been entered.

If the unit is being programmed for a **new** application it is recommended that all parameters are reset to the factory programmed values as follows:-

- d.
 1. Display Pr.99
 2. Press 'DSP' to show '≡≡≡'
 3. Press 'CE' to obtain a clear display
 4. Press 'ENT' and the display will show 'P.rES' then 't.rES' and then '≡≡≡'
 5. Press 'DSP' and enter Pr.01
 6. Press 'DSP' to display the value of Pr.01

If a modification is being made to an **existing** programme then the sequence recommences here.

- e. The new values for any parameter should be input, checking that the value is stored correctly. The parameters can be accessed in series using '▲' and '▼' keys or individually by entering the required parameter number.
- f. Before entering the 'RUN' mode, the programme can be checked by pressing Pr.78 then 'DSP' then 'ENT'. Liquiflex will now simulate the operating programme (except in differential mode) providing display, analogue output and relay functions.

CAUTION: All Liquiflex outputs will work under simulation, so ensure that external connections will not cause damage.

- g. Press 'CE' to leave simulation.
- h. Press 'TEST' to freeze and unfreeze simulation.
- i. When the programme is complete and does not require further modification press 'MODE' to return to the 'RUN' condition.

PARAMETER INDEX**LIQUIFLEX****Basic Set-up**

Pr.1	Application
Pr.2	Units
Pr.3	Empty Distance
Pr.4	Operational Span
Pr.5	Blanking Distance
Pr.6	Rate of change

Relays

Pr.8	Relay 1
Pr.9	Relay 1 Set
Pr.10	Relay 1 Reset
Pr.11	Relay 2
Pr.12	Relay 2 Set
Pr.13	Relay 2 Reset
Pr.14	Relay 3
Pr.15	Relay 3 Set
Pr.16	Relay 3 Reset
Pr.17	Relay 4
Pr.18	Relay 4 Set
Pr.19	Relay 4 Reset
Pr.20	Relay 5
Pr.21	Relay 5 Set
Pr.22	Relay 5 Reset

Failsafe

Pr.23	Failsafe R1
Pr.24	Failsafe R2
Pr.25	Failsafe R3
Pr.26	Failsafe R4
Pr.27	Failsafe R5
Pr.28	Failsafe Analogue
Pr.29	Failsafe Time Delay

Analogue

Pr.30	Analogue Output
Pr.31	Analogue Value Options
Pr.32	Analogue Datum
Pr.33	Analogue Span
Pr.34	Analogue Test

Temperature

Pr.37	Probe Enable
Pr.38	Temp. Compensation
Pr.39	Probe Test

Volume Conversion

Pr.40	Vessel Shape
Pr.41	Dimension 'H'
Pr.42	Dimension 'L'
Pr.43	Display Conversion
Pr.44	Volume Linearisation

Open Channel Flow

Pr.45	Flow Exponent
Pr.46	Max. Flow Rate
Pr.47	Time Base for Flow Rate
Pr.48	Totalise Display Conversion
Pr.49	Control of Ext. Totaliser
Pr.50	Penstock Control

Pump Controls

Pr.51	Pump Sequence
Pr.52	Duty Standby
Pr.53	Pump Exerciser
Pr.54	Pump Tolerance
Pr.55	Pump Maintenance
Pr.56	Run-on-Interval
Pr.57	Run-on-Time

Echo Detection

Pr.68	Echo Selection Algorithm
Pr.69	Check Search
Pr.70	Echo Velocity

Miscellaneous

Pr.71	Correction Value
Pr.72	Parameter Display
Pr.73	Software Revision Number
Pr.74	Reset Counter

Test Parameters

Pr.75	Digital Output Set
Pr.76	Hardware Test
Pr.77	Transmitter Test
Pr.78	Simulation

Flow BS3680

Pr.80	Calculation method
Pr.81	Flume throat width
Pr.82	Flume channel width
Pr.83	Flume throat length
Pr.84	Flume hump height
Pr.85	Weir crest width
Pr.86	Weir channel width
Pr.87	Weir crest height
Pr.88	V-notch angle
Pr.89	V-notch channel width
Pr.90	V-notch vertex height

Number Store

Pr.95	Serial Number Store
Pr.96	Security Code Store

Reset

Pr.97	Relay Hours/Starts Totaliser Reset
Pr.98	OCM Totaliser Reset
Pr.99	Full System Reset

NOTE: All other parameters are unused and should not be changed.

PARAMETER DEFINITIONS

The parameters define all the options that are available to the operator of a Liquiflex. It may be easier to read these in conjunction with the application examples on pages 35 to 40.

NOTE:- (D=) factory default entry for that parameter.

Basic Set-up

Pr.1 **Basic Application** (D=2)

- Enter
- 1 - Liquid Level Measurement
 - 2 - Distance Measurement
 - 3 - Differential Level Measurement (DLD)
 - 4 - Open Channel Flow Metering (OCM)

Pr.2 **Calibration/Display Units** (D=2)

- Enter
- 1 - Feet
 - 2 - Metres To display in percent of span,
 - 3 - Inches set Pr.40 to 1.
 - 4 - Centimetres

The system will be set to work in the specified units but the display can be made to display a percentage, a converted value or a volume (Pr.40).

NOTE: Any subsequent change of units in Pr.2 (i.e. Pr.2 = 1-4) will reset parameters Pr.3 to Pr.6 to new units and all other parameters will default to factory resets.

Pr.3 **Empty Distance** (D=10.00)

The distance from the face of transducer to the furthest point away, usually the bottom of the container or channel. Enter the distance in the units selected in Pr.2.

Resolution is a function of this parameter.

Pr.4 **Operational Span** (D=10.00)

The distance between the furthest and nearest points over which measurement is required. Enter the distance in the units selected in Pr.2

For differential applications, the value required is the maximum difference in the levels to be measured.

The relays are controlled from parameters 8-22 as follows:-

	Relay 1	Relay 2	Relay 3	Relay 4	Relay 5
Designation	Pr. 8	Pr.11	Pr.14	Pr.17	Pr.20
Set (l.e.d. on)	Pr. 9	Pr.12	Pr.15	Pr.18	Pr.21
Reset (l.e.d. off)	Pr.10	Pr.13	Pr.16	Pr.19	Pr.22

The application/relay function options are shown on the following tables:-

(D = 0 or 0.00 for all)

Pr.8	BASIC APPLICATION - RELAY FUNCTION		
Relay 1 Designation	Pr.1=1/Pr.1=2 Level/Distance	Pr.1=3 Differential	Pr.1=4 Open Channel Flow
ENTER: 0	Off	Off	Off
1	Level Alarm (e)	Level Alarm on Either Transducer (e)	Level Alarm (e)
2	Level Control (d)	Differential Alarm (e)	Level Control (d)
3	Off	Differential Control (d)	Flow alarm (e)
4	Off	Downstream Level Alarm (e)	Off
5	Off	Upstream Level Alarm (e)	Off
6	Temperature Alarm (e)	Temperature Alarm (e)	Temperature Alarm (e)
7	Loss of Echo (e)	Loss of Echo (e)	Loss of Echo (e)
8	Run Programme (e)	Run Programme (e)	Run Programme (e)
	(e) = Normally energised De-energise to alarm		(d) = Normally de-energised Energise to start (motor)
Pr.9 Relay 1 Set	For Level/Differential: ENTER values in display unit as selected at Pr.2 For Flow: ENTER values in unit selected at Pr.46 For Temperature: ENTER values in deg C. (valid only if probe fitted)		
Pr.10 Relay 1 Reset	For Loss of Echo or Run/Prog, no set or reset entries are required.		
Pr.11 Relay 2 Designation	Identical to Pr.8		
Pr.12 Relay 2 Set	Identical to Pr.9		
Pr.13 Relay 2 Reset	Identical to Pr.10		
Pr. 14 Relay 3 Designation	Identical to Pr.8		
Pr. 15 Relay 3 Set	Identical to Pr.9		
Pr. 16 Relay 3 Reset	Identical to Pr.10		
Pr.17 Relay 4 Designation	Identical to Pr.8		
Pr.18 Relay 4 Set	Identical to Pr.9		
Pr.19 Relay 4 Reset	Identical to Pr.10		

Pr.20 Relay 5 Designation	BASIC APPLICATION - RELAY FUNCTION		
	Pr.1=1/Pr.1=2 Level/Distance	Pr.1=3 Differential	Pr.1=4 Open Channel Flow
ENTER: 0	Off	N/A	Off
1	Level Alarm (e)	N/A	Level Alarm (e)
2	Level Control (d)	N/A	Level Control (d)
3	Off	N/A	Flow alarm (e)
4	Off	N/A	Off
5	Off	N/A	Totaliser Drive (d)
6	Temperature Alarm (e)	N/A	Temperature Alarm (e)
7	Loss of Echo (e)	N/A	Loss of Echo (e)
8	Run Programme (e)	N/A	Run Programme (e)
	(e) = Normally energised De-energise to alarm		(d) = Normally de-energised Energise to start (motor)
Pr.21 Relay 5 Set	For Level/Differential: ENTER values in display unit as selected at Pr.2 For Flow: ENTER values in unit selected at Pr.46 For Temperature: ENTER values in deg C. (valid only if probe fitted) For Totaliser: Refer to Pr.49 For Loss of Echo or Run/Prog, no set or reset entries are required.		
Pr.22 Relay 5 Reset			

Failsafe (D = 3 for all)

On loss of power all relays will de-energise.

For other fault conditions e.g. damaged transducer, the failsafe relay state (after time delay selected at Pr.29), is selectable:-

Pr.23 Relay 1 - Failsafe)

Pr.24 Relay 2 - Failsafe) > Enter 1 - Energise) One option for

Pr.25 Relay 3 - Failsafe) 2 - De-energise) each relay

Pr.26 Relay 4 - Failsafe) 3 - Hold state)

Pr.27 Relay 5 - Failsafe)

NOTE: Relay designated LOSS-OF-ECHO will always de-energise.
Relay 5 Failsafe is not applicable in differential or OCM mode.

Pr.28 Analogue and Display Failsafe (D=3)

Enter 1 - Low
2 - High
3 - Hold Value

Pr.29 Failsafe Time Delay (D=120)

Enter value (in seconds) before unit goes to selected failsafe positions.
Minimum value is 30 seconds.

Analogue**Pr.30 Analogue Output (D=1)**

- Enter 1 - 4-20mA)
 2 - 20-4mA) > related to span (Pr.4) or Pr.33
 3 - 0-20mA)
 4 - 20-0mA)
 5 - 4-20mA) > will over-range 0-24mA if normal span
 6 - 0-20mA) (Pr.4) is exceeded

The output represents different variables depending on the application mode selected at Pr.1

Limits are defined by Pr.4

Pr. 1 Entry	Application	Output Proportional To
1	Liquid Level	a) Liquid Level b) Liquid volume if Pr.40 is used
2	Distance	a) Target distance b) Space volume if Pr.40 is used
3	Differential (DLD)	Differential level. (The unit can differentiate between positive and negative differentials. (See Pr.31)
4	Open Channel Meter (OCM)	a) If Pr.31 = 1 output proportional to head b) If Pr.31 = 2 output proportional to flow

NOTE: Refer to Pr.34 for output test.

Pr.31 Analogue Value Options (D=1)**In differential mode (Pr.1 = 3)**

- Enter 1 - difference of two levels - Pr.4 represents maximum differential in levels
- 2 - upstream level - Pr.4 represents the difference between upstream empty distance Pr.3 and maximum upstream level.
- 3 - downstream level - Pr.4 represents the difference between downstream empty distance Pr.3 and maximum downstream level.

In OCM mode (Pr.1 = 4)

- Enter 1 - for measured head (depth of liquid)
 2 - for calculated flow

Pr.32 Analogue Datum (D=0.00)

If an analogue output is required with a zero different from the measurement zero (Pr.3) then an offset defined as a percentage of the measurement span/flow/volume etc., can be entered here.

Pr.33 Analogue Span (D=100)

If an analogue output is required with a span different to that defined for the measurement (Pr.4) then an alternative value defined as a percentage of the measurement span/flow/volume etc., can be entered here. A value of zero is ignored.

Pr.34 Analogue Output Test (D=0.00)

This parameter can be used to examine the last analogue output value set up by the instrument. Also any value in the analogue output range can be entered for loading to the current output, and can be measured at the output terminals, to test the external analogue circuitry.

Temperature Compensation**Pr.37 Temperature Sensor Enable** (D=1)

1 = No sensor attached
2 = Sensor attached

Pr.38 Compensating Temperature (D=20°C)

If no probe is fitted the vessel temperature may be entered here.

Pr.39 Temperature Sensor Test (D=0.00)

Displays the sensor resistance in K Ohms. Typically 9.5 at 20°C.
If value shows '0.00' after switching 'Off' and 'On' then either no sensor is connected, or there is a short circuit or open circuit in the system.

Volume Conversion

Pr.40 Vessel Shape (D=0)

- '0' = no volume conversion
 1 = flat bottomed vessel and percentage of span
 2 - 7 = standard shapes as shown below
 8 = vessel linearisation (see Pr.44)

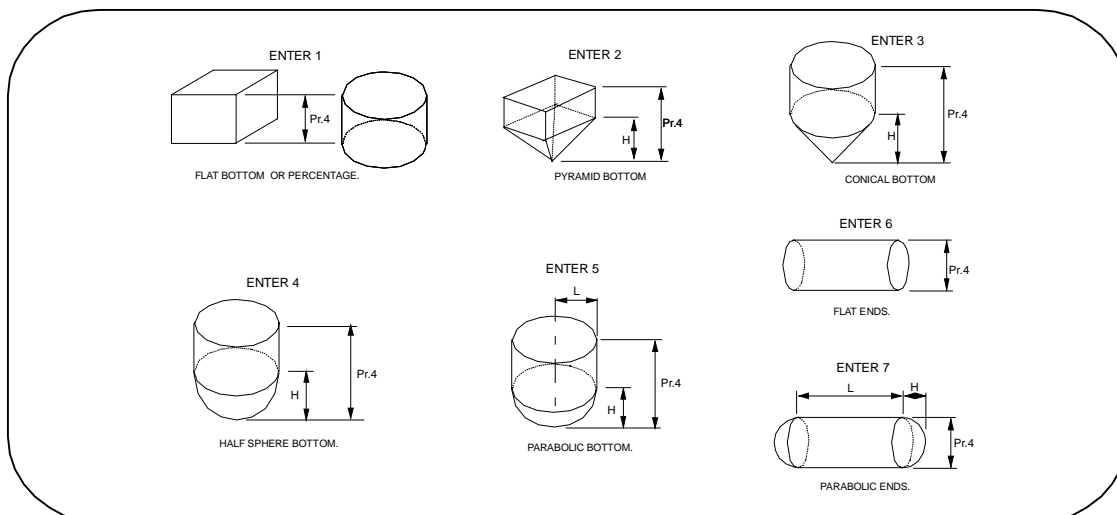

Pr.41 Vessel Dimension H (D=0.00)

Enter H where indicated above in units selected at Pr.2.

Pr.42 Vessel Dimension L (D=0.00)

Enter L where indicated above in units selected at Pr.2

Pr. 43 Display Conversion (D=1.00)

If Pr.40 entry is between 1 - 8 then enter - full scale display \div 100
 e.g. if 100% = 2000 litres and display required in litres then
 set Pr.43 to $2000 \div 100 = 20$.

To display in any unit enter any value from '0.001' to '99.99'

NOTE: Display cannot be more than 4 digits. If it is necessary to measure 20,000 gallons, then display in thousands of litres (or cubic metres) by dividing 20 by 100 = 0.2.

Pr.44 Linearisation (D= '≡≡≡')

This function allows non-standard flumes and vessels to be characterised. For full details please refer to Appendix 1, pages 46 to 50.

Open Channel Flow Metering

Pr.45 Flow exponent (D=1)

Enter the required value for the open channel flow device being used.

e.g.	<u>Flow Device</u>	<u>Enter</u>
	Unity	1
	Rect. flume 3/2	2
	Rect. weir 3/2	2
	V-notch weir 5/2	3
	Special	4 (Refer to Pr.44)
	BS3680	Refer to Appendix 4
	Parshall Flumes	5-14 Refer to Appendix 6

Pr.46 Maximum Flow Rate (D=0.00)

Enter the maximum flow rate in units per second, per minute, per hour or per day, corresponding to maximum head, set at Pr.4 and then define the time base at Pr.47.

Pr.47 Time Base of Maximum Flow Rate (D=1)

Enter the value corresponding to the flow rate time base.

- Enter 1 = units per second
 2 = units per minute
 3 = units per hour
 4 = units per day

Pr.48 Totaliser Display Conversion (D=0)

Used to totalise on the display in flow units larger than those entered at Pr.46 (max. flow rate).

- Enter 0 - Multiples by 1
 1 - Multiples by 0.1
 2 - Multiples by 0.01
 3 - Multiples by 0.001
 4 - Multiples by 0.0001
 5 - Multiples by 0.00001
 6 - Multiples by 0.000001
 7 - Multiples by 0.0000001

e.g. If Pr.46 is entered as litres, at Pr.48 enter '3' to totalise the flow in cubic metres.

Pr.49 Control External Counter (D=0.00)

If Pr.20 is set to 5, "Totaliser Drive", then enter the amount which each relay trip is to represent in totalised units. See example 5 on page 39.

e.g. If "litres" entered at Pr.46 and Pr.48 is '0' then to totalise in cubic metres enter 1000.

If an entry is made at Pr.48 for the internal totaliser then to use the same unit for an external counter enter '1'.

After making entries in Pr.49, go to Pr.98 to clear and initiate totaliser.

Pr.50 Penstock Control (D=1)

Enter 1 - No drive
2 - Penstock control

The control system uses relays 1 and 2 to drive a penstock up and down respectively to maintain the flow in a channel within certain limits.

The designations for relays 1 and 2 are ignored, but the following values have to be set.

Pr.9 : Top flow limit) In units defined by
Pr.10 : Bottom flow limit) Pr.46 entry
Pr.12 : Width of drive pulse (seconds)
Pr.13 : Time between drive pulses (seconds)

See example 6 on page 40.

The penstock drive consists of a pulse train of variable time base which drives the penstock up and down.

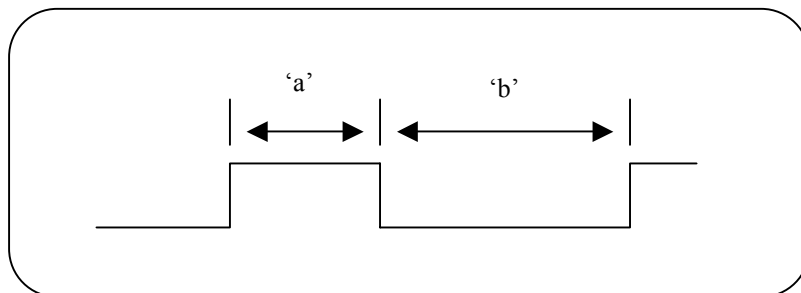

The time 'a' is set by Pr.12 and 'b' is set by Pr.13 in seconds, this allows any shape drive train to be defined.

The control will maintain the flow between two limits, a high limit set by Pr.9 and a low limit set by Pr.10.

If the flow exceeds the value in Pr.9 relay 2 drives the penstock down. If the flow is below the value in Pr.10 relay 1 drives the penstock up. See Example 6.

Pump Controls

Pr.51 Pumps Sequencing (D=1)

In order to even out the wear of pumps it is possible to alternate the sequence in which pumps are used.

- Enter
- 1 - Sequence by set points (i.e. no alternation).
 - 2 - Alternate RL1 and RL2
 - 3 - Alternate RL1, RL2 and RL3
 - 4 - Alternate RL1, RL2, RL3 and RL4
 - 5 - Alternate RL1, RL2, RL3, RL4 and RL5

NOTE:

When using Pr.51 with Pr.52 set to 2-5; -

- 1. All switch-off points should be set at the same level**
- 2. Do not include alarm function relays in duty/standby routines.**

Pr.52 Duty/Assist/Standby Pump Control (D=1)

Duty assist is where pumps are switched on by set point, and kept on to assist earlier pumps. Duty standby is where only one of the pumps specified for duty can be on at a time, i.e. when the set point for the second pump is reached and it switches on, the first pump will switch off.

- Enter
- 1 - Duty/assist operation
 - 2 - Duty/standby on pumps 1 and 2
 - 3 - Duty/standby on pumps 1, 2 and 3
 - 4 - Duty/standby on pumps 1, 2, 3 and 4
 - 5 - Duty/standby on pumps 1, 2, 3, 4, and 5

The turn-off points for the pumps can all be the same, or they can be different depending on the chosen "Set" and "Reset" values for each relay – unless using alternating sequence at Pr.51.

Pr.53 Pump Exerciser (D=1)

To use this facility, first select alternating duty options 2 to 5 in Pr.51, depending on the number of pumps installed.

Enter the number of starts assigned to Pump 1 before the sequence switches to allow the other pumps to be exercised in turn.

Pr. 54 Pump Tolerance (D=1)

In applications where a greasy topped liquid is being pumped, problems may occur due to build-up of grease at the levels where pumping starts. It is usually necessary for this to be cleared manually. To avoid this, varying the "turn on" point for the pumps by $\pm 10\%$ of the set point value causes the build-up to occur over a larger area, significantly reducing the maintenance problem.

- Enter
- 1 - No tolerance applied to pumps
 - 2 - Tolerance applied to all pumps

NOTE:

The pump 'reset' points must be outside the tolerance band of the set points and blanking.

Pr.55 Pump Maintenance Dropout (D=0)

The removal of one pump for maintenance can necessitate a great deal of readjustment to ensure correct control. Pr.55 removes this need by allowing one pump to be removed without affecting the control levels. Pumps are re-assigned downwards so that the highest level is not used, therefore, normal control levels are maintained for lower level setting.

Enter 0 - All pumps in
 1 - Drop out pump 1
 2 - Drop out pump 2
 3 - Drop out pump 3
 4 - Drop out pump 4
 5 - Drop out pump 5

- NOTE:**
- a. The system assumes that the lower numbered pumps turn on first.
 - b. CAUTION - A PUMP NOT INCLUDED IN AN ALTERNATING SEQUENCE BUT PROGRAMMED INTO THE FIXED PART OF THE SEQUENCE WILL BE SUBSTITUTED INTO THE ALTERNATING SEQUENCE TO REPLACE A PUMP DROPPED OUT.
 - c. This feature should not be used if the relays are being used for a mixture of pump control and alarm functions.

Pr.56 Pump Run-on Interval (D=0.00)

When submersible pumps are used, it may be necessary to pump down occasionally to clear the sludge from the bottom of the well. This feature is controlled by Pr.56 and Pr.57. Once in every interval defined by Pr.56, the pump will run-on for the time period defined by Pr.57.

Enter the time interval in hours between each run-on cycle.

Pr.57 Pump Run-on Time (D=0)

Enter the pump running time in seconds. Maximum 120 seconds.

Only one run-on cycle occurs per interval as set by Pr.56.

- NOTE:**
- a. Caution is required when choosing a value for pump run-on time, as extended pump run-on can lead to cavitation, causing air locks or pump damage.
 - b. As overflow can occur, **do not** use pump run-on for pump up operation, set Pr.56 and Pr.57 to zero.
 - c. Care should be taken if pump sequence and pump run-on are defined together, as pump run-on will be assigned to the last pump to turn off, which could be any of those in the sequence.

Echo Detection

Pr.68 Echo Processing Algorithm (D=2)

The system has two echo extraction techniques, which are capable of determining the "true" echo for the majority of applications where an echo is present.

Enter 1 = All vessel viewing. This technique continuously looks for echoes over the complete vessel. It is suited to applications that have very rapid level changes but it is more sensitive to parasitic echoes.

Enter 2 = Windows. This technique positions a narrow 'window' around the target it is tracking to enable it to ignore a large amount of spurious noise.

Pr.69 Check Search (D=1)

Enter 1 = Not used
2 = Included

Check search should be used where fill rates can sometimes be greater than that entered at Pr.6, or if the transducer is liable to be submerged.

Pr.70 Echo Velocity (D=344.1 i.e. speed of sound in air at 20°C)

If operating through any medium other than air, enter the velocity of sound through that medium in metres per second.

Miscellaneous**Pr.71 Correction Value** (D=0.00)

Both negative and positive values can be input. This value must be entered in the units selected at Pr.2.

This parameter has two uses:

1. It can be used to correct minor reading errors on the display
2. It can be used to prevent loss-of-echo when the target can go further away from the transducer than the desired span.
 - e.g. a) When a channel floor is lower than the zero point of a "V" notch weir.
 - b) To set an elevated zero level in a vessel which is not normally completely emptied.

Add the extra depth to Pr.3 and enter minus the extra depth at Pr.71 in the units selected at Pr.2

Pr.72 Parameter Display (D=0)

The system will display continually the value of:

Gain	-	by entering 67
Temperature	-	by entering 38
Analogue output	-	by entering 34.

It can be used only for commissioning as it will be lost on power down. It cannot be used in OCM mode.

Pr. 73 Software Revision Number

Displays the revision number of the software, e.g. LA.14.

Pr.74 Reset Counter

This count value gives the number of times that the system has been powered down or reset since the last time the counter was zeroed. It is useful for checking if the power supply is erratic.

Test Parameters

Pr.75 Digital Outputs (D=0)

To aid commissioning and the testing of external wiring, it is possible to define the status of all five relays when in 'PROG' mode.

Press 'DSP' then:-

Enter 0 - To de-energise all relays
 ADD 1 - To energise relay 1
 ADD 2 - To energise relay 2
 ADD 4 - To energise relay 3
 ADD 8 - To energise relay 4
 ADD 16 - To energise relay 5
 e.g. To energise relays 2 and 5 enter '18'

The defined relay state will be maintained until over-written or until 'PROG' mode times out (6 minutes). The time period can be extended by pressing a key during this period to reset the time-out counter.

Pr.76 Hardware Test

Press 'DSP' then 'ENT' to test LEDs/LCD and relays. The LCD will flash all segments, and the LEDs will count up in binary. Press 'CE' to end test, or let it time out.

CAUTION: DO NOT USE THIS TEST WHEN CONNECTED TO PUMPS
 OR RELAYS. USING THIS PARAMETER WILL OPERATE
 ALL RELAYS AND MIGHT START PUMPS, ALARMS ETC.

Pr.77 Transmitter Test

Press 'DSP' then 'ENT', the transmitter should pulse continuously, (made visible by the neon). By the use of an oscilloscope the return echo can be observed if required.

Also useful to ascertain if a transducer is correctly connected, as it will 'click' repeatedly. Press 'CE' to end.

Pr.78 Simulation

The value displayed will depend on the value set in Pr.01.

Press 'ENT' to simulate the operation of the instrument as set up between Blanking and Empty distance. The display will depend on mode set in Pr.01.

Mode = 1 (liquid level)	-	LEVEL
= 2 (distance measurement)	-	DISTANCE
= 3 (differential)	-	NO SIMULATION AVAILABLE
= 4 (OCM)	-	LEVEL

It will set all LEDs/relays and the current output as programmed. Therefore, care must be taken if the instrument is wired into other instruments or controls. The displayed value, on which all relays are operated, is that which is set by the operator.

The initial speed of the simulation is that set into Rate of Change (Pr.6) this can be increased by a factor of 2 by pressing the '#' key and the key can be pressed 6 times (x64). To reduce the speed press the '-' key, the speed cannot be reduced below that defined by Rate of Change, Pr.6.

The direction of the simulation can be changed by using the '▲' and '▼' keys, which one has to be pressed depends on the set up. The simulation can be stopped and re-started using the 'TEST' key. Press 'CE' to end.

Number Store

Pr.95 Serial Number (Viewable only)

This parameter displays the serial number of the Liquiflex unit.

Pr.96 Security Code Store

A new security code can be entered at this parameter, but after entry it is scrambled. Refer to Hycontrol if you forget your security code and quote the number displayed here.

Resets

Pr.97 Relay Hours/Starts Totaliser Reset (D= '≡≡≡')

The totalisers are cleared by entering:

Pr.97 and 'DSP'	to show '≡≡≡'
Press CE	to clear the screen
Press Enter	to request 'COdE'
Enter 9753	
Press Enter	to show 't.rES' and '≡≡≡'

Pr.98 Clear the OCM Totaliser i.e. HI.TO and LO.TO (D= '≡≡≡')

The totalisers are cleared by entering:

Pr.98 and 'DSP'	to show '≡≡≡'
Press CE	to clear the screen
Press Enter	to request 'COdE'
Enter 9753	
Press Enter	to show 't.rES' and '≡≡≡'

Pr.99 Return to Factory Default

Press	'MODE'	to display 'PROG'
	'1'	immediately to display 'Pr.01' or previous Pr. number.
	'99'	to display Pr.99
	'DSP'	to display '≡≡≡'
	'CE'	to clear the display
	'ENT'	to display 'COdE' requesting the security code* (see note)
	'9753'	and 'ENT' to display P.rES followed by t.rES, and then '≡≡≡'
	'DSP'	to display 'Pr.99' and now the new programme can be entered.

NOTE * Enter your own security code number if you have changed it from factory setting of 9753.

LIQUIFLEX EXAMPLES**Example 1****Level Measurement Mode** (Pr.1 = 1)

Applications for this mode are, Level Measurement, Contents Measurement and Pump Control.

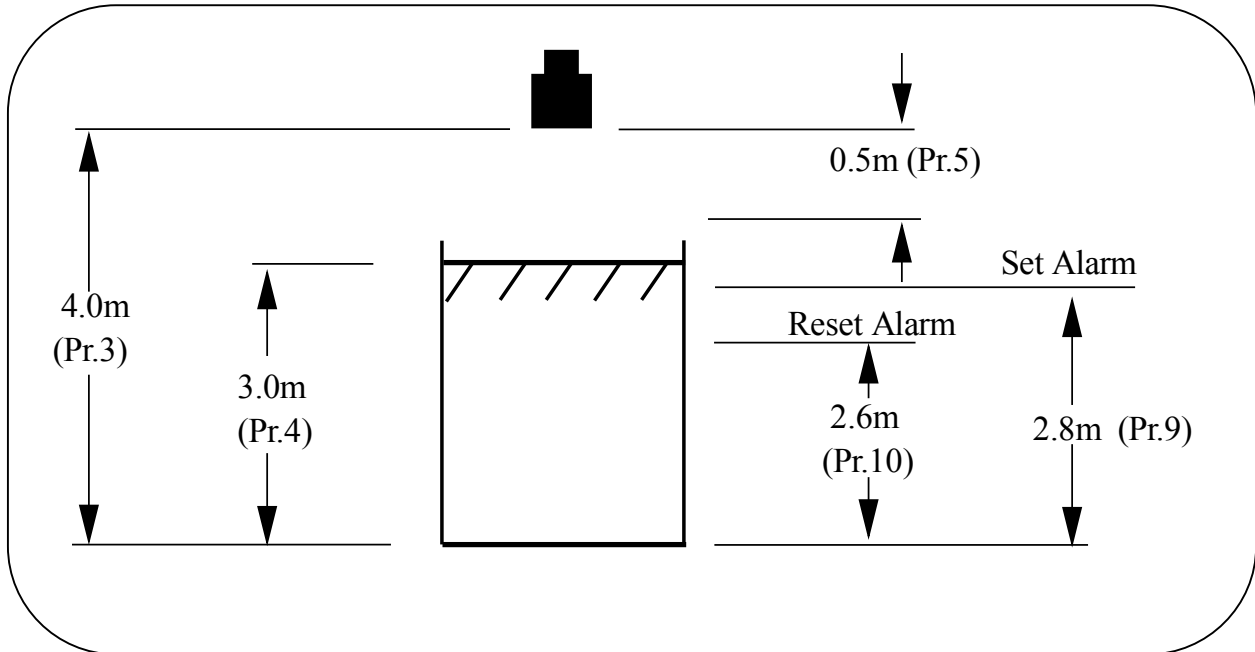

The application:-

To measure and display the level of liquid in metres.

Maximum level 3m.

Fill rate 0.1 metre/min.

Alarm if level exceeds 2.8 metres

0-20mA signal proportional to level.

Pr.1	=	1	Defines level measurement
Pr.2	=	2	Programme units are metres.
Pr.3	=	4	Distance from transducer to zero level.
Pr.4	=	3	The span, based on zero level.
Pr.5	=	0.5	Blanking zone into which level should not rise.
Pr.6	=	0.1	The maximum rate of change of liquid level in metres/minute.
Pr.8.	=	1	Relay 1 to alarm on level (normally energised)
Pr.9.	=	2.8	Relay 1 to de-energise at 2.8 metres to indicate high alarm.
Pr.10	=	2.6	Relay 1 to re-energise at 2.6 metres to clear the high alarm.
Pr.23	=	3	Hold alarm indication (relay 1) on failsafe.
Pr.28	=	3	Analogue output holds on failsafe.
Pr.30	=	3	0-20mA output fixed to span (Pr.4).
Pr.78			Simulate the programme

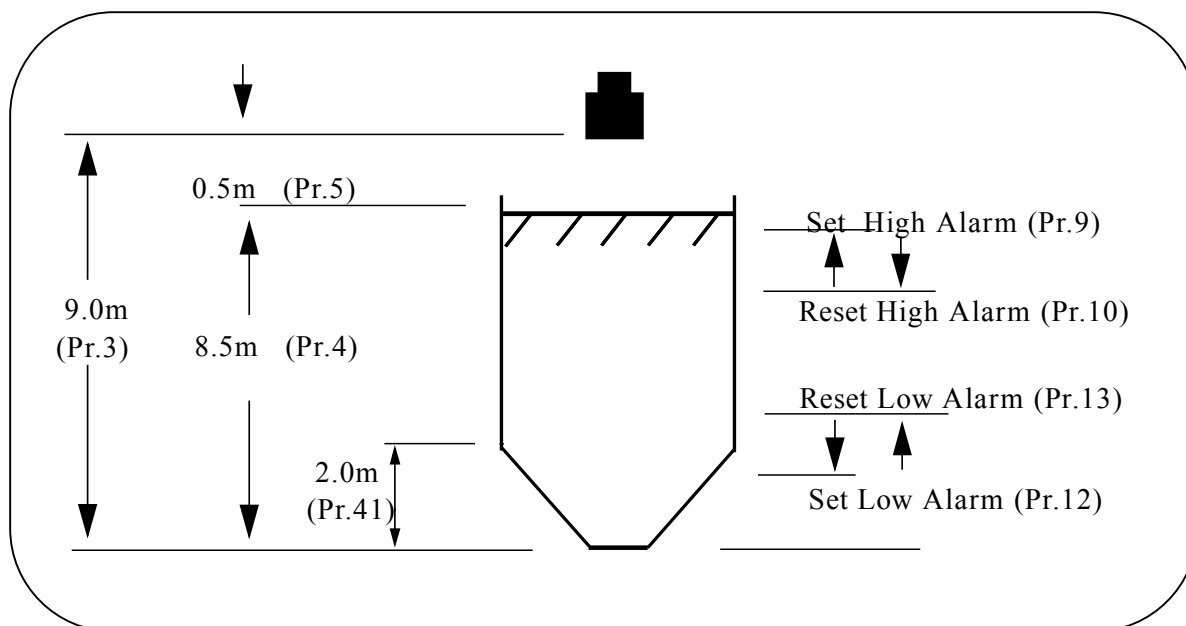
Example 2**Contents Measurement with Volumetric Conversion** (Pr.1 = 1)

The application:

To measure the level in a conical bottomed cylindrical tank. Dimensions as shown.

Total volume of tank = 120m³ when level is 8.5m.

Output/display in m³.

Analogue output to be 0-20mA proportional to volume in tank.

High alarm at 90m³ volume.

Low alarm at 10m³ volume.

- | | | | |
|-------|---|-----|---|
| Pr.1 | = | 1 | Defines level measurement. |
| Pr.2 | = | 2 | Programme in metres, display/control in volume. |
| Pr.3 | = | 9 | Transducer to zero level = 9 metres. |
| Pr.4 | = | 8.5 | The span over which measurement is required. |
| Pr.5 | = | 0.5 | Blanking zone into which level should not rise. |
| Pr.6 | = | 10 | The rate of change of level will not exceed 10 metres per minute. |
| Pr.8 | = | 1 | Relay 1 to alarm on volume (normally energised). |
| Pr.9 | = | 90 | Relay 1 de-energises at 90m ³ . High alarm on. |
| Pr.10 | = | 85 | Relay 1 energises at 85m ³ to clear high alarm. |
| Pr.11 | = | 1 | Relay 2 to alarm on volume (normally energised). |
| Pr.12 | = | 10 | Relay 2 de-energises at 10m ³ . Low alarm on. |
| Pr.13 | = | 15 | Relay 2 energises at 15m ³ to clear low alarm. |
| Pr.30 | = | 3 | Analogue output to be 0-20mA fixed to span. |
| Pr.40 | = | 3 | Define vessel as conical bottomed. |
| Pr.41 | = | 2.0 | Define the depth of cone as 2.0m. |
| Pr.43 | = | 1.2 | Define total capacity 120m ³ . |
| Pr.78 | | | Simulate the programme. |

Example 3**Pump Control**

(Pr.1 = 1)

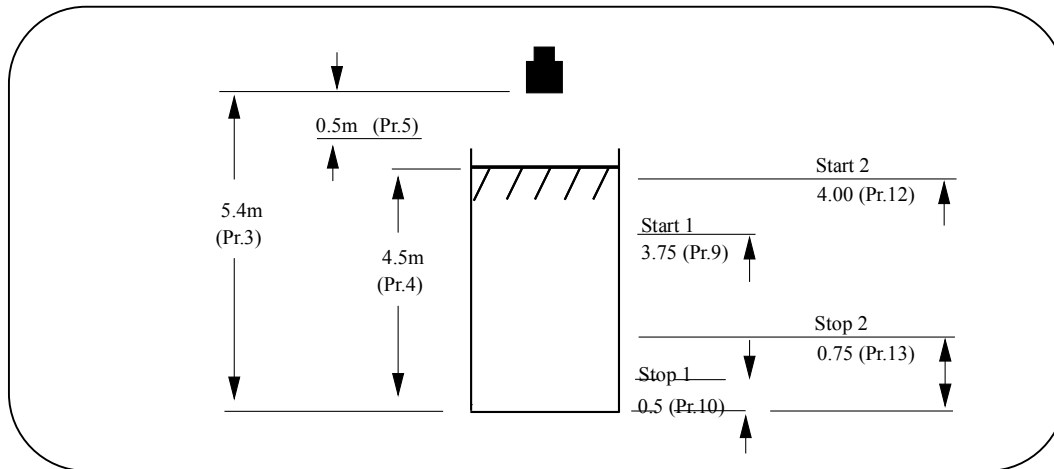

The application:

- 2 pump control, pump down in a wet-well, duty-assist operation.
- Alternate pump duty to reduce wear.
- 4-20mA to remote indicator.
- Loss-of-Echo indication to telemetry.
- Display actual level in metres.

Pr.1	=	1	Defines level measurement
Pr.2	=	2	Programme in metres, display in metres.
Pr.3	=	5.4	Transducer to zero level = 5.4m.
Pr.4	=	4.5	The span over which measurement is required.
Pr.5	=	0.5	Blanking into which the liquid will not rise.
Pr.6	=	1.5	Max. rate of level change 1.5m/min.
Pr.8	=	2	Relay 1 control on level (normally de-energised)
Pr.9	=	3.75	Relay 1 energises at 3.75m to turn pump 1 on.
Pr.10	=	0.5	Relay 1 de-energises at 0.5m to turn pump off.
Pr.11	=	2	Relay 2 to control on level (normally de-energised)
Pr.12	=	4.0	Relay 2 energises at 4.00m to turn pump 2 on.
Pr.13	=	0.75	Relay 2 de-energises at 0.75m to turn pump 2 off.
Pr.17	=	7	Relay 4 assigned to indicate loss-of-echo to the telemetry system.
Pr.23	=	2	Switch pump 1 off on failsafe.
Pr.24	=	2	Switch pump 2 off on failsafe.
Pr.28	=	1	Analogue output to 4mA on failsafe.
Pr.29	=	30	Failsafe delay 30 seconds.
Pr.30	=	1	Analogue output to be 4-20mA fixed to Pr.4.
Pr.51	=	2	Alternate pump duty.
Pr.78			Simulate the programme.

Example 4**Differential Mode**

(Pr.1 = 3)

In the differential mode, the transceiver drives two transducers to measure the difference in levels by subtracting the downstream level from the upstream level. Please see connection diagram Figure 7 for transducer wiring.

The upstream transducer should be chosen to give a positive differential value.

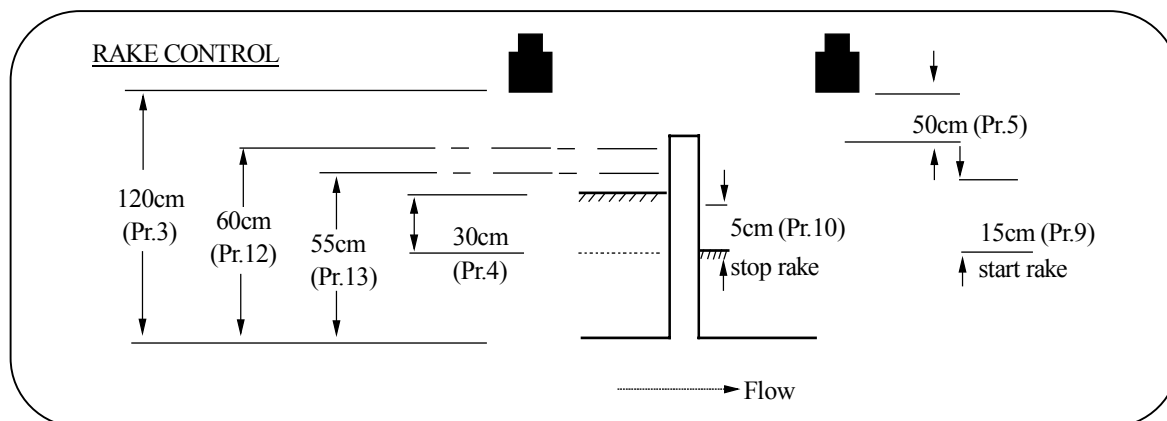

The application:

- Start rake when differential reaches 15cm.
- Stop rake when differential falls to 5cm.
- Maximum differential 30cm.
- Alarm if level on upstream side exceeds 60cm.
- Loss-of-Echo indication to telemetry system.
- 4-20mA signal proportional to differential.

- Pr.1 = 3 To define differential level measurement.
- Pr.2 = 4 As distances are small programme in cms.
- Pr.3 = 120 The distance from bottom of channel to transducers in cms.
- Pr.4 = 30 The maximum differential span in cms.
- Pr.5 = 50 Blanking zone in cms.
- Pr.6 = 100 The maximum rate of change of level in cms.
- Pr.8 = 3 Relay 1 designated for differential control.
- Pr.9 = 15 Relay 1 energises at differential 15cm to start rake.
- Pr.10 = 5 Relay 1 de-energises at differential 5cm to stop rake.
- Pr.11 = 5 Relay 2 to alarm on an upstream level.
- Pr.12 = 60 Relay 2 de-energises at 60cm high alarm.
- Pr.13 = 55 Relay 2 energises at 55cm to clear high alarm.
- Pr.17 = 7 Relay 4 assigned to indicate loss-of-echo to the telemetry system.
- Pr.23 = 2 Switch rake off on failsafe.
- Pr.24 = 3 Hold alarm level indication on failsafe.
- Pr.28 = 3 Analogue output holds on failsafe.
- Pr.29 = 120 Failsafe time is left at default of 120 seconds.
- Pr.30 = 1 4-20mA output fixed to span (Pr.4)
- Pr.97 = (optional) This counts the number of times the rake is turned on, and how many hours it has been energised.

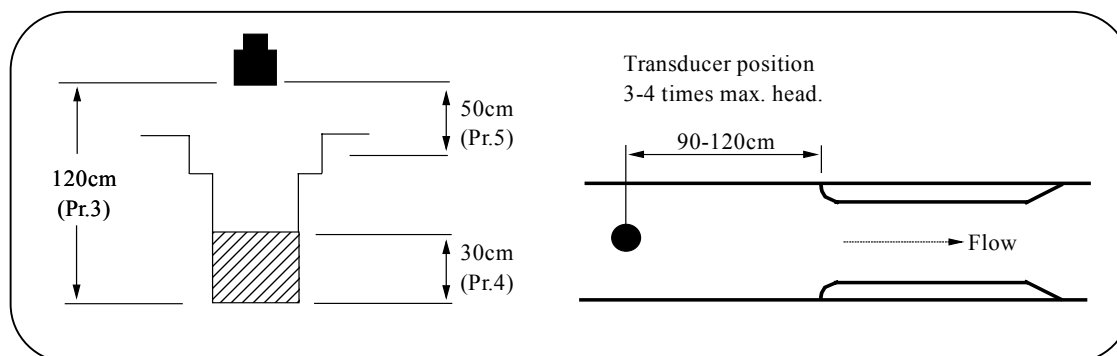
Example 5**Open Channel Flowmeter** (Pr.1 = 4)

The application:

Rectangular flume, with a maximum flow of 39 litres per second at head 30cm.
 Loss-of-Echo indication to telemetry system.
 4-20mA signal proportional to flow.
 Totalise flow and provide pulsed output to external totaliser every 1000 litres.
 Display flow reading.

- Pr.1 = 4 To define open channel flow metering.
 Pr.2 = 4 As distances are small, work in cms.
 Pr.3 = 120 Distance of transducer from bottom of channel.
 Pr.4 = 30 Level at which maximum flow rate value is defined.
 Pr.5 = 50 Blanking zone into which level will not rise. It is suggested that this is above the top of the channel to allow the system to continue reading up to that level.
 Pr.6 = 50 Rate of change of level 50cm/min.
 Pr.17 = 7 Relay 4 assigned to indicate loss-of-echo to the telemetry unit.
 Pr.20 = 5 Relay 5 to operate as external totaliser switch.
 Pr.28 = 3 Analogue output "holds" on failsafe, as factory set.
 Pr.29 = 120 Failsafe time is left at default of 120 seconds.
 Pr.30 = 1 4-20mA output fixed to span (Pr.4).
 Pr.31 = 2 Analogue output represents flow rate.
 Pr.37 = 2 Probe enable if Temperature Compensation is used.
 Pr.45 = 2 To define that a rectangular flume is being used.
 Pr.46 = 39 Defines the maximum flow is 39 litres.
 Pr.47 = 1 Flow in Pr.46 is in litres per second.
 Pr.48 = 3 To avoid totaliser overflow, totalise in cubic metres rather than litres.
 Pr.49 = 1 To set external totaliser to same as internal totaliser.
 Pr.78 Simulate the programme.
 Pr.98 Clear and initiate the totalisers.

NOTE: In normal 'RUN' mode display will always show Flow.
 Instantaneous readings of "High total", "Low total", "Head" and "Flow" can be obtained by pressing keys 1 to 4. The display will revert back to Flow after 15 seconds.

Example 6**Open Channel Flowmeter With Penstock Control** (Pr.1 = 4)

The application:

As example 5, but additionally to control a penstock via Relays 1 and 2 to modulate flow between 25 and 30 litres per second.

ENTER: Pr.1 - Pr.6 as example 5, then go to Pr.9

Pr.9 = 30 Defines top flow limit 30 litres per second.

Pr.10 = 25 Defines low flow limit 25 litres per second.

Pr.12 = 8 Duration of penstock drive pulse is 8 seconds.

Pr.13 = 4 Time between drive pulses is 4 seconds.

ENTER: Pr.14 - Pr.48 as example 5, then go to Pr.50.

Pr.50 = 2 To initiate penstock control.

ENTER: Pr.78 as example 5.

ENTER: Pr.98 as example 5

COMMISSIONING FAULT FINDING

Basic Hardware

A) The display is blank or frozen, the leds are unlit and the neon does not fire:-

1. Ensure that power is being supplied to the board, and that it is correctly wired. Refer to figure 2, on Page 3.
2. Check fuses F5 (ac) and F6 (dc)
3. Check that the supply voltage is within specified levels (See Section 1 Page 3). A large voltage drop can cause the unit to lock to show last distance or level reading.

B) The fuse blows continuously:-

1. Power down and fit a new fuse - refer to Page 3
Disconnect all cabling from the unit except for the power lead. If the fuse does not blow on power up, there is a fault in the external wiring.
2. Check that the power supply is within specified limits -refer to Page 3.
3. Check the enclosure for metal debris which may be under the lower PCB.

C) The system powers up, but displays '8888':-

1. Check; with power off, that an Eprom is fitted at U7 and that the chip has not vibrated free from its socket.

D) The display shows 'LOSt':-

1. Check the transducer wiring and connections to the instrument. Note that different connections are used if a temperature compensated transducer is connected. See Figure 2, Page 3.

2. Check whether the neon light adjacent to terminal 22 is flashing. If it is proceed to number 3, if it is not then :-
 - a: Disconnect the transducer: If the neon now lights then there is a short circuit in the cabling.
 - b: If the neon does not light the transmission fuse may have blown. Check F1 and F2 T80mA fuses on the bottom PCB.
 - c: If the unit still shows 'LOSt' check that you can hear the transducer "clicking" when close to the ear.
 - d: If the transducer cable has been extended, disconnect and remove the transducer and connect it direct to the Liquiflex. If the unit now operates, recheck the extension cable connections and routing, avoiding power cables. Re-install the transducer checking that its aim is perpendicular to the target surface.
 - e: If the transducer does not click proceed to 5.
3. Is there a target within the empty distance specified in Pr.3? This is particularly important if temperature variations are experienced and no compensation is applied.
4. Is the vessel empty with a conical, parabolic, sloping or spherical bottom? This commonly causes loss of echo if the transducer cannot be mounted over the centre of the vessel. When the vessel becomes empty the pulse from the transducer hits the sloping sides of the bottom section and the signal is not reflected back to the transducer. Under this condition the display will indicate 'LOSt' but the failsafe designation will operate until product returns and the system will automatically recover and track level. If the transducer cannot be mounted centrally, the problem may be overcome by the installation of a target plate.
5. Connect a known good transducer to the instrument and check the operation. If the known transducer gives a good signal check the instrument's gain by pressing the 'TEST' key. The number displayed ranges from 1 - 100 and the lower the number the better the signal strength.

If the gain figure is 50 - 100 check the surface level for foam or other materials which may float in and out of the beam and cause poor echoes.
6. Check that the ST6 eprom is seated correctly at U6 on the bottom PCB

E) The keypad fails to respond:-

1. Check for correct alignment of connection from keypad to main board.
2. Check that key press sequence is valid; refer to Programming Section.
3. Power down unit and wait 5 seconds. Power up and immediately press 'MODE'. This should result in 'PROG' being displayed. It is now advisable to reset to factory parameters; refer to Programming Section 3.

F) Analogue Output is Unstable:-

1. Connect a test meter in series with your external wiring.
Can the fault be seen on the test meter? If YES, then use Pr.34 to enter a stable value into the current loop. Suitable values range from 4 to 20.
If the output is still unstable disconnect external wiring and connect a meter across terminals 25 and 26 and repeat Pr.34 test.
If the output is now stable check wiring and meters

G) Analogue has no Output:-

1. Check programme value at Pr.30 - Value 1-6.
2. Insert a test meter in series with the output. Under Pr.34 enter a fixed output. If still no output, connect a test meter directly across terminals 25 and 26, repeat test under Pr.34. If no value is read at terminals 25 to 26 contact Hycontrol.

H) Analogue Output is less than 20 at maximum display reading:-

1. The load attached to the output may be too high. To check this disconnect all the external wiring and see if it now reads 20. The output is capable of driving 20mA into 750 Ohms.

I) Analogue Output does not correspond to application:-

1. Check that the correct options (Pr.30 to Pr.33) have been selected.
2. Check that the correct span (Pr.4) has been input, this is the value over which the analogue will be spanned unless a separate entry has been made at Pr.32 or Pr.33.

J) Reading on display and outputs stay high:-

- * This is usually caused by return echoes from close-in obstructions.
1. Check for obstructions. If the transducer is mounted on a standpipe, check for rough edges at the connection with the vessel, refer to figure 5 Page 6.

2. If there are no close-in obstructions ensure that the isolation kit is fitted on the transducer and the transducer is mounted correctly. The isolation kit should enable the transducer to move slightly, it should not be solid. (Not applicable to flanged transducers.)
3. Check the entry at Pr.5, Blanking distance, and return to 0.5m if reduced from factory setting
4. May be caused by rate of change, Pr.6 being too small.

K) Reading is lower than expected:-

1. Check that Pr.3 and Pr.4 are correct for the application
2. It can be caused when the level rises into the blanking zone. The system can then lock on to a multiple echo, and may continue tracking the multiple when the level decreases. Using check search Pr. 69 should rectify this situation, but preventing the level entering the blanking zone is the preferred solution.
3. It can also be caused by the level moving at a much faster rate than is allowed for by the defined rate of change (Pr.6) . To solve the problem the rate of change value should be increased to more closely match the real rate.

L) Reading changes in steps:-

- * This is usually caused by the rate of change value (Pr.6) being too small to keep up with the process.
1. To rectify, increase the value of Pr.6 to match the rate of change of level.

M) The display is inaccurate:-

1. The empty distance (Pr.3) of the vessel may be incorrectly set.
2. The dimensions of the vessel or flume may be incorrect, as may the values of maximum flow, volume or mass conversion.
3. The system may require temperature compensation.
4. The application may include vapours that significantly change the speed of sound. Provided these are constant over the range the speed of sound can be adjusted through Pr.70.

N) Temperature compensation error:-

1. The position of the transducer/temperature sensor is important to prevent heating by sunlight and convection currents. Also the sensor should be in a free-air vented position if possible to prevent hot-spots.
2. Check that temperature compensation is enabled at Pr.37.
3. Check the resistance of the temperature probe when disconnected against the value in Pr.39 when connected. If using a temperature compensated transducer, check this resistance value across the shield and black core when disconnected.

NOTE : The sensor compensates only for temperature variance, it is not expected to accurately measure the actual temperature.

O) The boards hums loudly:-

- * Usually vibration from the transformer.
1. Check the mounting screws for tightness.

P) Relays not switching:-

1. Check the programmed relay designations and settings at Pr.8 - Pr.22 Functions can be tested under simulation using Pr.78.
2. Test the actual relays using Pr.75 or Pr.76.
3. Check contact continuity at the terminals 4 - 18.

WARNING: It is recommended that all external controls, alarms etc. are disconnected before performing the above tests.

LINEARISATION**VESSELS OR FLUMES**

This feature allows volume conversion to be applied on irregular shaped vessels and flow measurements to be made on open channels providing that level/volume/flow relationships are known.

The system allows the entry of a volume or flow profile at up to 16 points of level to be entered into memory, that is then used to produce the required flow or volume values when in 'RUN' mode. The required profile is stored in parameter 44.

Before proceeding it is useful to write down a table of the point numbers and 'A'/'b' values to facilitate programming.

FLOW

When using the facility for flow it is enabled by Pr.45 = 4. The profile is stored as percentage of head, against percentage of flow. See example on page 48.

VOLUME

When using the facility for volume, it is enabled by Pr.40 = 8. The profile is stored as percentage of level, against percentage of the total volume. See example on page 50.

PROCEDURE

The procedure uses a 16 point curve to map the profile, but all 16 points do not have to be used.

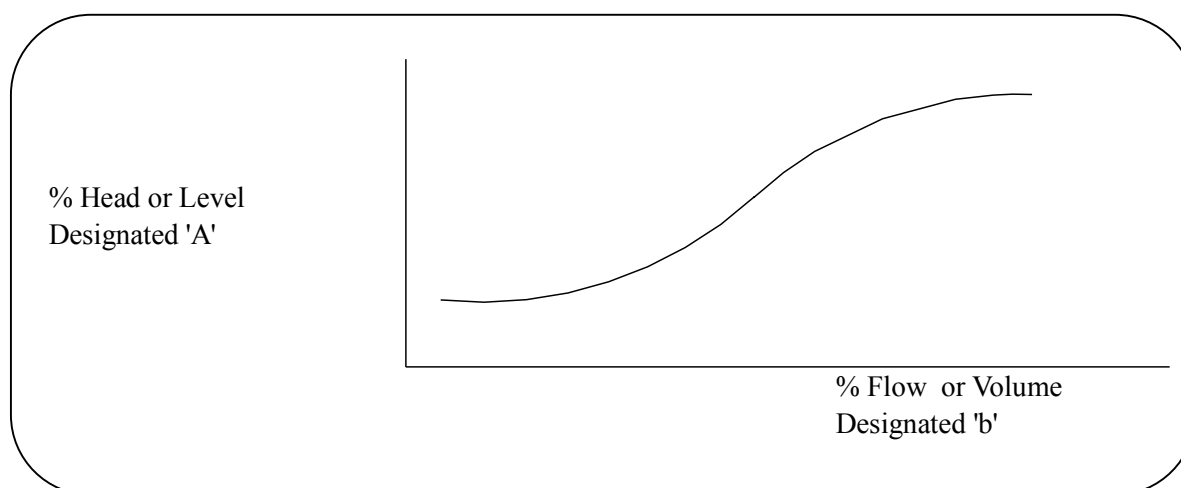

The profile data is input into Pr.44 which, when accessed, [Pr.44, 'DSP', 'ENT'] will display 'A1', which means the data pointer is at value 1 on 'A' data. The values can be displayed and changed as required.

Pr.44 - Keyboard Controls

- # - Toggles the display between data blocks 'A' and 'b'
- '▲' -} Increases and decreases the point number, when either the point number
'▼' -} or its value is displayed.
- CE - Clears the display when inputting a new value.
- DSP - Toggles the display between the block and point number and the value.
- ENT - Enters a new value.
- TEST - Exits Pr.44 and returns the operator to the normal programme.
- 0-9 - The number keys and decimal point are used to input new values. Point numbers can be changed only by using the '▲' and '▼' keys.

Pr.44 - Inputting Values

When a new value is to be entered, first display the old value and then input the new and press 'ENT', the system will display the value it has stored in memory. The values input have to be in a specific form.

1. - Head/Level - Designated 'A'
- These values must be a whole number. Decimal places will be ignored.

i.e. 11 will be accepted as 11
22.3 will be accepted as 223.

The allowable range of values is 0-250%, any unused data values must be set to 255.

PARAMETER RESET: LOADS 255 TO ALL DATA VALUES.

2. - Flow/Volume - designated 'b'
- These values are expected to contain one decimal place, therefore, it
it is not necessary to input the decimal place, but the procedure will display it.
i.e. 10 will be accepted as 1.0
100 or 10.0 will be accepted as 10.0.

The allowable range of values is 0-250%.

PARAMETER RESET: LOADS 0 TO ALL DATA VALUES.

- NOTE:**
1. As time is required to enter all the data, the standard keypad time-outs are suspended.
 2. We recommend that the required values are written in tabular form, as shown before programming commences. Then enter all Block A values, before entering all Block 'b' values.

Example: Flow – Special Flume Mapping

Use Example 5 on Page 39, but substitute a special 'U' throat flume with maximum flow 39 litres/second at 30 cm/hd.

First, create the following table from the relationship of head and flow which must be given for the special flume.

Point	Head (cm)	% Head	'A' Value	Flow litres/sec	% Flow	'b' Value
1	0.0	0.0	0	0.0	0.0	0
2	2.5	8.3	8	0.4	1.1	11
3	5.0	16.7	17	1.7	4.4	44
4	7.5	25.0	25	3.7	9.5	95
5	10.0	33.3	33	6.3	16.2	162
6	15.0	50.0	50	12.7	32.5	325
7	20.0	66.6	67	20.3	52.0	520
8	25.0	83.2	83	29.3	75.0	750
9	30.0	100.0	100	39.0	100.0	1,000
10	Not used	Not used	255	Not used	Not used	.0
11	Not used	Not used	255	Not used	Not used	.0
12	Not used	Not used	255	Not used	Not used	.0
13	Not used	Not used	255	Not used	Not used	.0
14	Not used	Not used	255	Not used	Not used	.0
15	Not used	Not used	255	Not used	Not used	.0
16	Not used	Not used	255	Not used	Not used	.0

- NOTE:**
1. Points 10 to 16 not used - leave at factory default value.
 2. 'A' values must be whole numbers, no decimals allowed.
 3. 'b' values must be entered as the tabulated value, the decimal will be automatically allocated.

Now continue programming the instrument as follows:

Programme the instrument exactly as Example 5 on Page 39, except:

- Change Pr.45 from 2 to 4, which denotes "Special Flow Device".
- Go to Pr.44 and proceed as follows:
- Press Pr.44 to display Pr.44:
- Press 'DSP' to show '≡≡≡'
- Press 'ENT' to show 'A1'
- Press 'DSP' to show value of 'A1' (default = 255)
Key in the value '0' from Table 1 and press 'ENT'
- Press 'DSP' to show 'A1' again
- Press '▲' to show 'A2'
- Press 'DSP' to show value of 'A2' (default = 255)
Key in the value '8' from Table 1 and press 'ENT'
Continue for all points which you need to use (up to 'A16')
Any points not used must be left at the default of 255
- Press 'DSP' to display the last 'A' number used, then
- Press '▼' several times to return to 'A1'
- Press # to show 'b1'
- Press 'DSP' to show value of 'b1' (default = .0)
Key in the value '0' from Table 1 and press 'ENT'
- Press 'DSP' to show 'b1' again
- Press '▲' to show 'b2'
- Press 'DSP' to show value of 'b2' (default = .0)
Key in the value '11' from Table 1 (accepted as 1.1)
Continue for all points which you need to use (up to 16)
Any points not used must be left at the default of .0
- Press 'TEST' then 'DSP' to show Pr.44

Leave the linearisation part of the programme by displaying any other parameter, or go into 'RUN' mode.

EXAMPLE - Vessel Mapping**Required Values**

Point Number	'A' % Head or Level	'b' % of flow or volume
1	0	0.0
2	10	0.0
3	20	7.2
4	30	16.1
5	40	27.3
6	50	37.5
7	60	48.5
8	70	59.5
9	80	70.5
10	90	80.0
11	100	89.5
12	110	100.0
13	255	
14	255	
15	255	
16	255	

SPECIFICATION**Transceiver**

Enclosure	: IP65 and NEMA 4X polycarbonate, hinged lid.
Dimensions	: 240H X 160W X 90D (mm).
Weight	: 1.75Kg
Power Supply	: 110/230Vac \pm 10% selected automatically. 50/60Hz, 12VA, 24Vdc + 25% - 10%, 9W. Separate terminals.
Fuse Rating	: F5 T160mA for ac supply F6 T315mA for 24Vdc supply F1 & F2 T80mA.
Range	: Up to 10 metres.
Accuracy of Change in Level	: \pm 0.25% of measured distance from the transducer at constant temperature of 20 deg C,
Ambient Temperature	: -40 deg C to + 70 deg C.
Resolution	: 2mm or 0.1% of range, whichever is the greater.
Analogue Output	: 4-20mA into 750 Ohms. 16 bit. Short circuit protected and opto-isolated on ac powered units. Not opto-isolated on 24Vdc units. Maximum allowable degradation of signal 2% under extremes of transient and constant conducted immunity tests to EN50082.
Relay Outputs	: 5 multi-function SPDT relays rated 8A/250Vac/30Vdc resistive, with gold contacts.
Indication	: Integral, 4 digit LCD, 12mm high characters. 5 red LED's to indicate relay status.
Interface	: 5 X 4 integral keypad with security code.
Failsafe	: High, Low, Hold
Damping	: Fully adjustable
Blanking	: Fully adjustable

Transducer

Type	: RZV15	RZT15	RZV15T
Temperature Compensation	: Uncompensated	Compensated	Uncompensated
Frequency (in KHz)	: 41.5	41.5	41.5
Beam Angle at 3dB	: 10 degrees	10 degrees	10 degrees
Body Material	: Xenoy	Xenoy	Xenoy
Face Material	: Urethane	Urethane	Teflon
Process Temperature *	: -40 to + 90 deg C	-40 to + 90 deg C	-40 to +90 deg C
Protection	: IP68	IP68	IP68
Weight (Kg)	: 2	2	2

NOTE: * CE approved - EMC tested in accordance with EN50081 & EN50082
Parts 1 & 2
Low voltage directive, EN61010

Installation Instructions for ATEX Transducer in Hazardous Area

For transceiver installation and programming refer to the appropriate transceiver manual:

PPSC	MINIFLEX	MICROFLEX
TWINFLEX	LIQUIFLEX	MULTIFLEX
REFLEX	CS01	

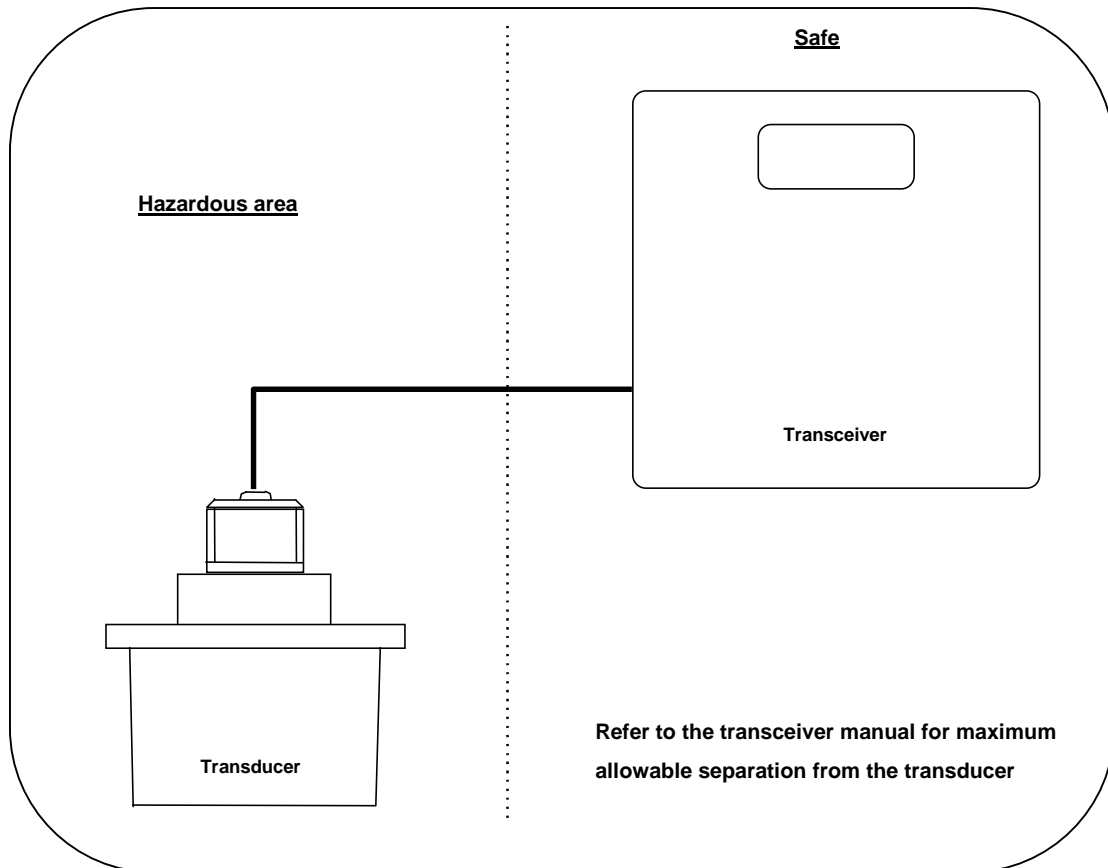

Installation must be in accordance with the applicable codes of practice and harmonised standards for EEx m (encapsulated) equipment.

The transducer must be driven only by one of the above listed transceivers.

The transceiver must always be installed in a safe area.

Specification

Transducer Type	RXV15	RXT15	RZV15	RZT15
Temperature compensated	No	Yes	No	Yes
Frequency (KHz)	41.5	41.5	41.5	41.5
Body material	Xenoy	Xenoy	Xenoy	Xenoy
Face material (*)	Urethane	Urethane	Urethane	Urethane
Temperature (deg C)	-20 to +55	-20 to +55	-20 to +55	-20 to +55
Protection	IP68	IP68	IP68	IP68
Weight (Kg)	2.0	2.0	1.5	1.5

* Alternative facing materials: Polypropylene or PTFE

Alternative flanged construction: 3" or 4" / DN80 or DN100

Typical marking

Manufacturer: Hycontrol Limited

Group / category:  0492  II 2 G/D

CE certification: ISSeP 03ATEX021X

Type: xxxxxxxx

Type of protection: EEx m II T6

Tamb: -20 to +55 deg C

Degree of protection: IP68

Maximum input: 6W

S/No: xxxxxxxx

Mfg. Year: xxxx

LIQUIFLEX PLC BS3680 Flow Devices

To ensure compliance with BS3680 the following additional parameters are available:-
Refer to Page 26 for full programming and standard parameter details.

- Pr.45 Enter 15 - Rectangular Flume
16 - Rectangular Thin-Plate Weirs
17 - V-notch Thin-Plate Weirs

- Pr.80 Enter 0 - Absolute
Enter also max. head @ Pr.04 (span)
The unit will then calculate max. flow and store it @ Pr.46 when you have completed programming and entered the unit into RUN mode.
The calculated flow is always in litres/sec (Pr.47 defaults to 1, other values are ignored)
If the flow exceeds 9999, Pr.46 will display FULL; you must then use the ratiometric method as detailed below, adjusting flow units as necessary e.g. 16000 l/s could become 16 m³/s or 960 m³/min.

- 1 - Ratiometric
Enter max. head @ Pr.04
Enter max. flow @ Pr.46 (Any unit, m³ / litres / gallons etc. but 9999 or less)
Enter time base @ Pr.47 (Choose secs / mins / hours / days)

For Rectangular Flume (Pr.45 = 15)

- Pr.81 Enter throat width } In units selected @ Pr.02
Pr.82 Enter channel width }
Pr.83 Enter throat length }
Pr.84 Height of hump (0 if none)}

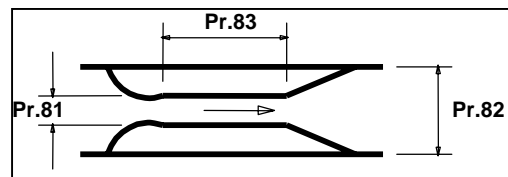

For Rectangular Weir (Pr.45 = 16)

- Pr.85 Enter crest width } In units selected @ Pr.02
Pr.86 Enter channel width }
Pr.87 Enter crest height }

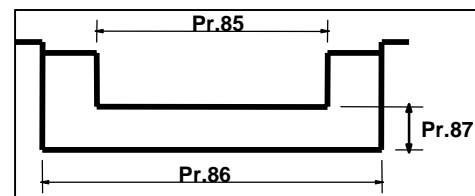

For V-Notch Weir (Pr.45 = 17)

- Pr.88 Enter full angle in degrees e.g. 120 / 90 / 53.1 / 28.1
Pr.89 Enter channel width } In units selected @ Pr.02
Pr.90 Enter vertex height }

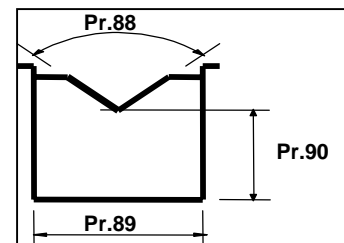

Note that all other standard flow parameters are available i.e.

- Pr.48 Totaliser display conversion
Pr.49 Control external counter
Pr.50 Penstock control
Pr.71 Correction value
Pr.98 Clear OCM totaliser

PARAMETER SETTINGS

Pr	Description	Factory Default	User	Eng	Pr	Description	Factory Default	User	Eng
Basic Set-up					Open Channel Flow				
1	Application	2			45	Flow Exponent	1		
2	Units	2			46	Max. Flow Rate	0		
3	Empty Distance	10			47	Time Base for Flow	1		
4	Operational Span	10			48	Totalise Display Conv.	0		
5	Blanking Distance	0.5			49	Contr. for Ext. Sampler	0		
6	Rate of Change	1			50	Penstock Control	1		
Relays					Pump Controls				
8	Relay 1	0			51	Pump Sequence	1		
9	Relay 1 Set	0			52	Duty Standby	1		
10	Relay 1 Reset	0			53	Pump Exerciser	1		
11	Relay 2	0			54	Pump Tolerance	1		
12	Relay 2 Set	0			55	Pump Maintenance	0		
13	Relay 2 Reset	0			56	Run-on-Interval	0		
14	Relay 3	0			57	Run-on-Time	0		
15	Relay 3 Set	0			Echo Detection				
16	Relay 3 Reset	0			68	Echo Selection	2		
17	Relay 4	0			69	Check Search	1		
18	Relay 4 Set	0			70	Echo Velocity	344.1		
19	Relay 4 Reset	0			Miscellaneous				
20	Relay 5	0			71	Correction Value	0		
21	Relay 5 Set	0			72	Parameter Display	0		
22	Relay 5 Reset	0			73	Software Rev. No	LA *		
Failsafe					74	Reset Counter	0		
23	Failsafe R1	3			Test Parameters				
24	Failsafe R2	3			75	Digital Output Set	0		
25	Failsafe R3	3			76	Hardware Test	'=====		
26	Failsafe R4	3			77	Transmitter Test	'=====		
27	Failsafe R5	3			78	Simulation	'=====		
28	Failsafe Analogue	3			Flow BS3680				
29	Failsafe Time Delay	120			80	Calculation method	0		
Analogue					81	Flume throat width	0		
30	Analogue Output	1			82	Flume channel width	0		
31	Analogue Options	1			83	Flume throat length	0		
32	Analogue Datum	0			84	Flume hump height	0		
33	Analogue Span	100			85	Weir crest width	0		
34	Analogue Test	0			86	Weir channel width	0		
Temperature					87	Weir crest height	0		
37	Probe Enable	1			88	V-notch angle	0		
38	Temp. Compensation	20			89	V-notch channel width	0		
39	Probe Test	0.00			90	V-notch vertex height	0		
Volume Conversion					Number Store				
40	Vessel Shape	0			95	Serial Number Store	Ser.No.		
41	Dimension H	0			96	Security Code Store	15.02		
42	Dimension L	0			Reset				
43	Display Conversion	1			97	Relay Hrs/Starts Reset	'=====		
44	Volume Linearisation				98	OCM Totaliser Reset	'=====		
					99	Full System Reset	'=====		

PARSHALL FLUMES

The OCM flow exponent (Pr.45) has been expanded to include 10 Parshall flume profiles. The data for the selected flume is loaded into the flume mapping system (Pr.44) from tables held in memory.

	<u>Size</u>	<u>Exponent</u>	
Pr.45 =	5 : 1,2,3,24	inches	1.550
	6 : 6	inches	1.580
	7 : 9	inches	1.530
	8 : 12	inches	1.522
	9 : 18	inches	1.538
	10 : 36	inches	1.566
	11 : 48	inches	1.578
	12 : 72	inches	1.595
	13 : 96	inches	1.606
	14 : 10,12,15,20, 25,30,40,50	feet	1.600

Maximum head is entered in Pr.4 and the associated maximum flow in Pr.46. If one of the values is known, the other can be found in the flume tables or by calculation from :

$$Q = KH^n \text{ GPM,}$$

where H = Inches, Q = US GPM and K = Constant for flume size
(for imperial gallon multiply K factor by 0.8).

Flume Size - Inches	K Factor for US GPM	Flume Size - Feet	K Factor for US GPM
1	3.22	10	331.60
2	6.45	12	393.70
3	9.46	15	486.90
6	18.20	20	642.10
9	30.80	30	797.40
12	40.90	40	1263.00
18	58.90	50	1574.00
24	76.30		
36	110.00		
48	142.00		
72	204.70		
96	256.60		



Larchwood House, Orchard Street, Redditch,
Worcestershire, B98 7DP.
Tel: 01527 406800
Fax: 01527 406810
Web: www.hycontrol.com
Email: sales@hycontrol.com

LWIM-3