



Vibrating Level Switch DP660

Instruction Manual

IMPORTANT:

For safety reasons and correct function of these switches it is strongly recommended to carefully read this instruction manual before installation!

Application

The DP660 is a vibration type level switch that detects the minimum or maximum level in bins, silos and hoppers. Typical applications are for granular and pellet products.

IMPORTANT:

The switches cannot be used for detecting sticky materials that tend to build a deposit on them. The DP660 is not recommended for detecting fine powders.

General Notes:

- Installation and maintenance must be performed by qualified technical personnel only.
- The DP660 must be used only in the manner outlined in this instruction manual.
- The vibrating level switches DP660 are sensitive sensors which need to be handled with care. Never expose them to mechanical loads and temperatures higher than indicated in the technical data or make any changes to them.

Function

The signal from the electronic circuit of the DP660 excites the probe to vibrate at its resonance frequency of approximately 460Hz. When material covers the probe the vibration stops. This is sensed by the electronic circuitry which forces its output to switch. When the probe is uncovered the vibration restarts and the output signal switches back.

Technical Data

Probe:	stainless steel 1.4301 / AISI 304 resonance frequency approx. 460 Hz
Process Connection:	thread R1 (1" BSPT) or 1" NPT
Power Supply:	24V AC/DC
Power consumption:	<1 VA
Output:	Relay: 1 volt-free change-over contact (SPST) max. switching voltage 50V max. switching current 1A max. switching power 15 W <i>or</i> 24V output, max.625mA
Time Delay:	1 second from stop of vibration 2 to 5 seconds for start of vibration
Indication:	output signal: red LED on connector

min. density of material to be monitored: depending on material characteristics 50 g / litre

max. vertical and horizontal load on the end of the blade: 80 N

max. pressure inside bin: 10 bar

protection: IP65

temperatures: ambient temperature: -20°C ... + 60°C
process temperature: -20°C ... + 70°C

CE-Conformity

The vibration type level switch DP660 meets the requirements of the following regulations:

- EC-EMC-directive 89 / 336 / EWG
- EC-Low Voltage Directive 73 / 23 / EWG

The following standards apply:

EN61010T1
EN61326-1
EN61326/A1

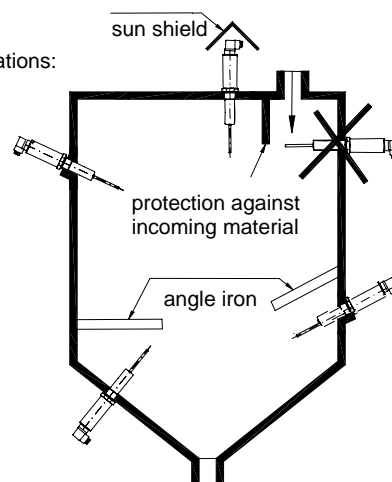

Mounting

The following has to be considered when mounting the DP660:

- The switching point of the DP660 depends on the density of the material: for heavy materials only a few millimetres of the vibrating rod have to be covered for damping the vibration. For light materials the material must cover the vibrating rod completely in order to damp its vibration.
- The DP660 must not be mounted in or near the path of incoming material. The falling material could damage the probe.
- In order to keep the ambient temperature of the PCB below 60°C the switch should be protected from direct sunlight by installing a sun shield.

Side mounting or vertical mounting

- The DP660 can be mounted in the container either from the side or vertical from top or bottom.
- For side mounting it is recommended to screw the DP660 into the bin wall with the vibrating rod pointing slightly downwards (approx. 20°) so that material can more easily flow and does not rest on the vibrating rod.
- The DP660 must not be mounted in or near the path of incoming material. If this cannot be avoided a protection shield, for example an angle steel with side length approx. 50mm, must be installed approx. 150mm over the probe. A protection shield is necessary for low level detection in order to protect the probe against falling material.
- The DP660 is installed by screwing the mounting thread into the bin wall with an open-end wrench.
- A suitable sealing, (like Teflon tape), should be applied to the thread.

Orientation of the cable gland:

- The cable gland must always point downwards to prevent moisture seeping inside the connector. The connector can get turned in 90° steps to keep the cable gland pointed downwards. Push the connector block out of the plug, for wiring, and re-position it for the required orientation.

Wiring

Safety Guidelines:

- Wiring of these switches must only be performed by qualified technical personnel.
- Before you start wiring make sure that power supply on all wires has been switched off.
- In accordance with EN 61010-1 a main switch must be installed nearby with which power supply **and** output signal can be switched off. This switch must be marked as main switch of the unit.

The cables for power supply and output must be connected to the terminals according to the following sketch:
(cable cross-section max. 1,5mm²)

Relay-Output (SPST)

- 1 = Relay contact 1
- 2 = Relay contact 2
- 3 = Power supply 24V DC or 24V AC (+/- 10%)
- 4 = Ground

24V-Output

- 1 = not connected
- 2 = 24V output
- 3 = Power supply 24V DC or 24V AC (+/- 10%)
- 4 = Ground

The relay output can be used as 24V output by simply connecting Pin 3 to Pin 1, inside the plug. The 24V output will then be on pin 2 when the switch is energised.

Adjustment

Failsafe High (FSH) / Failsafe Low (FSL):

Switching Logic: see following sketch.

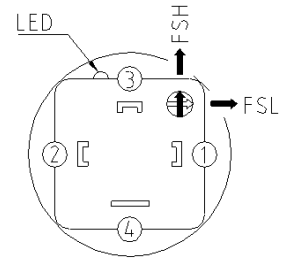

Failsafe high: turn switch to position FSH:
 high level alarm:
 the relay is de-energized (red LED off), when the blade is covered by material or power has failed.

Failsafe low: turn switch to position FSL:
 low level alarm:
 the relay is de-energized (red LED off), when the blade is free, (not covered by material), or power has failed.

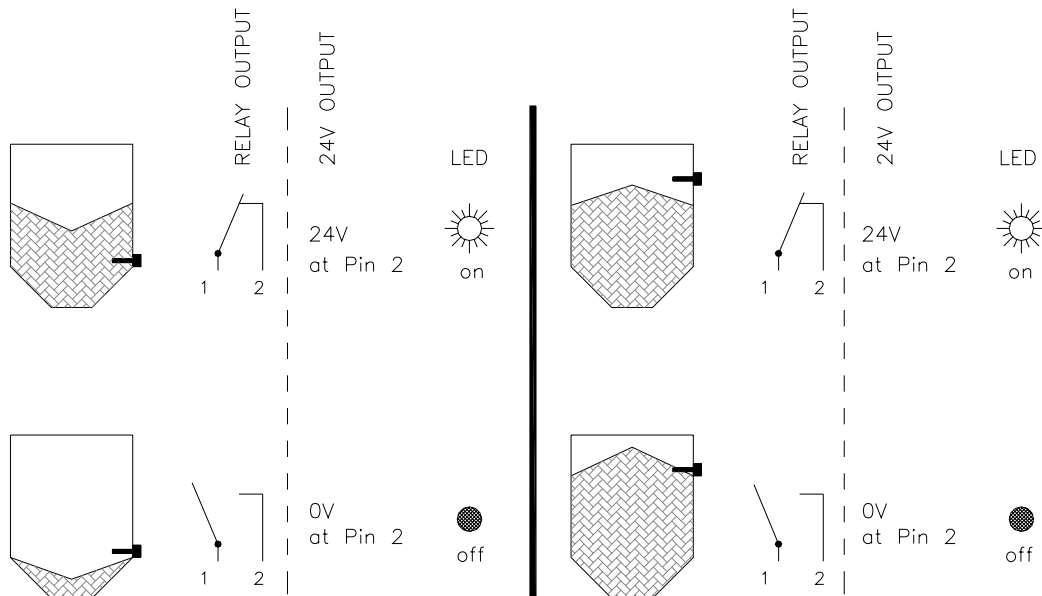

Low Level Alarm, Fail Safe Low

High Level Alarm, Fail Safe High

Maintenance

The vibrating type level switches DP660 require no maintenance.
For applications with materials that are slightly sticky we recommend cleaning the vibrating rod after a certain period of time.
If the switches are exposed to a corrosive atmosphere they must be inspected periodically to avoid corrosion, in order to ensure the continued protection of the switch.

Dimensions

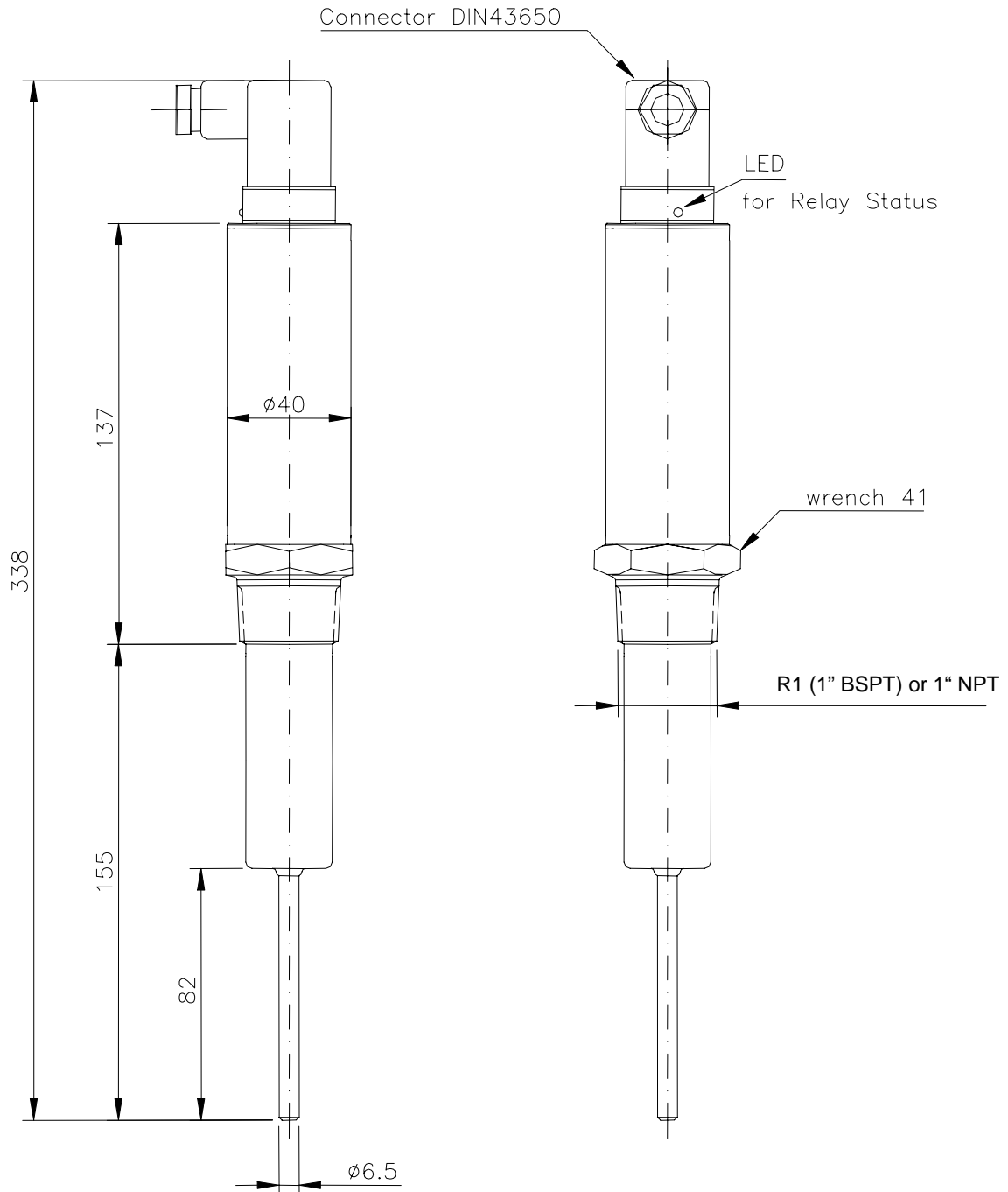

HYCONTROL LEVEL TECHNOLOGIES

Level product range includes :-

- (1) TDR Radar for solids
- (2) Ultrasonic, 'through air'
- (3) Continuous 'servo' level indicator
- (4) Capacitance level switch
- (5) Vibrating probe level switch
- (6) Rotating paddle level switch
- (7) By-pass level indicator with radar
- (8) TDR Radar for liquids
- (9) 2 wire Ultrasonic transmitter
- (10) FMCW 'Wavestick' Radar
- (11) Magnetic Float switches
- (12) FMCW 'Horn' Radar
- (13) Capacitance level switch
- (14) Side mounting 316 SS float switch
- (15) Vibrating fork level switch
- (16) Ultrasonics 'through wall'
- (17) Mini magnetic float level switch
- (18) RF Admittance level switch

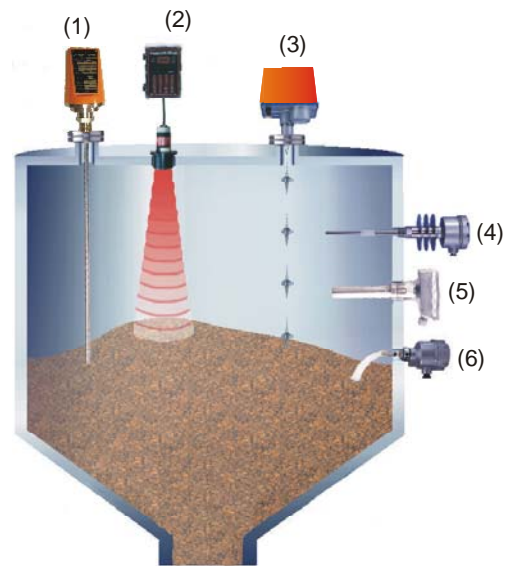

SOLIDS

IF YOU ARE UNSURE WHICH TECHNOLOGY TO USE FOR YOUR APPLICATION PLEASE CONSULT HYCONTROL INSTRUMENT ENGINEERS FOR APPLICATION ADVICE OR A FREE SITE LEVEL SURVEY.

HYCONTROL LTD
Larchwood House
Orchard Street
Redditch
Worcestershire
England
B98 7DP

Tel : 01527 406800
Fax : 01527 406810

Email : sales@hycontrol.com
Website : www.hycontrol.com

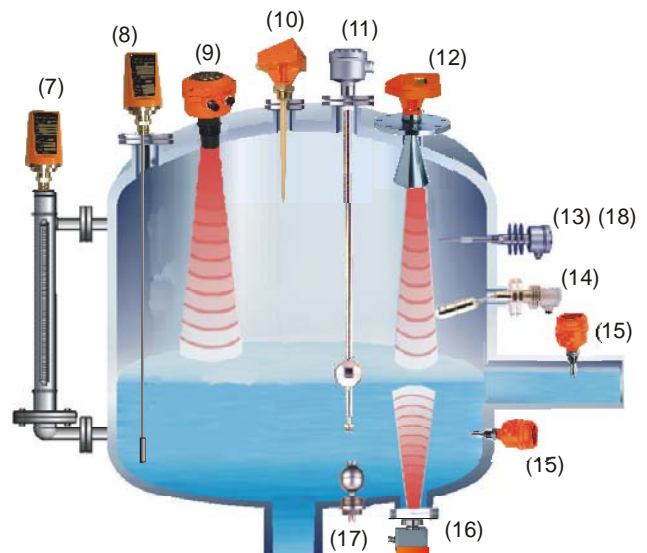

LIQUIDS