



CAPACITIVE LEVEL SWITCHES

HYCONTROL CAPACITIVE LEVEL SWITCH RANGE

Hycontrol ME capacitive level switches provide simple, accurate and reliable level control for a wide range of applications. They are suitable for use on liquids, solids, slurries, pastes, granules, powders and pellets in high temperature, high pressure and corrosive environments.

Unlike some other capacitive switches, this unit works independently of the tank walls using an integral grounding sleeve without the need for a reference probe, which enables it to be used in concrete, plastic or other non metallic tanks.

This technology also provides an ideal solution for interface detection applications such as oil on water and liquid detection underneath a layer of foam.

CAPACITIVE SWITCH FEATURES

- Easy installation through a 1" BSP process fitting
- High corrosion and chemical resistance as standard options
- Universal design can be used for high or low level detection
- Failsafe options high and low selectable
- Multiple versions with rod and cable to simplify mounting options
- High temperature versions up to 800 °C
- Low maintenance technology with no moving parts
- Hazardous area certified versions ATEX approved
- Adjustable sensitivity for a wide range of products
- Adjustable time delay to stop spurious signals from surface ripple
- Anti-static probes for plastic pellet applications with high static probability
- Remote electronics option for high vibration applications
- Interface level detection for difficult applications

CONSTRUCTION

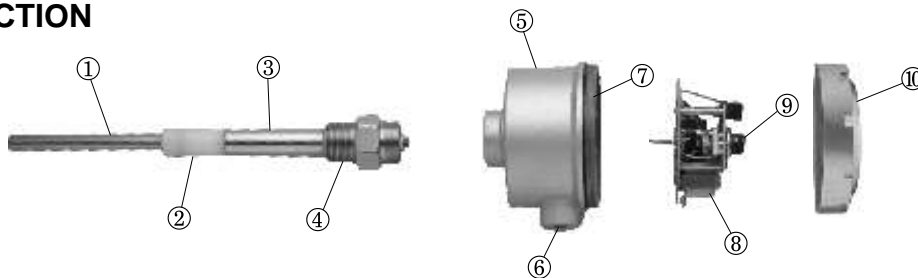

1. Probe : 304SS or 316SS
2. Insulation : UPE or PTFE
3. Grounding Sleeve : 304SS or 316SS
4. Connection : 1" BSP standard
5. Housing : Aluminum IP65 epoxy coated

6. Conduit entry : 2 x M20
7. Housing O-Ring : NBR
8. PC board : A, B, C, D Type
9. Sensitivity adjustment : 10pF, 20pF, 40pF
Failsafe : Hi / Low Selectable
10. Cover : Aluminum epoxy coated

STANDARD GENERAL PURPOSE VERSIONS

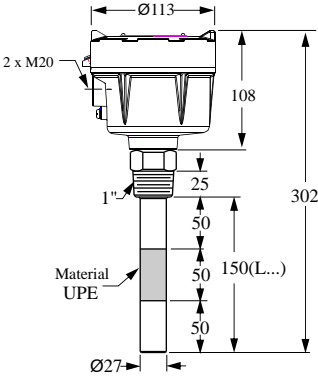
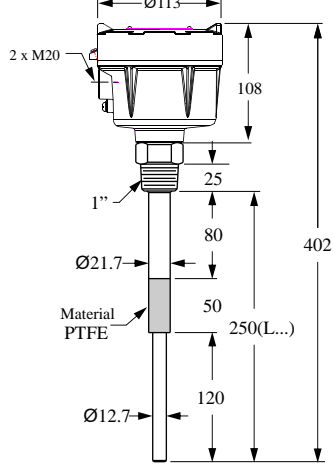
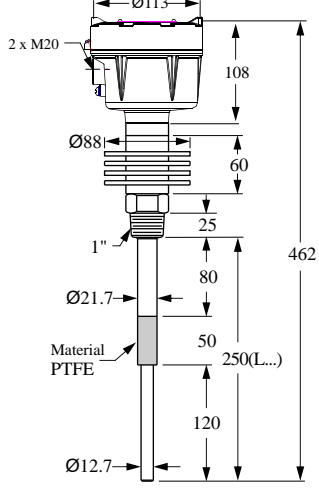
| | | | |
|----------------------------|-----------------------------------------------------------------------------------|------------------------------------------------------------------------------------|-------------------------------------------------------------------------------------|
| Dimension |  |  |  |
| Model | ME10 A/B/C [STANDARD TYPE] | ME11 A/B/C [STANDARD TYPE] | ME20 A/B/C [HI-TEMP. TYPE] |
| Operating Temp. | -20°C~80°C | -20°C~80°C | -20°C~200°C |
| Probe Material | 304SS | 304SS | 304SS |
| Insulation Material | UPE | UPE | PTFE |
| Connection | 1"BSP | 1"BSP | 1"BSP |
| Sensitivity Range | 10pF, 20pF, 40pF | 10pF, 20pF, 40pF | 10pF, 20pF, 40pF |
| Weight | Approx. 1.9kg | Approx. 1.9kg | Approx. 2.4kg |
| Enclosure details | Aluminum IP65 | | |
| Supply Voltage | 110/220VAC ±10% or 24VDC | | |
| Delay Time | 0~6 seconds | | |
| Power Consumption | 2W | | |
| Contact Rating | 5A/240VAC or 5A/30VDC, SPDT or NPN 100mA | | |

HIGH TEMPERATURE AND CORROSION RESISTANT VERSIONS

| | | | |
|----------------------------|------------------------------------------|----------------------------------------------|--------------------------------------------------------------------|
| Dimension | | | |
| Model | ME28 A/B/C [HI-TEMP.] | ME30 A/B/C [CORROSION-PROOF] | ME32 A/B/C [CORROSION-PROOF] |
| Operating Temp. | -20°C~800°C | -20°C~80°C | -20°C~120°C |
| Probe Material | 304 SS | 304 SS | Wetted part: PVDF coating |
| Insulation Material | CERAMIC | Wetted part: UPE coating | UPE |
| Connection | 2"x5kg/cm ² JIS Flange (SS) | 1-1/2"x10kg/cm ² JIS Flange (UPE) | 1-1/2"x10kg/cm ² JIS Flange (SS) with PVDF Washer (5mm) |
| Sensitivity Range | 10pF, 20pF | 10pF | 10pF, 20pF |
| Weight | Approx. 6.5kg | Approx. 2kg | Depends on the length |
| Enclosure details | Aluminum IP65 | | |
| Supply Voltage | 110/220VAC±10% or 24VDC | | |
| Delay Time | 0~6 seconds | | |
| Power Consumption | 2W | | |
| Contact Rating | 5A/240VAC or 5A/30VDC, SPDT or NPN 100mA | | |

REMOTE AND CABLE VERSIONS

| | | | |
|-----------------------------------|----------------------------------------------------|--------------------------------------------------|---------------------------------------------------|
| <p>Dimension</p> | | | |
| <p>Model</p> | <p>ME40 A/B/C [REMOTE PROBE TYPE]</p> | <p>ME50 A/B/C [WIRE-PROBE TYPE]</p> | <p>ME60 A/B/C [PLATE TYPE]</p> |
| <p>Operating Temp.</p> | <p>-20°~100°C</p> | <p>-20°C~80°C</p> | <p>-20°C~80°C</p> |
| <p>Probe Material</p> | <p>304 SS</p> | <p>304 SS cable</p> | <p>304 SS</p> |
| <p>Insulation Material</p> | <p>UPE</p> | <p>UPE</p> | <p>UPE</p> |
| <p>Connection</p> | <p>1"BSP (SS)</p> | <p>1"BSP (SS)</p> | <p>2-1/2"x 5kg/cm² JIS Flange (SS)</p> |
| <p>Sensitivity Range</p> | <p>10pF</p> | <p>10pF, 20pF, 40pF</p> | <p>10pF, 20pF, 40pF</p> |
| <p>Weight</p> | <p>Approx. 3kg</p> | <p>Approx. 4.1kg</p> | <p>Approx. 3.2kg</p> |
| <p>Enclosure details</p> | <p>Aluminum IP65</p> | | |
| <p>Supply Voltage</p> | <p>110/220VAC±10% or 24VDC</p> | | |
| <p>Delay Time</p> | <p>0~6 seconds</p> | | |
| <p>Power Consumption</p> | <p>2W</p> | | |
| <p>Contact Rating</p> | <p>5A/240VAC or 5A/30VDC, SPDT or NPN 100mA</p> | | |

ANTI-STATIC AND TEFLON PROBE VERSIONS

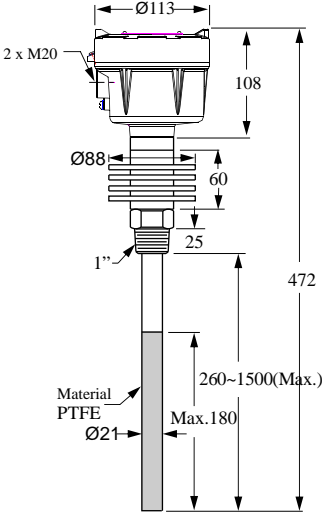
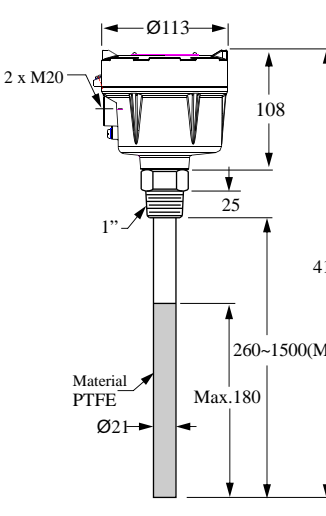
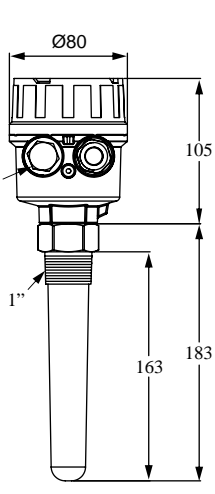
| Dimension |  |  |  |
|---------------------|-----------------------------------------------------------------------------------|------------------------------------------------------------------------------------|-------------------------------------------------------------------------------------|
| Model | ME80 A/B/C [ANTI-STATIC TYPE] | ME81 A/B/C [ANTI-STATIC TYPE] HI-TEMP. | ME90 [MULTI-FUNCTION TYPE] |
| Operating Temp. | -20°C~80°C | -20°C~200°C | -20°C~80°C |
| Probe Material | UPE coating | PTFE coating | PTFE, PP (ME90 R/N) (ME90R-M/ ME90N-M) |
| Insulation Material | UPE | PTFE | ————— |
| Connection | 1"BSP (SS) | 1"BSP (SS) | 1"BSP |
| Sensitivity Range | 10pF, 20pF | 10pF, 20pF | 10pF |
| Weight | Approx. 2kg | Approx. 2.5kg | Approx. 0.8kg |
| Enclosure details | Aluminum IP65 | | Aluminum IP65 |
| Supply Voltage | 110/220VAC±10% or 24VDC | | 20~250Vac/dc, 50/60 Hz |
| Delay Time | 0~6 seconds | | 0~6 sec |
| Power Consumption | 2W | | 2W |
| Contact Rating | 5A/240VAC or 5A/30VDC, SPDT or NPN 100mA | | R: Relay SPDT, 5A/250Vac/30Vdc N: MOSFET 400mA/ 60Vac/dc |

ADJUSTMENT

COARSE CALIBRATION

With the probe in contact with the material being detected, set the *SENSITIVITY ADJ* pointer to position H and then using a blade screwdriver set the *COARSE* adjustment until the *INDICATOR* lamp is on. Rotating the *COARSE* adjustment clockwise and counter-clockwise will turn the *INDICATOR* lamp on and off. Ensure the lamp is on before moving on to adjusting the sensitivity.

SENSITIVITY ADJUSTMENT

After setting the *COARSE* calibration the *INDICATOR* lamp will switch on when probe is touching the material and off when in free air.

Make sure the probe is in contact with the material and then turn the *SENSITIVITY ADJ* knob clockwise until the *INDICATOR* lamp turns off. Set the *SENSITIVITY ADJ* pointer half way between H and the point that the *INDICATOR* lamp switches off.

Calibration is now complete.

DELAY FUNCTION SETTING

This feature is used to stop any spurious signals to the switch from surface ripple or agitation of the product. It also protects the relay from premature wear by eliminating contact chatter by adding a small time delay from when product contacts the probe.

The factory setting is zero seconds with the *DELAY* screw fully counter clockwise. Turning the screw in a clockwise direction introduces a delay between the *INDICATOR* lamp coming on and the relay changing its state.

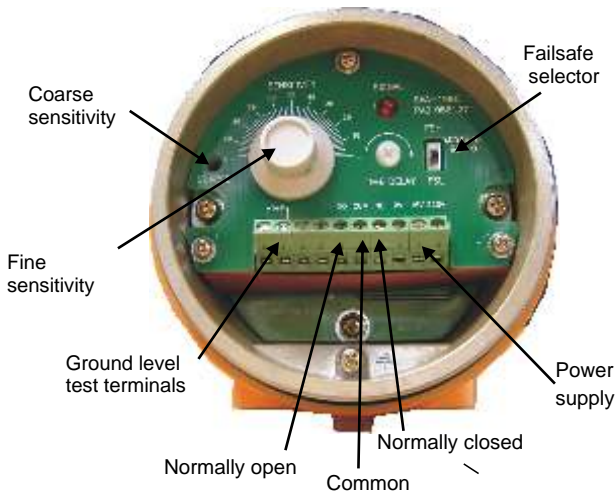

ME10,20,30,50,60,70,80 A/B/C/D

CALIBRATION STEP OF SENSIVITY

SA190 If LED indicator is not on after the above calibration, please perform the following procedures:

1. Set sensitivity to be OFF (Figure 2).
2. Turn COARSE until red SIGNAL LED just turns on.
3. Set sensitivity ON (90%) in dip switch 1 (Figure 3). LED indicator will turn off and no signal output. Then set sensitivity all in OFF position. LED indicator will turn on again to complete the calibration procedure.

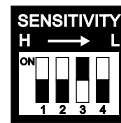

Figure 1

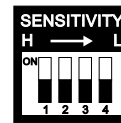

Figure 2

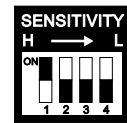

Figure 3

Sensitivity Adjustment

| Sensitivity Adjustment | 4 Step DIP Switch | | | | Adjust Mode |
|------------------------|-------------------|-----|-----|-----|------------------------------------|
| | (1) | (2) | (3) | (4) | |
| 1P | ● | | | | Switch (1) ON / Switch (2+3+4) OFF |
| 2P | | ● | | | Switch (2) ON / Switch (1+3+4) OFF |
| 3P | | | ● | | Switch (3) ON / Switch (1+2+4) OFF |
| 4P | | | | ● | Switch (4) ON / Switch (1+2+3) OFF |
| 5P | | ● | ● | | Switch (2+3) ON / Switch (1+4) OFF |
| 6P | ● | ● | ● | | Switch (1+2+3) ON / Switch (4) OFF |
| 7P | | | ● | ● | Switch (3+4) ON / Switch (1+2) OFF |
| 8P | ● | | ● | ● | Switch (1+3+4) ON / Switch (2) OFF |
| 9P | | ● | ● | ● | Switch (2+3+4) ON / Switch (1) OFF |
| 10P | ● | ● | ● | ● | Switch (1+2+3+4) ON |

Fail Safe Selection

FSH Mode:

Fail-Safe High means that the relay will be energized when the sensing probe is uncovered by the medium (SIGNAL LED is on) and will de-energize when the probe is covered (SIGNAL LED is off). In this mode, a power failure will cause the relay to de-energize like the probe is covered.

FSL Mode:

Fail-Safe Low means that the relay will be de-energized when the probe is uncovered (SIGNAL LED is off) and will energize when the probe is covered (SIGNAL LED is on). In this mode, a power failure will cause the relay to de-energize like the probe is uncovered.

Time Delay

1. Time delay allows the level switch to change state with range from 0~6 seconds when condition changes from a covered to an uncovered condition and from an uncovered to a covered condition. If delay mode is not set, level switch will change state immediately when probe is covered by the medium.
2. Turn time delay knob clockwise to increase delay time and counter-clockwise to decrease delay time.

INSTALLATION GUIDE

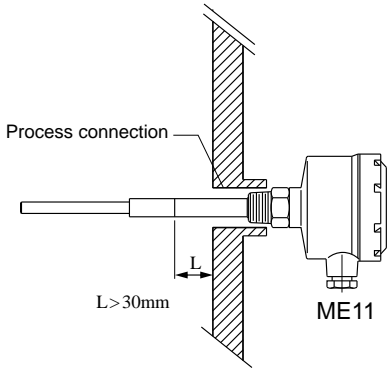

The grounding sleeve must be mounted to protrude at least 30mm from the vessel wall.

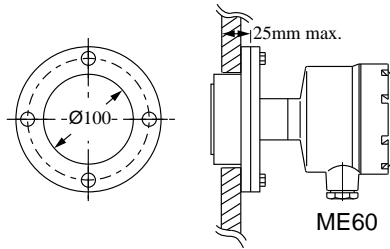

For the ME60 type to be mounted properly the vessel walls should not exceed 25mm thickness.

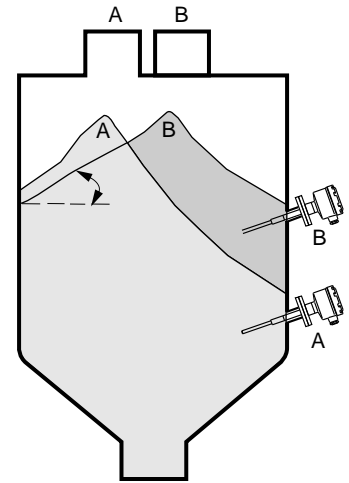

To prevent false readings on solids applications it is best to make sure the material flows symmetrically. If the inlet is not located in the centre portion of the tank roof, check the flow pattern (a angle) of your material and place the probe in the appropriate location.

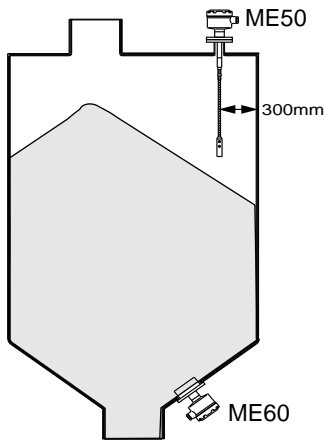

If the probe is mounted on the top, make sure the length of probe is enough to touch the highest level of raw material. The ME50 type must have at least 300mm from the silo wall. The ME60 type is usually located at the lower position.

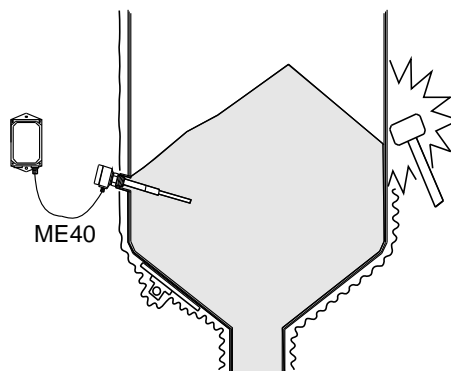

For Non-Stationary or material that will be vibrated a separate control unit such as the ME40 type is recommended.

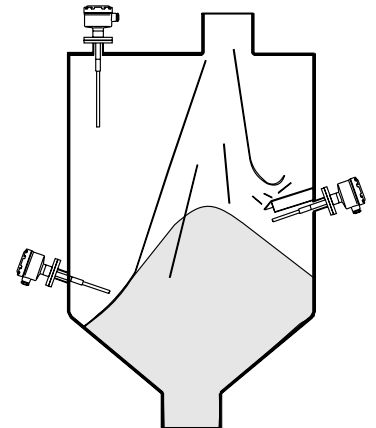

Where possible install the probe away from the inlet to reduce the risk of inflowing material damaging the probe. If the probe is near an inlet, we recommend placing a protective cover 200mm above the probe. The cover should be parallel to the probe and the same length.

INSTALLATION GUIDE

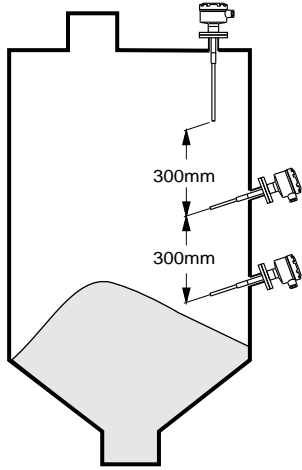

If multiple probes are mounted in the same vessel they must be separated by at least 300 mm to reduce probe to probe interference.

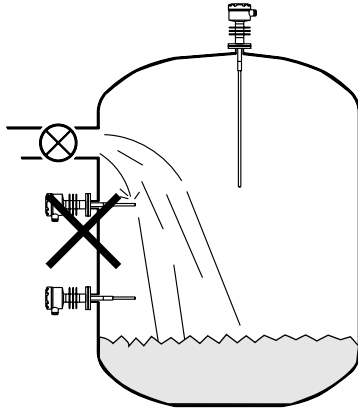

The probe should not be mounted underneath a liquid inlet otherwise it will switch on erroneously.

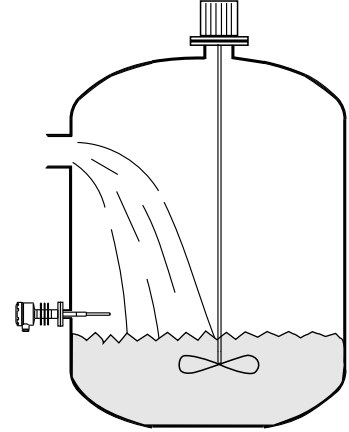

If the tank is equipped with an agitator, please use the time-delay function to stop spurious signals

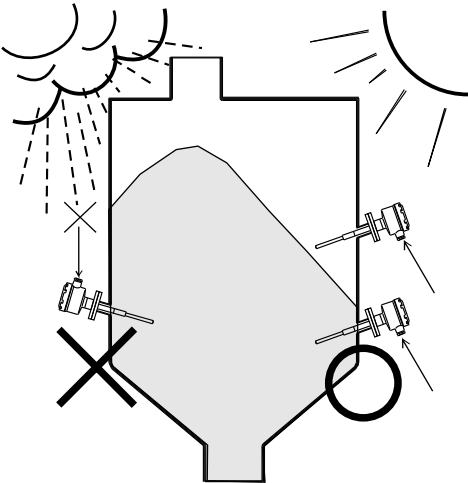

The cable inlet should face downward to avoid rainwater ingress.

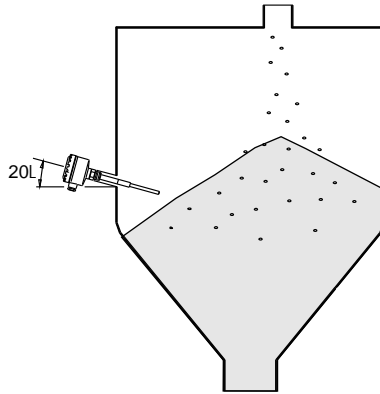

Mounting the probe at a 20° incline optimizes the results and increases the switch sensitivity.

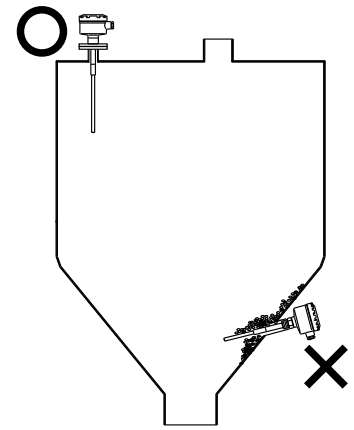

Mounting the probe at top of tank will help avoid material bridges from forming and reduce false alarms.

ORDER INFORMATION

ME **10** **A** **DT** **0250** **MD** **G**

Model

- 10 --- Standard Type
- 20 --- Hi-temp. Type
- 30 --- Corrosion Proof Type
- 40 --- Remote Probe Type
- 50 --- Wire Probe Type
- 60 --- Plate Type
- 80 --- Anti-static Type
- 90 --- Low Cost (BSP or NPT Only)

Terminal Arrangement

- A---110/220VAC
- B---DC24V, Relay output
- C---DC24V, NPN transistor output
- D---Designed for use with EX-75U

Connection

| <u>Flange / screw</u> | <u>flange rating</u> | |
|-----------------------------------------------------------|------------------------------|-----------|
| C---3/4" (20mm) | M---JIS 5kg/cm ² | W---PN 10 |
| D---1" (25mm) | N---JIS 10kg/cm ² | X---PN 16 |
| E---1-1/2"(40mm) | O---ANSI 150 Lbs | Y---PN 25 |
| F---2" (50mm) | P---ANSI 300 Lbs | Z---PN 40 |
| G---2-1/2"(65mm) | Q---PT | |
| H---3" (80mm) | R---PF | |
| I---4" (100mm) | T---BSP | |
| J---5" (125mm) | S---Others | |
| K---6" (150mm) | L---NPT | |
| S---Others (please consult office with your requirements) | | |

Probe Length (mm)

- Tolerance of the total product length is ±5mm.

MD

New housing with integral failsafe High and Low selector and 2 x M20 entry enclosure

Ground level test (G)

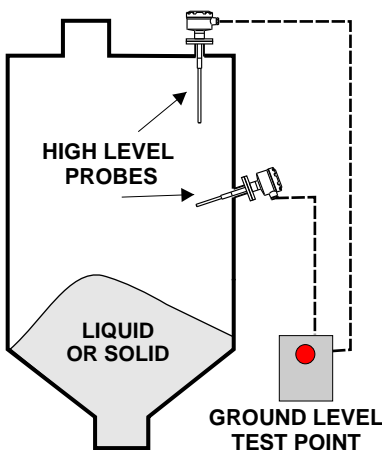

Capacitance switches with this option have an additional pair of terminals provided in the switch head that simply require a push button switch to connect these two terminals together and this is usually mounted at *ground level local to the silo fill point.*

After pushing the button, the circuit is then loaded as if a product has touched the active part of the probe and the electronics (if working correctly) will detect this change and activate the relay to change its state. Any audio or visual alarms wired to this relay will then be activated and will continue until the ground level test button is released. If the test is successful then the operator can proceed to fill the silo confident that the high alarm will operate if required to do so.

Hycontrol provide a complete alarm and test panel solution for single or multi-point applications, however a simple push button can easily be retrofitted to existing panel installation with little or no disruption to the plant operations providing the alarms and sirens already exist.

HYCONTROL LEVEL TECHNOLOGIES

Product Range For Solids :-

- (1) TDR Radar For Solids
- (2) Ultrasonic, 'Through Air'
- (2) 2 Wire Ultrasonic Transmitter
- (3) FMCW 2 Wire Radar
- (4) Continuous 'Servo' Level Indicator
- (5) FMCW 2 Wire Radar
- (6) Capacitance Level Switch
- (7) Vibrating Probe Level Switch
- (8) Rotating Paddle Level switch
- (9) Microwave Level Switch
- (10) Doppler Flow Switch

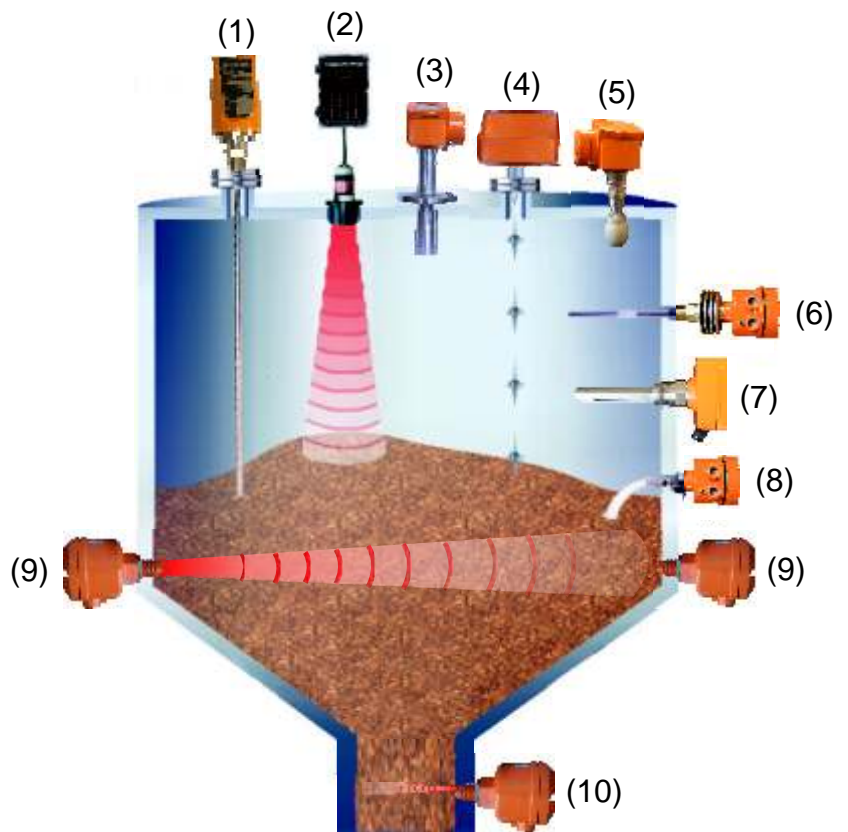

Product Range For Liquids :-

- (1) By-Pass Level Indicator With Radar
- (2) TDR Radar For Liquids
- (3) 2 Wire Ultrasonic Transmitter
- (4) FMCW 'Horn' Radar 2 Wire
- (5) Magnetic Float Switches
- (6) FMCW 2 Wire Radar
- (7) Capacitance Level Switch
- (8) RF Admittance Level Switch
- (9) Side Mounting 316 SS Float Switch
- (10) Tuning Fork Level Switch
- (11) Tuning Fork Level Switch
- (12) Ultrasonics 'Through Wall'
- (13) Mini Magnetic Float Level Switch

