

Type 595XP

Explosion-Proof I/P Transducer

High level of regulation accuracy and repeatability for the operation of actuated valves

The Type-595XP Explosion-proof I/P (current to pressure) transducer converts a 4–20mA electrical current signal to a proportionally linear pneumatic output. The unique conversion technology utilizing open loop control provides a high level of accuracy and repeatability for the operation of actuated valves. A low mass control circuit provides consistent output in high vibration applications. This compact unit is housed in an explosion proof enclosure that is designed for pipe, bracket or direct manifold mounting. This explosion-proof and intrinsically safe field device is available with an integral volume booster or as a low-flow signal converter that directly mounts to a pneumatic valve positioner. The Type-595XP has worldwide agency approvals for use in hazardous areas.

Features

- **Compact Design**
Small size and low weight
- **Worldwide Safety Approvals**
Factory Mutual (FM), Canadian Standards Association (CSA) and ATEX
- **Vibration and Position Insensitive**
Unit can be mounted in any plane and is stable in high vibration environments
- **Low power consumption**
Minimize loop load



ControlAir Inc.

Type 595XP

Explosion-Proof I/P Transducer

DIMENSIONS ^{IN}
[MM]

Ported with Flow Booster (P)

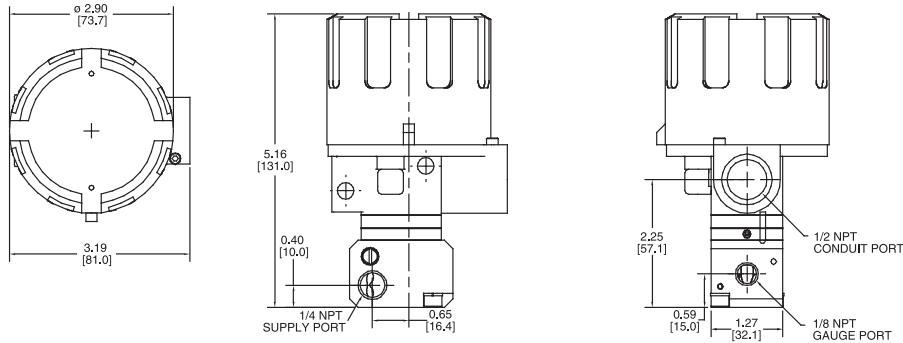

Manifold Mount without Flow Booster (M)

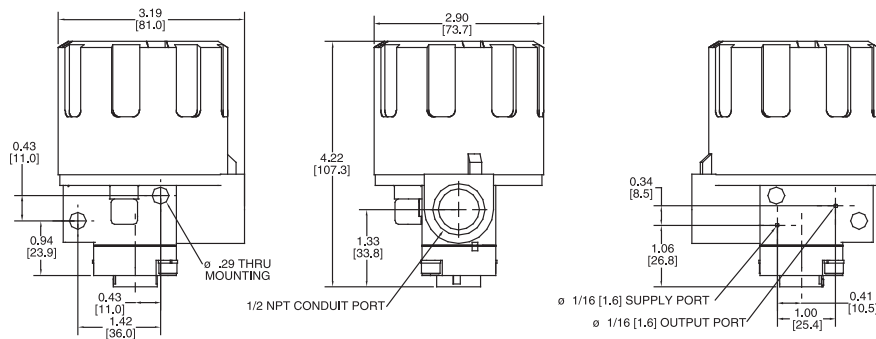

Ported without Flow Booster (N)

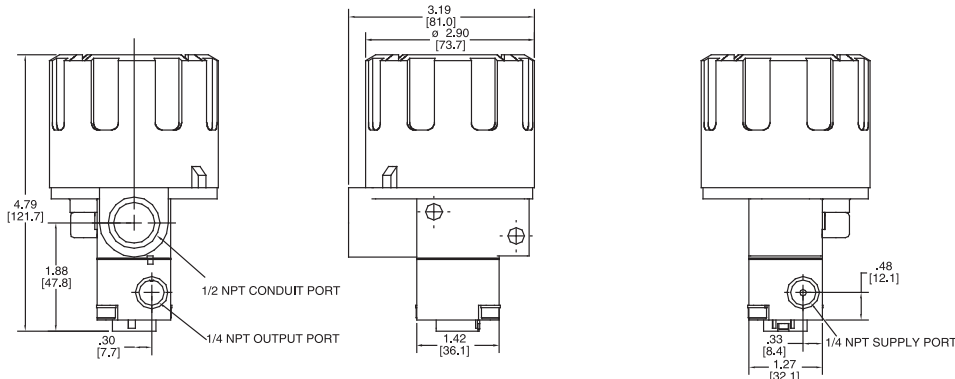

Optional 2" Bracket

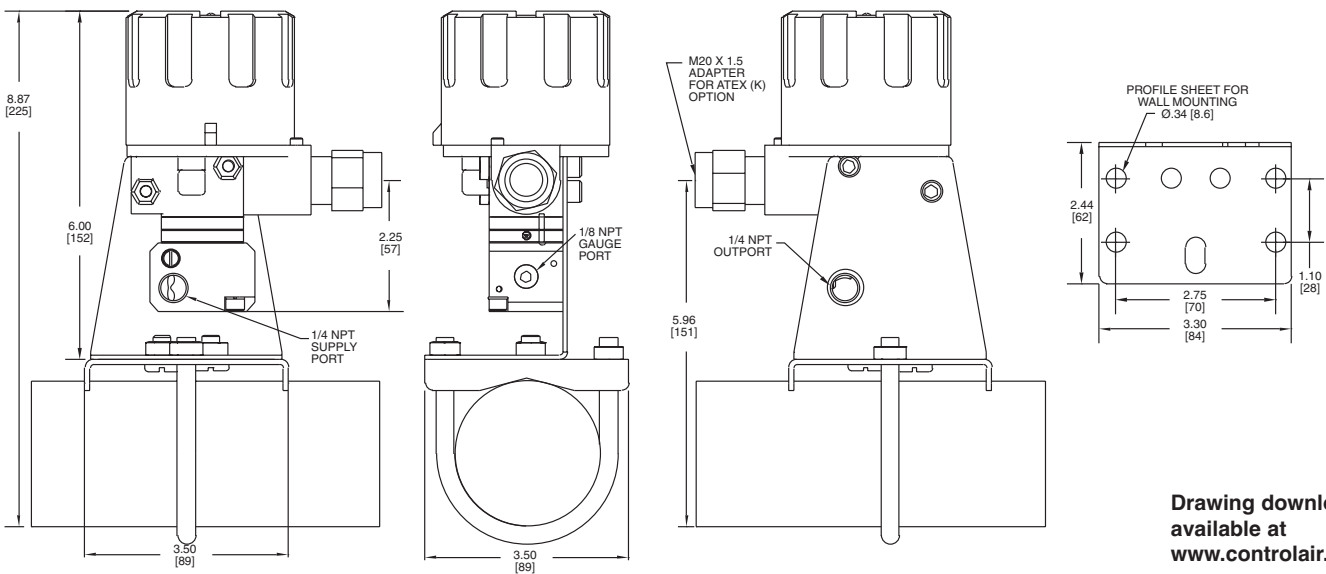



FUNCTIONAL SPECIFICATIONS

	P Connection (with Flow Booster)	M & N Connection (without Flow Booster)
Input	4-20 MA	
Outputs	3-15 psig 0.20-1.0 BAR 3-27 psig 0.20-1.8 BAR 6-30 psig 0.40-2.0 BAR	
Air Consumption	0.1 scfm (0.17m3/hr)	2.00 scfh (0.06 m3/hr) @ 20 psig supply (1.4 BAR) 4.94 scfh (0.14 m3/hr) @ 85 psig supply (6.0 BAR) 8.36 scfh (0.24 m3/hr) @150 psig supply (10.0 BAR)
Supply Pressure Note: Supply pressure must be a minimum of 5 psig (0.3 BAR) above maximum output	3-15: 22 psig (1.5 BAR) max 3-27, 6-30: 42 psig (2.8 BAR) max	150 psig (10.0 BAR) max.
Flow Capacity	2.4 scfm (4.1 m3/hr)max.	Same as Air Consumption
Temperature Limits	-67°F to 185°F (-55°C to 85°C)	
Relative Humidity	75% average - 95% short time non-condensing	
Impedance	260 Ohms @ 70°F	
Loop Load	5.2 Volts @ 70°F	

PERFORMANCE SPECIFICATIONS

Linearity (Independent)	<±0.5% of span	
Hysteresis	<±0.3% of span	
Deadband	<±0.1% of span	
Repeatability	<±0.3% of span; <±0.15% of span typical	
Mounting Orientation Effect	<±0.5% / 90 degree change	
Air Supply Sensitivity	<.3% / 1.5 (0.10 BAR) psig change	<±0.6% / 25 (1.72 BAR) psig change
Vibration Effect	<±1% up to 10g and 20-80 Hz	
Temperature Effect	<±0.75% / 10°F (5.6°C) change	

PHYSICAL SPECIFICATIONS

Housing	NEMA 4X (IP 65)
Port Sizes	Pneumatic: 1/4" NPT (P & N versions); 1/16" manifold mount (M version) 1/8" NPT Gauge Port (P version) Electric: 1/2" NPT, M20-1.5 (ATEX)
Media	Clean, dry, oil-free, instrument air, filtered to 40 micron
Electrical Connections	Terminal block
Mounting	Direct (standard) or 2" pipe (optional)
Materials	Housing: Chromate-treated aluminum with epoxy paint. NEMA 4X (IP65) Elastomers: Buna-N Trim: Stainless steel; brass; zinc-plated steel
Weight	P version = 1.40 lbs (0.64 kg) N version = 1.25 lbs (0.57 kg) M version = 1.20 lbs (0.54 kg)

Hazardous Area Type 595XP Classifications

Ordering Information

Factory Mutual (FM) & Canadian Standards Association (CSA)*

	Entity Parameters	Temperature Code	Enclosure
Intrinsic Safety Class I, Division 1, Groups A, B, C & D Class II, Division 1, Groups E, F, & G Class III, Division 1; Fibers	$V_{max} = 40 \text{ Vdc}$ $I_{max} = 150 \text{ mA}$ $P_i = 0.7 \text{ W}$ $C_i = 0 \text{ nF}$ $L_i = 0 \text{ mH}$	T4 -40°C ≤ Ta ≤ 75°C	Nema-4X
Nonincendive Class I, Division 2, Groups A, B, C & D Class II, Division 2, Groups E, F, & G Class III, Division 2; Fibers		T4 -40°C ≤ Ta ≤ 75°C	
Explosion-Proof Class I, Division 1, Groups B, C & D Dust Ignition Proof Class II & III, Division 1, Groups E, F, & G	---	T6 -40°C ≤ Ta ≤ 75°C	Nema-4X

*CSA Pending

ATEX*

	Entity Parameters	Temperature Code	Enclosure
Intrinsic Safety Ex II 1 G Ex ia IIC	$V_{max} = 40 \text{ Vdc}$ $I_{max} = 150 \text{ mA}$ $P_i = 0.7 \text{ W}$ $C_i = 0 \text{ nF}$ $L_i = 0 \text{ mH}$	T** -55°C to Ta Max**	IP65
Flameproof Ex II 2 G Ex d II B + H2 Ex II 2 D Ex tD A21 T85°C	---	T6 -40°C ≤ Ta ≤ +75°C	IP65
Limited Energy/Non-Sparking Ex II 3 G Ex nL IIC Ex II 3 G Ex nA nL IIC	---	T* -55°C to Ta Max* T6 -55°C ≤ Ta ≤ +85°C	IP65

**See energy limiting parameters. Refer to Instruction Manual 441-622-099.

*ATEX Pending



Use this coding system to order

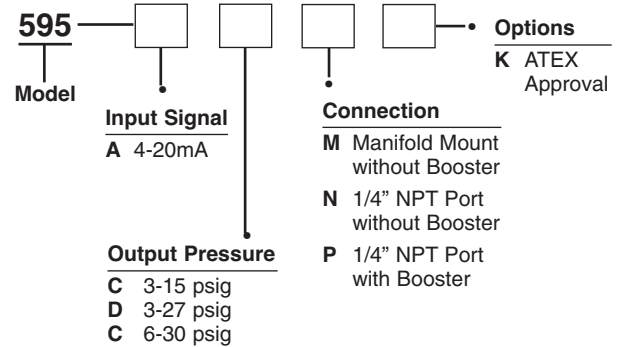

Accessories:

2" Pipe Bracket Mounting Kit: P/N 448-542-016

Warranty

ControlAir, Inc. products are warranted to be free from defects in materials and workmanship for a period of eighteen months from the date of sale, provided said products are used according to ControlAir, Inc. recommended usages. ControlAir, Inc.'s liability is limited to the repair, purchase price refund, or replacement in kind, at ControlAir, Inc.'s sole option, of any products proved defective.

ControlAir, Inc. reserves the right to discontinue manufacture of any products or change products materials, designs or specifications without notice. Note: ControlAir does not assume responsibility for the selection, use, or maintenance of any product. Responsibility for the proper selection, use, and maintenance of any ControlAir product remains solely with the purchaser and end user.



8 Columbia Drive / Amherst, NH 03031 USA
 Website: www.controlair.com
 Email: sales@controlair.com
 603-886-9400 FAX 603-889-1844

