



P200 / P290

Ordering Information

Part Number	Description
P200	P/I Device, 2-wire, FM explosion-proof, 4-20/10-50 mA* Field selectable
P290M	P/I Module, 2-wire, 4-20 mA output
P290DC	Adapter for C type rail -optional
P290DG	Adapter for G type rail -optional

*10-50 mA not available with P28 or P30 options

*For stand alone operation, P290M and P290MV require either C or G Din Rail Adapter



Approvals

The Dahl P200 has been approved by Factory Mutual and the Canadian Standards Association as NEMA 4 (Enc. 4) for all locations and explosion-proof for Class I, Div. 1, Groups A, B, C, D; dust ignition-proof for Class II, Div. 1, Groups E, F, G; and suitable for Class III, Div. 1 locations. FM and CSA intrinsic safety and nonincendive approvals for all hazardous areas have been granted using most major zener barrier systems. Contact ControlAir for further details.

INPUT RANGES - P200 AND P290

P/N	Standard Ranges	P/N	Custom Ranges (psig) Specify range
P11	3-15 psig (20-100 kPa)	P50	0-.72 to 0-6.0
P12	3-27 psig (20-180 kPa)	P51	0-6.0 to 0-18.0
P13	6-30 psig (40-200 kPa)	P52	0-18.0 to 0-30.0
		P53	0-30.0 to 0.50.0*

* FM and CSA explosion-proof approvals not applicable above 30 psig

OPTIONS

P200		P290	
P/N	Description	P/N	Description
P21	Lightening Surge Protector	P31	CSA general purpose certification
P22	2" Pipe, "U"-Bolt Hardware		
P23	Extra 316 SS Tag		
P27*	Internal Meter, NEMA 4		
P28	CSA Intrinsically Safe		
P29	CSA Explosion-proof		
P30	FM Intrinsically Safe		

*Transmitters with P27 option are not FM or CSA approved, explosion-proof

Part Number = Model + Input Range + Options

Examples: P200 + P11 + P21
P290 + P50 (0-5)

Warranty

ControlAir, Inc. products are warranted to be free from defects in materials and workmanship for a period of eighteen months from the date of sale, provided said products are used according to ControlAir, Inc. recommended usages. ControlAir, Inc.'s liability is limited to the repair, purchase price refund, or replacement in kind, at ControlAir, Inc.'s sole option, of any products proved defective. ControlAir, Inc. reserves the right to discontinue manufacture of any products or change products materials, designs or specifications without notice. Note: ControlAir does not assume responsibility for the selection, use, or maintenance of any product. Responsibility for the proper selection, use, and maintenance of any ControlAir product remains solely with the purchaser and end user.



8 Columbia Drive / Amherst, NH 03031 USA
 Website: www.controlair.com
 Email: sales@controlair.com
 603-886-9400 FAX 603-889-1844





P200 / P290

User-friendly, compact and versatile pneumatic-to-electric transducers

S P E C I F I C A T I O N S

	DAHL P200	DAHL P290
Inputs	Instrument Air: 3-15 psig (20-100 kPa) 3-27 psig (20-180 kPa) 6-30 psig (40-200 kPa)	
Maximum Input	3 times full scale without recalibration 4 times full scale without failure	
Outputs	P200, 2 wire: 4-20 mA and 10-50 mA with over-current limit	P290M, 2 wire: 4-20 mA, with over-current limit.
Allowable Loads (24 VDC Power)	700 Ω	2-wire: 700 Ω , standard.
Accuracy	$\pm 0.15\%$ of span guaranteed; $\pm 0.10\%$ of span typical. Includes combined effects of linearity, hysteresis and repeatability errors	
Hysteresis	Negligible	
Repeatability	$\pm 0.10\%$ of span max; $\pm 0.03\%$ of span typical	
Resolution	Infinite	
Output Ripple	None	
Protection	N/A	Reverse polarity, transient, over-current
Response Time	10 m Sec to 99% of step change	
Temperature Stability	Span and Zero: $\pm 0.007\%$ of span per $^{\circ}\text{F}$ maximum deviation from 77°F calibration	
Power Supply Stability	Less than 0.005% of span change in output per volt change at the input terminals	
Power Supply	10 VDC min. to 42 VDC max. at input terminals. Can indefinitely withstand up to 100 VDC without failure	10 VDC min. to 42 VDC max. at input terminals
RFI/EMI Effect	Meets or exceeds SAMA PMC 33.1, 1978, 2-abc: 0.1% of span at 10 volts/meter	
Operating Temperature Range	-40 $^{\circ}\text{F}$ to 161 $^{\circ}\text{F}$ (-40 $^{\circ}\text{C}$ to 72 $^{\circ}\text{C}$)	-40 $^{\circ}\text{F}$ to 167 $^{\circ}\text{F}$ (-40 $^{\circ}\text{C}$ to 75 $^{\circ}\text{C}$)
Storage Temperature Range	-60 $^{\circ}\text{F}$ to 161 $^{\circ}\text{F}$ (-51 $^{\circ}\text{C}$ to 72 $^{\circ}\text{C}$)	-60 $^{\circ}\text{F}$ to 185 $^{\circ}\text{F}$ (-51 $^{\circ}\text{C}$ to 85 $^{\circ}\text{C}$)
Calibration Adjustments	Multiturn span and zero potentiometers with approximately $\pm 20\%$ of span adjustment range	Non-interactive, multiturn span and zero potentiometers with approximately $\pm 10\%$ of span adjustment range
Loss-of-air Indication	N/A	LED illuminates when input pressure falls below 60% of the live-zero input or, on optional alarm units, LED illuminates during alarm condition
Mounting Position Effect	None	
In-process Output Monitoring	Current: For accurate reading, ammeter must have less than 20 Ω input resistance on 4-20 mA output (0.40 VDC drop)	
Connections	Signal Air: 1/4" NPT female Electrical Wiring: 1/2" NPT female to barrier terminal strip	Signal Air: 1/8" NPT female Electrical Wiring: Miniature terminal block accepts solid or stranded wire up to 14 AWG



P200 / P290

Dimensions

P200

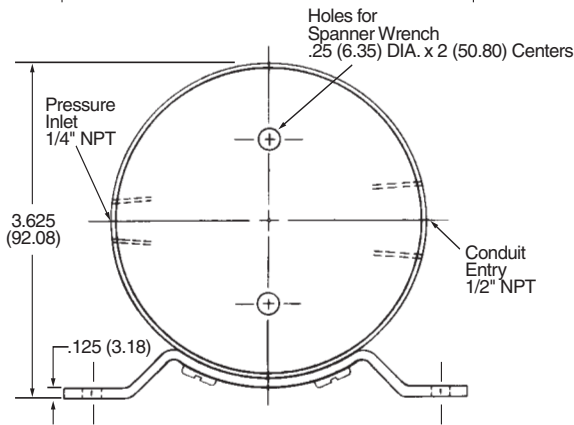
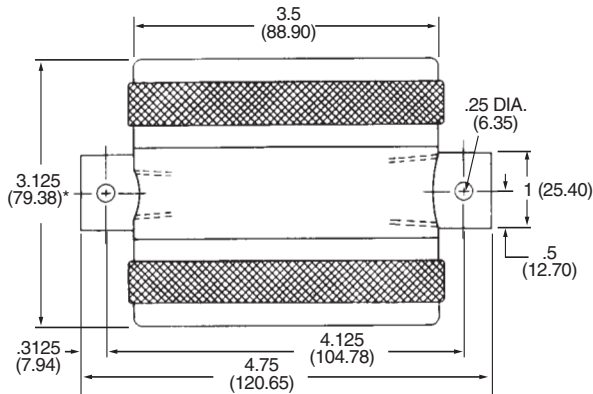

*Allow 1" (25.40) each end for removal of covers

P200 2" Pipe, "U" Bolt Mounting-Option P22

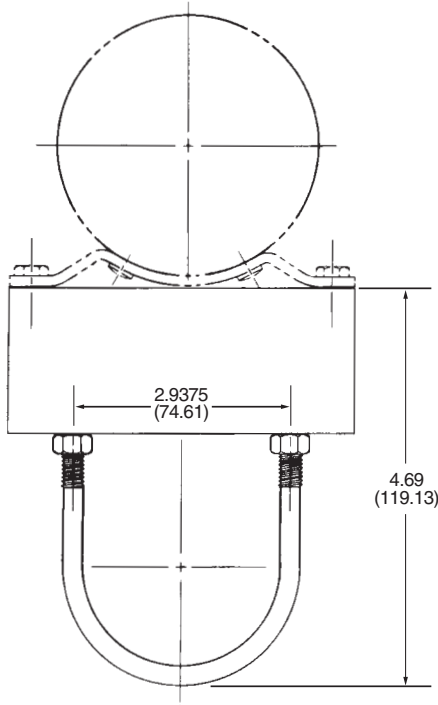

P290 with optional C or G Din Rail Adapter

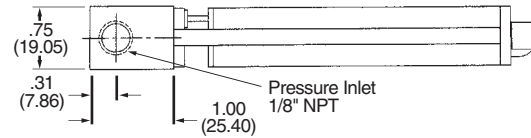

P290 with optional C type Din Rail Adapter

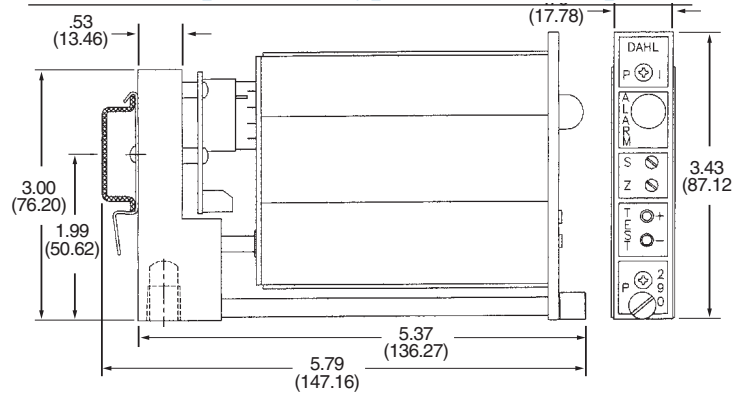

P290 with optional G type Din Rail Adapter



Principles of Operation

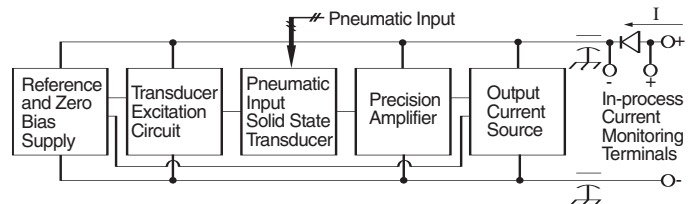

A precision voltage reference circuit supplies a stable and highly regulated voltage to all other portions of the circuit. An excitation circuit drives the solid state, piezo-resistive transducer which has the configuration of a Wheatstone Bridge. Upon the application of pressure to the transducer, a force and resultant strain causes the bridge to become unbalanced in direct proportion to the applied pressure. The voltage thus obtained is amplified, scaled, and summed with another reference voltage to produce the output current source signal.