



## ADMITTANCE LEVEL SWITCHES



# PRODUCT INTRODUCTION

---

The Hycontrol range of Admittance level switches provide simple, accurate and reliable level control for a wide range of applications. They are suitable for use on liquids, solids, slurries, pastes, granules, powders and pellets in high temperature, high pressure and corrosive environments.

The main advantage offered by using this admittance range of switches is their ability to totally ignore product build up on the sensing probe.

This unique design utilises a protective insulation electrode between the conventional main electrode and the grounding sleeve which enables the electronics to distinguish between coatings and actual product level.

This technology also provides an ideal solution for interface detection applications such as oil on water and liquid detection underneath a layer of foam.

## SWITCH FEATURES

- Unaffected by material coating on the sensing probe
- No moving parts to wear out
- Easy installation through a 1" BSP process fitting
- High corrosion and chemical resistance as standard options
- Universal mounting for high or low level detection
- Multiple versions with rod and cable to simplify mounting options
- High temperature versions available
- Low maintenance technology with no moving parts
- Hazardous area certified versions ATEX approved
- Adjustable sensitivity for a wide range of products
- Adjustable time delay to stop spurious signals from surface ripple
- Remote electronics option for high vibration applications
- Interface level detection
- High and low failsafe selection options

## TYPICAL APPLICATIONS

- Acid Tanks and silos
- Bitumen, Tar and Asphalt
- Adhesives, Polymers and Paints
- Syrups and pastes
- Powders, flakes and granules

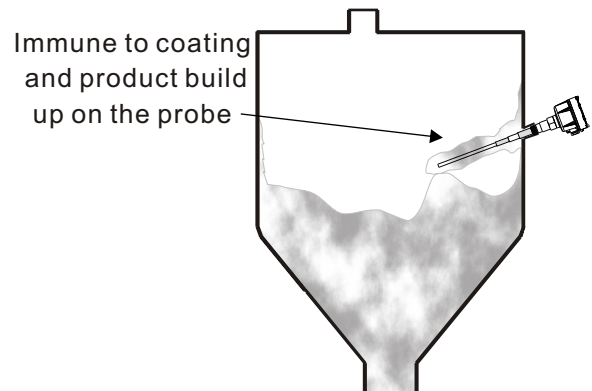

# CONSTRUCTION & APPLICATION

---

## Construction

1. Main Contact Probe:  
SUS304 or SUS316 Material
2. Main Insulation Probe:  
Insulation of main Probe and reference current, made of either PTFE or PFA.
3. Reference Current:  
Conductive metal probe to dissipate any possible presence of false signal.
4. Insulation Probe:  
To protect contact probe and external insulation probe, having very low current inducing characteristics and is made of either PTFE or PFA.
5. Process Connection:  
1" BSP (Standard model)
6. Housing:  
Aluminum Alloy with paint finish
7. Electrical Entry:  
1/2" NPT
8. Housing seal:  
Buna N 'O' Ring
9. Time Delay:  
FSH and FSL, Time Delay Adjustable function
10. Housing Cover:  
Aluminum Alloy Spray Paint

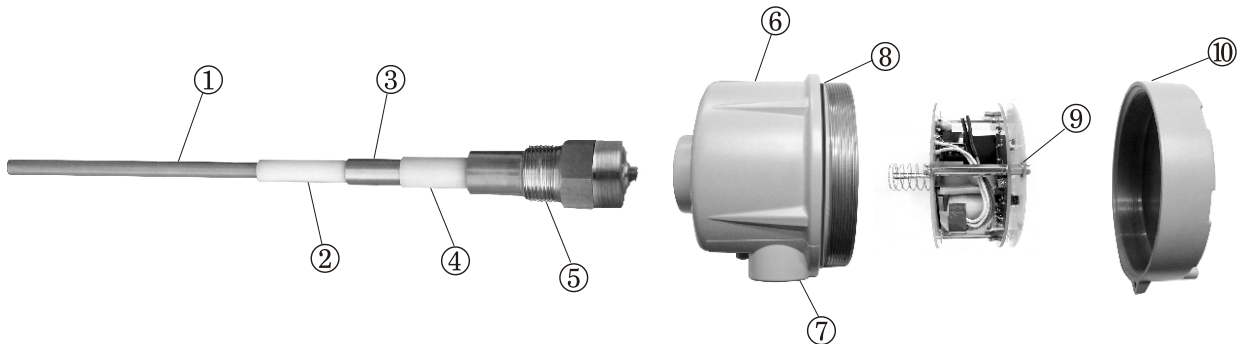

## Industry Applications

- Brewery Plant
- Chemical Plant
- Cement Plant
- Coal Plant
- Food Processing Plant
- Flour Mill
- Glass Industry
- Paint Plant
- Plastics Plant
- Quarrying Plant
- Aggregate Plant
- Mining Plant
- Paper Manufacturing Plant
- Medical Plant
- Power Plant
- Water and Waste Water Treatment Plant
- Tar Factory
- Beverage Plant
- Bitumen Coating Plant
- Dairy Plant
- Automotive Plant

# SPECIFICATION

<p>Dimension (mm)</p>			
<p><b>Model</b></p>	<p><b>MD 11 [Standard Model] MD 12 [Standard L Type]</b></p>	<p><b>MD 20 [Hi-Temp Model]</b></p>	<p><b>MD 1280 [Hi-Temp Model]</b></p>
<p><b>Operating Temp.</b></p>	<p>-40°C~150°C</p>	<p>-40°C~232°C</p>	<p>-40°C~550°C</p>
<p><b>Ambient Temp.</b></p>	<p>-40°C~65°C</p>	<p>-40°C~65°C</p>	<p>-40°C~65°C</p>
<p><b>Housing</b></p>	<p>Aluminium (IP65)</p>	<p>Aluminium (IP65)</p>	<p>Aluminium (IP65)</p>
<p><b>Probe Material</b></p>	<p>304SS or 316SS</p>	<p>304SS or 316SS</p>	<p>304SS or 316SS</p>
<p><b>Insulation</b></p>	<p>PTFE or PFA</p>	<p>PTFE or PFA</p>	<p>Ceramic</p>
<p><b>Connection</b></p>	<p>3/4" BSP</p>	<p>1" BSP</p>	<p>1-1/4" BSP</p>
<p><b>Sensitivity</b></p>	<p>0.3PF</p>	<p>0.3PF</p>	<p>0.3PF</p>
<p><b>Supply Voltage</b></p>	<p>110/220VAC±10% 50/60HZ</p>	<p>110/220VAC±10% 50/60HZ</p>	<p>110/220VAC±10% 50/60HZ</p>
<p><b>Power Consumption</b></p>	<p>3~5 W</p>	<p>3~5 W</p>	<p>3~5 W</p>
<p><b>Contact Rating</b></p>	<p>5A/250VAC, DPDT</p>	<p>5A/250VAC, DPDT</p>	<p>5A/250VAC, DPDT</p>
<p><b>Delay Time</b></p>	<p>0~90 sec</p>	<p>0~90 sec</p>	<p>0~90 sec</p>
<p><b>Fail safe mode</b></p>	<p><b>High / low Selectable</b></p>	<p><b>High / low Selectable</b></p>	<p><b>High / low Selectable</b></p>
<p><b>Conduit</b></p>	<p>Dual M20 Entry</p>	<p>Dual M20 Entry</p>	<p>Dual M20 Entry</p>
<p><b>Operation Pressure</b></p>	<p>20kg/cm<sup>2</sup></p>	<p>20kg/cm<sup>2</sup></p>	<p>20kg/cm<sup>2</sup></p>
<p><b>Weight</b></p>	<p>1.7kg</p>	<p>3.5kg</p>	<p>4.2kg</p>

# SPECIFICATION

<p>Dimension (mm)</p>			
<p><b>Model</b></p>	<p><b>MD49 [Separation Model]</b></p>	<p><b>MD50 [Cable Model]</b></p>	<p><b>MD60 [Mini Model]</b></p>
<p><b>Operating Temp.</b></p>	<p>-40°C~150°C, MAX 550°C</p>	<p>-40°C~150°C</p>	<p>-40°C~150°C</p>
<p><b>Ambient Temp.</b></p>	<p>-40°C~65°C</p>	<p>-40°C~65°C</p>	<p>-40°C~63°C</p>
<p><b>Housing</b></p>	<p>Stainless (IP65) Aluminium (IP65)-separation</p>	<p>Aluminium (IP65)</p>	<p>Aluminium (IP65)</p>
<p><b>Probe Material</b></p>	<p>304SS OR 316 SS</p>	<p>304SS OR 316 SS</p>	<p>304SS OR 316 SS</p>
<p><b>Insulation</b></p>	<p>PTFE or PFA</p>	<p>PTFE or PFA</p>	<p>PTFE or PFA</p>
<p><b>Connection</b></p>	<p>3/4" BSP</p>	<p>3/4" BSP</p>	<p>3/4" BSP</p>
<p><b>Sensitivity</b></p>	<p>0.3PF</p>	<p>0.3PF</p>	<p>0.3PF</p>
<p><b>Supply Voltage</b></p>	<p>110/220VAC±10% 50/60HZ</p>	<p>110/220VAC±10% 50/60HZ</p>	<p>110/220VAC±10% 50/60HZ</p>
<p><b>Power Consumption</b></p>	<p>2.3 W</p>	<p>2.3 W</p>	<p>2.3 W</p>
<p><b>Contact Rating</b></p>	<p>5A/250VAC, DPDT</p>	<p>5A/250VAC, DPDT</p>	<p>5A/250VAC, DPDT</p>
<p><b>Delay Time</b></p>	<p>0~90 sec</p>	<p>0~90 sec</p>	<p>0~90 sec</p>
<p><b>Fail safe mode</b></p>	<p><b>High / low Selectable</b></p>	<p><b>High / low Selectable</b></p>	<p><b>High / low Selectable</b></p>
<p><b>Conduit</b></p>	<p>Dual M20 Entry</p>	<p>Dual M20 Entry</p>	<p>Dual M20 Entry</p>
<p><b>Operation Pressure</b></p>	<p>20kg/cm<sup>2</sup></p>	<p>20kg/cm<sup>2</sup></p>	<p>20kg/cm<sup>2</sup></p>
<p><b>Weight</b></p>		<p>Depend on cable length</p>	

# WIRING DIAGRAM

- Ensure the power supply is shut off
- Pull the power lines through the cable inlet into the housing
- Power supply voltage is selected at 110V or 220V, but the live wire must be connected to their respective terminals, 110V live wire to 110V terminal, 220V live wire to 220V terminal. The neutral line can be connected to 0V terminal and the ground line is to be connected to the GND terminal
- Relay output connection:  
Relay outputs are set at SPDT or DPDT, maximum switching current and voltage is 5A/250VAC, which can drive small loads such as: solenoid valves, alarm sirens, etc. Bigger loads require a larger relay to drive it. The diagrams below and on the right are common examples of wiring methods.

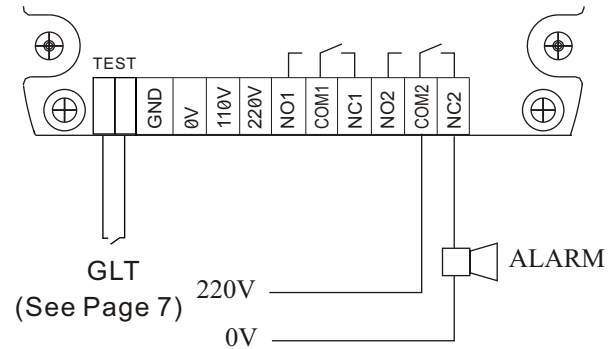

## Fail safe mode:

Fail safe mode is used primarily to detect malfunction situations. Example: Power supply disruptions, causing the relay to lose it's driving voltage, this type of situation is called fail safe, meaning that in cases of black out, there will be an alarm signal. The fail safe mode "FSH" and "FSL" selection is dependent on the installation position of the probe, the table below shows the fail safe conditions of each mode:

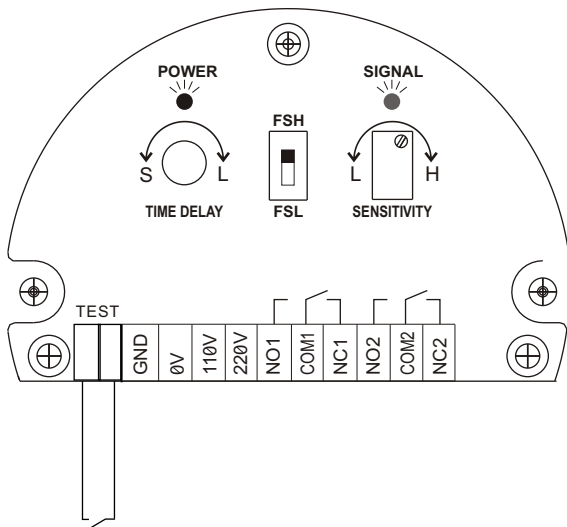

Ground level test connection for simple push button switch, volt free contact.

### High fail safe mode

Condition	Probe in contact with medium	Probe not in contact with medium
Signal light Indicator	Light	Dim
Relay	Not Energized	Energized
N.C. Contact	Closed	Open
N.O. Contact	Open	Closed

### Low fail safe mode

Condition	Probe in contact with medium	Probe not in contact with medium
Signal light Indicator	Light	Dim
Relay	Energized	Not Energized
N.C. Contact	Open	Closed
N.O. Contact	Closed	Open

# ORDER INFORMATION

MD   - A         G

**Model**

- MD11: Standard Model
- MD20: Hi-Temp Model
- MD20: Super Hi-Temp Model
- MD49: Separation Model
- MD50: Cable Model
- MD60: Mini Model

**Power Supply**

A 110/220v

**Connection**

D---1"(25A)	M---5kg/cm <sup>2</sup>	Q---PT
E---1-1/2"(40A)	N---10kg/cm <sup>2</sup>	R---PF
F---2"(50A)	O---150 Lbs	T---BSP
G---2-1/2"(65A)	P---300 Lbs	U---NPT
H---3"(80A)	W---PN 10	S---Others
I---4"(100A)	X---PN 16	
J---5"(125A)	Y---PN 25	
K---6"(150A)	Z---PN 40	
S---Others		

**Probe Length (unit: mm)**

Customized specifications are available upon request, please contact Hycontrol.

Explosion proof and ATEX certification will be available shortly. Please contact Hycontrol before quoting.

**Ground level test (G)(Standard Feature)**

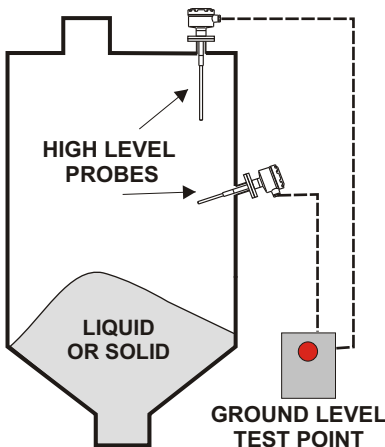

Admittance switches with this option have an additional pair of terminals provided in the switch head that simply require a push button switch to connect these two terminals together and this is usually mounted at *ground level local to the silo fill point.*

After pushing the button, the circuit is then loaded as if a product has touched the active part of the probe and the electronics (if working correctly) will detect this change and activate the relay to change its state. Any audio or visual alarms wired to this relay will then be activated and will continue until the ground level test button is released. If the test is successful then the operator can proceed to fill the silo confident that the high alarm will operate if required to do so.

Hycontrol provide a complete alarm and test panel solution for single or multi-point applications, however a simple push button can easily be retrofitted to existing panel installation with little or no disruption to the plant operations providing the alarms and sirens already exist.

# HYCONTROL LEVEL TECHNOLOGIES

Level product range includes :-

- (1) TDR Radar for solids
- (2) Ultrasonic, 'through air'
- (3) Continuous 'servo' level indicator
- (4) Capacitance level switch
- (5) Vibrating probe level switch
- (6) Rotating paddle level switch
- (7) By-pass level indicator with radar
- (8) TDR Radar for liquids
- (9) 2 wire Ultrasonic transmitter
- (10) FMCW 2 wire 'wavestick' Radar
- (11) Magnetic Float switches
- (12) FMCW 'Horn' Radar 2 wire
- (13) Capacitance level switch
- (14) Side mounting 316 SS float switch
- (15) Vibrating fork level switch
- (16) Ultrasonics 'through wall'
- (17) Mini magnetic float level switch
- (18) R F Admittance level switch

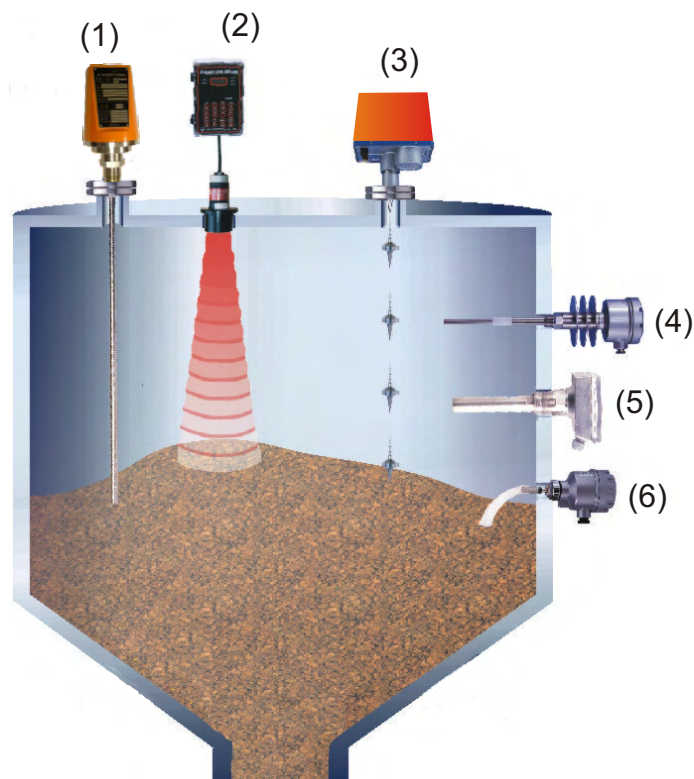

## SOLIDS

**IF YOU ARE UNSURE WHICH TECHNOLOGY TO USE FOR YOUR APPLICATION PLEASE CONSULT HYCONTROL INSTRUMENT ENGINEERS FOR APPLICATION ADVICE OR A FREE SITE LEVEL SURVEY.**

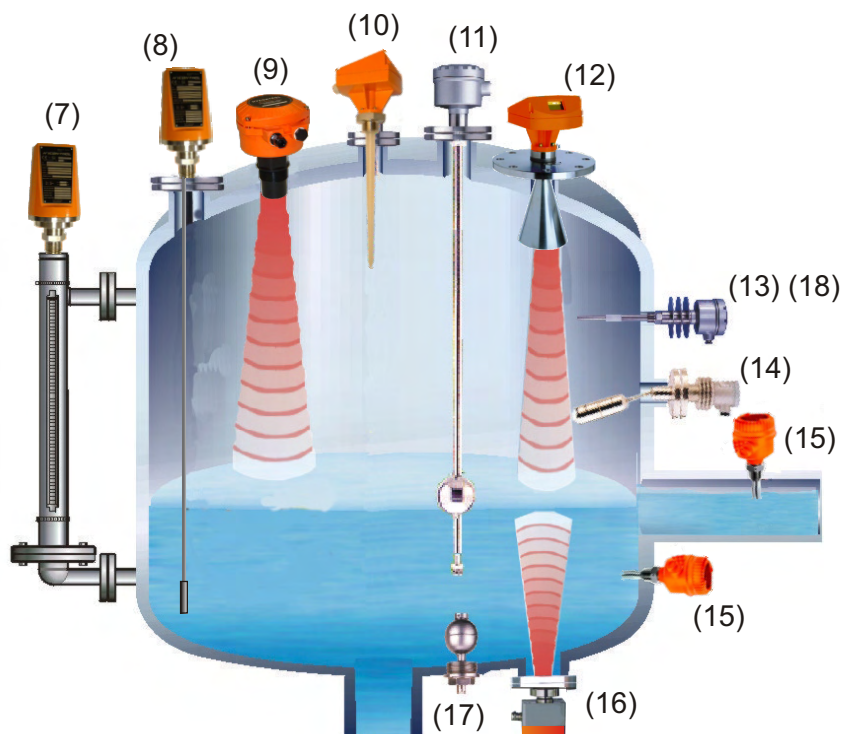

## LIQUIDS

### HYCONTROL LTD

Larchwood house  
Orchard Street  
Redditch  
Worcestershire  
England  
B98-7DP

Tel : 01527 406800  
Fax : 01527 406810

Email : [sales@hycontrol.com](mailto:sales@hycontrol.com)  
Website : [www.hycontrol.com](http://www.hycontrol.com)