



aerospace
climate control
electromechanical
filtration
fluid & gas handling
hydraulics
pneumatics
process control
sealing & shielding



High Flow NAMUR 1/4" & 1/2" valves

for actuator control



ENGINEERING YOUR SUCCESS.

General Information

Technical Data

Function	3/2, 5/2 and 5/3 solenoid and air operated valves
Manual override	Standard on all solenoid operated versions
Design	Pilot operated spool valve with combined pneumatic and spring return
Mounting	For direct mounting on NAMUR 1/4" & 1/2" interface
Mounting position	Indifferent
Material specifications	Aluminium body - Internal parts from stainless steel - Sealing material from NBR
Range of admissible pressure drop	Δp min. = see table page 4 or 6 Δp max. = 10 bar
Media	Dry or lubricated air
Fluid temperature	Minimum 0° C Maximum + 50° C
Ambient temperature	-10° C à +50° C
Electrical part	Miniature coil 496131 (3W) encapsulated in synthetic material Connection with 3-pin DIN 43650 type B plug. Degree of protection IP 65
Solenoid duty	100% ED
Voltage	12 VDC , 24 VDC , 48 VDC , 110 VDC , 24 V / 50-60 AC, 48 V / 50-60 AC, 110 V / 50-60 AC, 115 V / 60 Hz AC, 230 V / 50-60 AC
Voltage tolerance	± 10% of nominal
Class of insulation material	Class F

Applications

- 3- or 4- way directional valves for the control of single - or double acting pneumatic actuators.
- The interface design corresponds to the NAMUR standard and the VDI/VDE 3845 recommendations of the actuator industry and permits a compact design of the actuator/valve unit.

NAMUR Interfaces 1/4" & 1/2"

T	D1 mm	D2 mm	D3 mm	D4 min. Mm	M mm
1/4	32	24	8	12	M5
1/2	45	40	10	16	M6

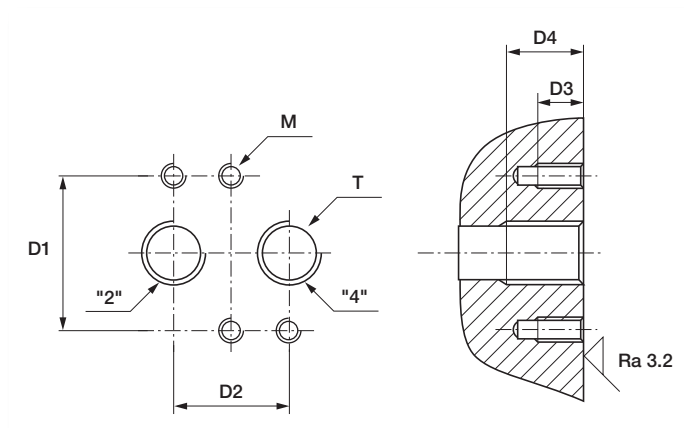

Coils

Voltage	Without DIN plug		With DIN plug		Zone ATEX 22*	
	Description	Order code	Description	Order code	Description	Order code
12VDC	22 mm standard coil 3W	496131 C1	22 mm standard coil 3W	496482 C1	22 mm Ex II 3D 3W	496637 C1
24VDC	22 mm standard coil 3W	496131 C2	22 mm standard coil 3W	496482 C2	22 mm Ex II 3D 3W	496637 C2
48VDC	22 mm standard coil 3W	496131 C4	22 mm standard coil 3W	496482 C4	22 mm Ex II 3D 3W	496637 C4
110 VDC	22 mm standard coil 3W	496131 C5	22 mm standard coil 3W	496482 C5	22 mm Ex II 3D 3W	496637 C5
24/50-60AC	22 mm standard coil 3W	496131 P0	22 mm standard coil 3W	496482 P0	22 mm Ex II 3D 3W	496637 P0
48/50-60AC	22 mm standard coil 3W	496131 S4	22 mm standard coil 3W	496482 S4	22 mm Ex II 3D 3W	496637 S4
110/50-60AC	22 mm standard coil 3W	496131 P2	22 mm standard coil 3W	496482 P2	22 mm Ex II 3D 3W	496637 P2
115/60AC	22 mm standard coil 3W	496131 K8	22 mm standard coil 3W	496482 K8	22 mm Ex II 3D 3W	496637 K8
230/50-60AC	22 mm standard coil 3W	496131 P9	22 mm standard coil 3W	496482 P9	22 mm Ex II 3D 3W	496637 P9

* Application explosive dust atmosphere (zone 22).

How to order

Valve reference No.* - Coil reference - Voltage code =

* Includes mounting kit for coil assembly + 2x NAMUR O-rings
+ 2 mounting screws and positioning dowel

Valves and coils may also be orders separately.

Order code

(non assembled)

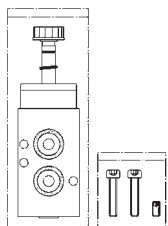

+

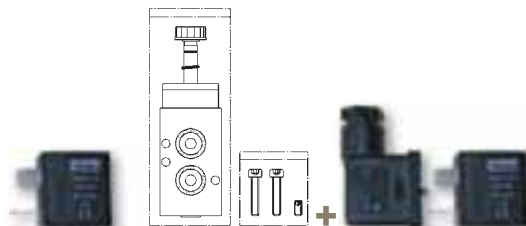

+

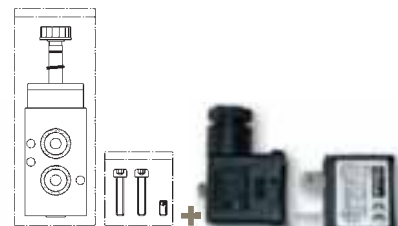

+

Example: 341 N 03 + 496131C2 =
341N03-496131C2

Example: 341 N 03 + 496482C2 =
341N03-496482C2

Example: 341 N 03 + 496637C2 =
341N03-496637C2

Spare Parts

Spare Housing

Plastic nut with O-ring

Maximum torque 0.5 Nm

Order code

3125



Spare part mounting kit

For G 1/4" models

Spare part kit includes:

2 screws DIN912 M5x25 A2, 1 pin DIN 913 M5x10 A2, 2 O-rings NBR 15x2.5

Order code

496132



For G 1/2" models

Spare part kit includes:

2 screws DIN912 M6x35 A2, 1 pin DIN 913 M6x12 A2, 2 O-rings NBR 24x3

496133



G 1/4" Serie

Port size	Orifice	Qn	Admissible differential pressure (bar)		Max. admissible fluid temperature (°C)	Seat disc	Reference number		(Watt) consumption Power		(g) Weight	Dimensions Reference
			max.				Valve	Coil	DC	AC		
G	mm	L/min	min	DC= AC~	Air & Neutral gases							

3/2 Pilot operated valve - Internal pressure supply

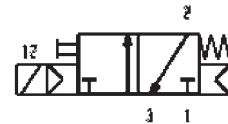

1/4	7	1250		10	10	50	NBR	331N03	496131	3	3	300	1
-----	---	------	--	----	----	----	-----	---------------	--------	---	---	-----	---

5/2 Pilot operated valve - Internal pressure supply



1/4	7	1250		10	10	50	NBR	341N03	496131	3	3	300	2
-----	---	------	--	----	----	----	-----	---------------	--------	---	---	-----	---

5/2 Control by 2 solenoids and internal pressure supply



1/4	7	1250	2	10	10	50	NBR	347N03	496131	3	3	430	3
-----	---	------	---	----	----	----	-----	---------------	--------	---	---	-----	---

5/3 Control by 2 solenoids and internal pressure supply Closed in centre position



1/4	7	1250	3	10	10	50	NBR	342N03	496131	3	3	430	4
-----	---	------	---	----	----	----	-----	---------------	--------	---	---	-----	---

3/2 Externally operated valve - External pressure supply 2.5 to 10 bar

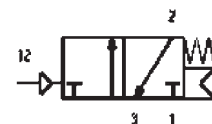

1/4	7	1250	2.5	10	10	50	NBR	531N03	-	-	-	210	5
-----	---	------	-----	----	----	----	-----	---------------	---	---	---	-----	---

5/2 Externally operated valve - External pressure supply 2.5 to 10 bar



1/4	7	1250	2.5	10	10	50	NBR	541N03	-	-	-	210	6
-----	---	------	-----	----	----	----	-----	---------------	---	---	---	-----	---

5/2 Externally operated valve - 2 x External pressure supply 2 to 10 bar



1/4	7	1250	1.5	10	10	50	NBR	547N03	-	-	-	240	7
-----	---	------	-----	----	----	----	-----	---------------	---	---	---	-----	---

5/3 Externally operated valve - 2 x External pressure supply 3 to 10 bar Closed in centre position

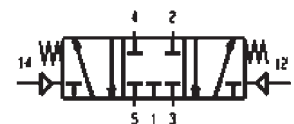

1/4	7	1250	1.5	10	10	50	NBR	542N03	-	-	-	210	8
-----	---	------	-----	----	----	----	-----	---------------	---	---	---	-----	---

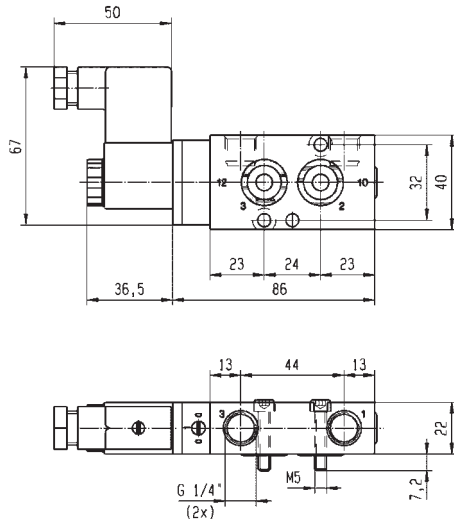

Dimensions Reference 1

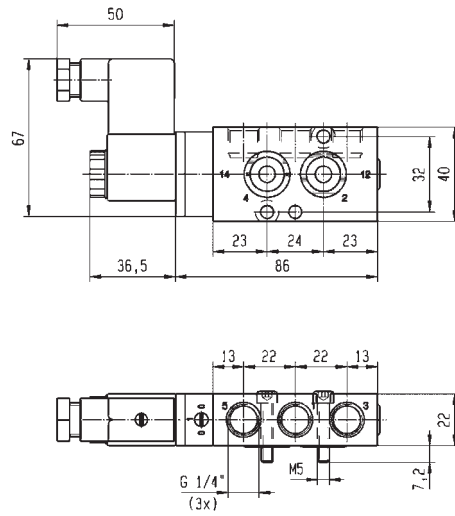

Dimensions Reference 2

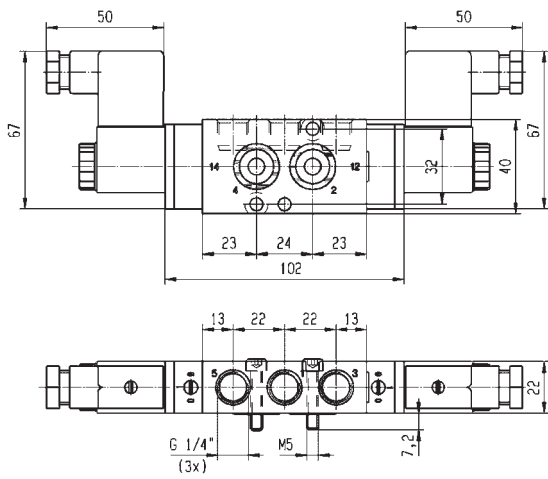

Dimensions Reference 3 & 4

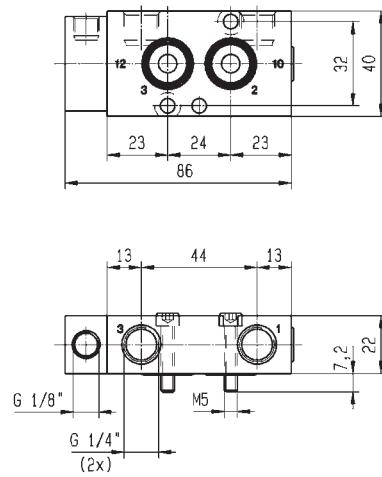

Dimensions Reference 5

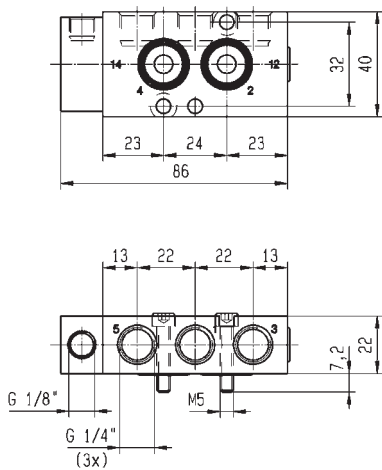

Dimensions Reference 6

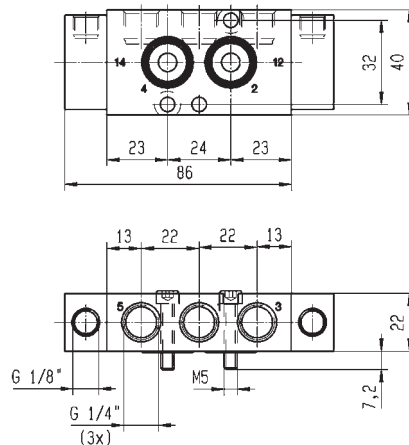

Dimensions Reference 7 & 8

G 1/2" Serie

Port size	Orifice	Q _N	Admissible differential pressure (bar)		Max. admissible fluid temperature (°C)	Seat disc	Reference number		(Watt) consumption Power		(g) Weight	Dimensions Reference
			max.	min.			Valve	Coil	DC	AC		
G	mm	L/min	min	DC= AC~	Air & Neutral gases							

3/2 Pilot operated valve - Internal pressure supply

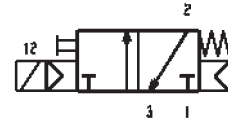

1/2	12	3000	2.5	10	10	50	NBR	331N04	496131	3	3	720	9
-----	----	------	-----	----	----	----	-----	---------------	--------	---	---	-----	---

5/2 Pilot operated valve - Internal pressure supply



1/2	12	3000	2.5	10	10	50	NBR	341N04	496131	3	3	700	10
-----	----	------	-----	----	----	----	-----	---------------	--------	---	---	-----	----

5/2 Control by 2 solenoids and internal pressure supply



1/4	7	1250	2	10	10	50	NBR	347N04	496131	3	3	430	11
-----	---	------	---	----	----	----	-----	---------------	--------	---	---	-----	----

3/2 Externally operated valve - External pressure supply 2.5 to 10 bar

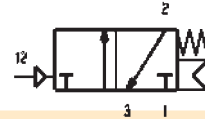

1/2	12	3000	2.5	10	10	50	NBR	531N034	-	-	-	620	12
-----	----	------	-----	----	----	----	-----	----------------	---	---	---	-----	----

5/2 Externally operated valve - External pressure supply 2.5 to 10 bar



1/2	12	3000	2.5	10	10	50	NBR	541N04	-	-	-	600	13
-----	----	------	-----	----	----	----	-----	---------------	---	---	---	-----	----



WARNING - USER RESPONSIBILITY

FAILURE OR IMPROPER SELECTION OR IMPROPER USE OF THE PRODUCTS DESCRIBED HEREIN OR RELATED ITEMS CAN CAUSE DEATH, PERSONAL INJURY AND PROPERTY DAMAGE.

- This document and other information from Parker-Hannifin Corporation, its subsidiaries and authorized distributors provide product or system options for further investigation by users having technical expertise.
- The user, through its own analysis and testing, is solely responsible for making the final selection of the system and components and assuring that all performance, endurance, maintenance, safety and warning requirements of the application are met. The user must analyze all aspects of the application, follow applicable industry standards, and follow the information concerning the product in the current product catalog and in any other materials provided from Parker or its subsidiaries or authorized distributors.
- To the extent that Parker or its subsidiaries or authorized distributors provide component or system options based upon data or specifications provided by the user, the user is responsible for determining that such data and specifications are suitable and sufficient for all applications and reasonably foreseeable uses of the components or systems.

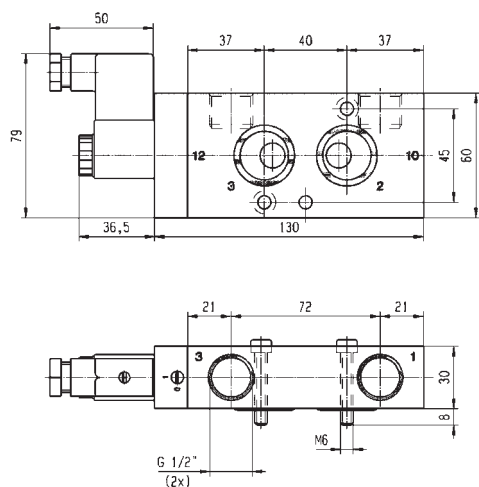

Dimensions Reference 9

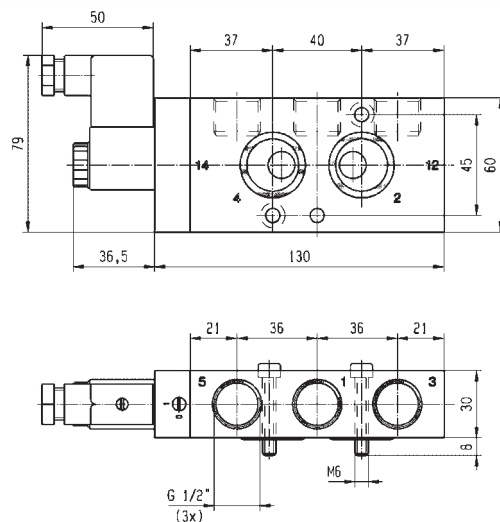

Dimensions Reference 10

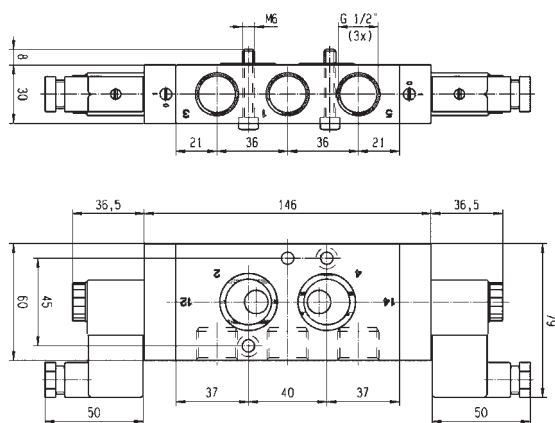

Dimensions Reference 11

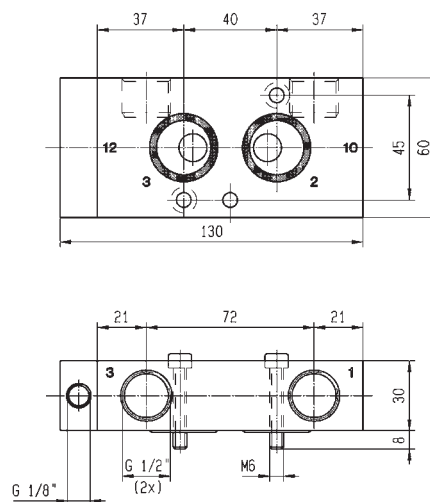

Dimensions Reference 12

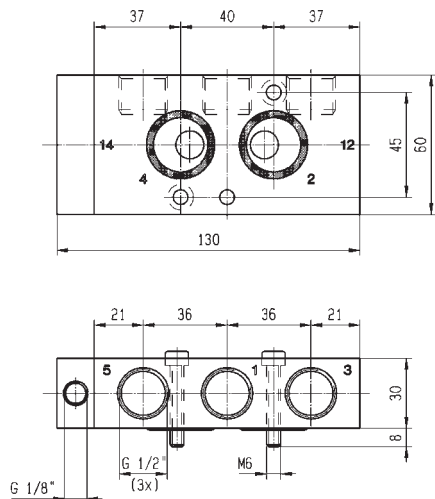

Dimensions Reference 13

Worldwide division headquarters

Parker Lucifer SA

Fluid Control Division Europe
Ch. Fbg-de-Cruseilles, 16
CH - 1227 Carouge / Geneva
Switzerland
Tel. : +41 22 30 77 111
Fax : +41 22 30 77 110
www.parker.com/fcde
infolucifer@parker.com

Parker Hannifin S.p.A.

Via E. Fermi, 5
IT - 20060 Gessate (Milan)
Italy
Tel. : + 39 02 95 125 1
Fax : + 39 02 95 382 051
www.parker.com/fcde
cicgessate@parker.com

Parker Hannifin Corporation

Fluid Control Division
95 Edgewood Ave.
US - New Britain, CT 06051-4100
USA
Tel. : +1 (860) 827 2300
Fax : +1 (860) 827 2384
www.parker.com/fcd
skinnervalue@parker.com

Parker Hannifin Corporation

Fluid Control Division
147 West Hoy Road
US - Madison, MS 39110-9357
USA
Tel. : +1 (601) 856 4123
Fax : +1 (601) 853 7250
www.parker.com/fcd
skinnervalue@parker.com

Parker Korea Ltd.

777 Jungri, Dongtanmyeon,
KR - Hwasungsi, Kyunggido,
445-813 - South Korea
Tel. : (82) 31 379 2200
Fax : (82) 31 377 9710
www.parker.com/fcd



Parker Lucifer SA

Climate & Industrial Controls Group
Fluid Control Division Europe
Ch. Fbg de Cruseilles, 16
1227 Carouge / Geneva
Switzerland
Tel. : +41 22 30 77 111
Fax : +41 22 30 77 110
www.parker.com/fcde
infolucifer@parker.com